



Instructions for Use for
HYDROFLEX



Document Part No. 30086671

2013-08

Document Revision No. 1.4

Firmware Level: 2.x



30086671 00

Tecan Customer Support

If you have any questions or need technical support for your Tecan product, contact your local Tecan Customer Support organization. Go to <http://www.tecan.com/> for contact information.

Prior to contacting Tecan for product support, prepare the following information for the best possible technical support (see name plate):

- Model name of your product
- Serial number (SN) of your product
- Software and software version (if applicable)
- Description of the problem and contact person
- Date and time when the problem occurred
- Steps that you have already taken to correct the problem
- Your contact information (phone number, fax number, e-mail address, etc.)



WARNING
**CAREFULLY READ AND FOLLOW THE INSTRUCTIONS PROVIDED
IN THIS DOCUMENT BEFORE OPERATING THE INSTRUMENT.**

Notice

Every effort has been made to avoid errors in text and diagrams; however, Tecan Austria GmbH assumes no responsibility for any errors that may appear in this publication.

It is the policy of Tecan Austria GmbH to improve products as new techniques and components become available. Tecan Austria GmbH therefore reserves the right to change specifications at any time with appropriate validation, verification, and approvals.

We would appreciate any comments on this publication.



Manufacturer

Tecan Austria GmbH
Untersbergstr. 1A
A-5082 Grödig, Austria
T: +43 6246 8933
F: +43 6246 72 770
www.tecan.com
E-mail: office.austria@tecan.com

Copyright Information

The contents of this document are the property of Tecan Austria GmbH and are not to be copied, reproduced, or transferred to another person or persons without our prior written permission.

Copyright © Tecan Austria GmbH
All rights reserved.
Printed in Austria.

Declaration for EU Certificate

See the last page of these Instructions for Use.

Intended Use of Instrument

See chapter 2.2.1 HYDROFLEX Intended Use.

About the Instructions for Use (IFU)

Original instructions. This document describes the HYDROFLEX, designed to wash microplates.

It contains instruction for the use of the instrument and is intended as a reference for the user. It contains information about the following:





1. Installing the instrument
2. Operating the instrument
3. Programming of wash procedures
4. Defining of wash parameters
5. Cleaning and maintenance procedures

Trademarks

The following product names and any registered or unregistered trademarks mentioned in this document are used for identification purposes only and remain the exclusive property of their respective owners:

- [Product Name]TM (infinite[®])
Tecan[®] and the Tecan Logo are registered trademarks of Tecan Group Ltd., Männedorf, Switzerland
- DNA ExpertTM is a registered trademark of Techcomp Ltd., Hong Kong, China
- Agilent[®] is a registered trademark of Agilent Technologies, Inc., Santa Clara, CA, USA
- AIR LIQUIDETM is a registered trademark of AIR LIQUIDE, S.A., Paris, France
- Aseptisol[®] is a registered trademark of BODE Chemie GmbH & Co. KG, Hamburg, Germany
- Bacillol[®] is a registered trademark of BODE Chemie GmbH & Co. KG, Hamburg, Germany
- Costar[®], Corning[®] and NBSTM are registered trademarks of Corning Incorporated, Corning, NY, USA
- Greiner[®], µClear[®], LumitracTM and FluotracTM are registered trademarks of Greiner Labortechnik GmbH, Frickenhausen, Germany
- HTRF[®] is a registered trademark of Cisbio International, France
- InvitrogenTM is a registered trademark of Invitrogen Corporation, Carlsbad, CA, USA
- Lysetol[®] and Gigasept Intru AF[®] (formerly Lysetol) are registered trademarks of Schülke & Mayr GmbH, Norderstedt, Germany
- Microcide[®] is a registered trademark of Global Biotechnologies Inc., Portland, Maine, USA
- Microman[®] is a registered trademark of Gilson, Inc., Middleton, WI, USA
- Pentium[®] is a registered trademark of Intel Corporation, Santa Clara, CA, USA
- Invitrogen[®] and PanVera[®] are registered trademarks of Invitrogen Corporation Carlsbad, CA, USA
- Windows[®], MS DOS[®], Visual Basic[®] and Excel[®] are registered trademarks of Microsoft Corporation, Redmond, WA, USA
- Hamamatsu[®] is a registered trademark of HAMAMATSU Photonics K.K. [IR], Hamamatsu City, Japan
- NUNCTM and Matrix are registered trademarks of Thermo Fisher Scientific, Waltham, MA, USA
- Polyfiltronics[®] is a registered trademark of Whatman International Ltd.
- Dynex[®] is a registered trademark of Magellan Biosciences, Chelmsford, MA, USA
- Labsystem[®] is a registered trademark of Labsystem kft., Budapest, Hungary
- BRET²[®], DeepBlueC[®] and PerkinElmer[®] are registered trademarks of PerkinElmer, Inc., Waltham, Massachusetts, USA
- Chroma-GloTM is a registered trademark of Promega Corporation, Madison, WI 53711 USA
- MycoAlert[®] is a registered trademark of Cambrex Corporation, East Rutherford, NJ, USA

Symbols

	Manufactured by
	Date of Manufacturing
	Indicates the possible presence of biologically hazardous material.
	Indicates the possible presence of a strong magnetic field.
	Consult the Instructions for Use

Warnings, Cautions and Notes

The following types of notices are used in this publication to highlight important information or to warn the user of a potentially dangerous situation:



Note
Gives helpful information.



Caution
Indicates a possibility of instrument damage or data loss if instructions are not followed.



WARNING
INDICATES THE POSSIBILITY OF SEVERE PERSONAL INJURY, LOSS OF LIFE OR EQUIPMENT DAMAGE IF THE INSTRUCTIONS ARE NOT FOLLOWED.



WARNING
THIS SYMBOL INDICATES THE POSSIBLE PRESENCE OF BIOLOGICALLY HAZARDOUS MATERIAL. PROPER LABORATORY SAFETY PRECAUTIONS MUST BE OBSERVED.

**ATTENTION**

NEGATIVE ENVIRONMENTAL IMPACTS ASSOCIATED WITH THE TREATMENT OF WASTE.

- **DO NOT TREAT ELECTRICAL AND ELECTRONIC EQUIPMENT AS UNSORTED MUNICIPAL WASTE.**
- **COLLECT WASTE ELECTRICAL AND ELECTRONIC EQUIPMENT SEPARATELY.**

**WARNING**

RISK OF FIRE AND EXPLOSION!

ETHANOL IS FLAMMABLE AND WHEN IMPROPERLY HANDLED CAN LEAD TO EXPLOSIONS. PROPER LABORATORY SAFETY PRECAUTIONS MUST BE OBSERVED.

Abbreviations

Abbreviation	
A	Ampere
°C	Degrees Celsius
CE	Conformité Européenne
cm	Centimeter
CV	Coefficient of Variation
ELISA	Enzyme-Linked ImmunoSorbent Assay
EN	European Norm: a voluntary European standard of the European Committee for Standardization or Comité Européen de Normalisation (CEN)
°F	Degrees Fahrenheit
hPa	Hectopascal
Hz	Hertz
IEC	International Electrotechnical Commission
IFU	Instructions for Use
in.	Inch
inHg	Inches of mercury
IVD	In vitro diagnostics
kg	Kilogram
l; L	Liter
m	Meter
mBar	Millibar
ml	Milliliter
mm	Millimeter
mS	Millisiemens
µl	Microliter
PCR	Polymerase Chain Reaction
ppm	Parts per million
QC	Quality Control
REF	Reference number/ Order number
s	Second
SN	Serial number
T	Träge (Slow Blow Fuse)
torr	Torr – millimeter of mercury (mmHg)
TYPE	Name and type of instrument
USB	Universal Serial Bus
V	Volt
VA	Volt ampere
WEEE	Waste electrical and electronic equipment

Table of Contents

1. Safety	11
1.1 Instrument Safety	11
2. General	15
2.1 Introduction	15
2.2 Area of Application	15
2.2.1 <i>HYDROFLEX Intended Use</i>	15
2.2.2 <i>User Profile</i>	16
2.2.3 <i>HYDROFLEX Configurations and Options</i>	16
2.3 Instrument Specifications	17
2.4 Instrument Description	19
2.4.1 <i>Instrument Dimensions</i>	20
2.4.2 <i>Rear Panel Connections</i>	21
2.4.3 <i>Liquid System Diagram</i>	22
2.5 HYDROFLEX Option	22
2.5.1 <i>Liquid Level Detection (LLD)</i>	22
2.5.2 <i>Fitting and Connecting the Liquid Level Detection (LLD)</i> <i>(Optional)</i>	22
2.6 Microplate Requirements	23
3. Installation	25
3.1 Installation Requirements	25
3.1.1 <i>Required Working Area</i>	25
3.1.2 <i>Power Requirements</i>	25
3.2 Unpacking and Inspection	25
3.2.1 <i>Unpacking and Inspection Checklist</i>	26
3.3 Installation Procedure	27
3.3.1 <i>Connection Diagram</i>	28
4. Operating Instructions	29
4.1 Switching the Instrument On	29
4.2 Instrument Firmware	30
4.2.1 <i>Instrument Firmware Menus</i>	30
4.3 Operating Instructions	33
4.3.1 <i>Performing a Wash Procedure</i>	33
4.4 Wash Modes	34
4.5 Washing Positions	34
4.6 Aspirating Modes	35
4.7 Drip Mode	36
4.8 End of Operation	38
4.8.1 <i>Instrument Left Switched On</i>	38

4.8.2	<i>Instrument Switched Off</i>	39
5.	Programming Procedure	41
5.1	Introduction	41
5.2	Program Menu	41
5.2.1	<i>Starting a Program</i>	42
5.2.2	<i>Define/Edit a Program (Define/Edit Menu)</i>	43
5.2.3	<i>Process Step: Aspirate</i>	44
5.2.4	<i>Process Step: Dispense</i>	45
5.2.5	<i>Process Step: Wash</i>	46
5.2.6	<i>Process Step: Soak</i>	47
5.2.7	<i>Process Step: User Prompt</i>	47
5.3	Show Program	48
5.4	Clear Program	49
6.	Settings Menu	51
6.1	Introduction	51
6.1.1	<i>Edit Plates</i>	51
6.1.2	<i>Options Submenu</i>	52
6.1.3	<i>Bubble Sensor</i>	52
6.2	Procedures Menu	53
6.2.1	<i>Rinse</i>	53
6.2.2	<i>Prime</i>	53
6.2.3	<i>Empty Prime Tray</i>	53
7.	Performance Testing/ Quality Control	55
8.	Maintenance and Cleaning	59
8.1	Rinsing	59
8.1.1	<i>Rinse Menu</i>	59
8.2	Priming	62
8.3	Cleaning Procedures	64
8.3.1	<i>Cleaning the Cover and Display</i>	64
8.3.2	<i>Cleaning the Liquid System</i>	64
8.4	Liquid or Foam Spills	66
8.5	Preventive Maintenance Plan	67
8.5.1	<i>Daily</i>	67
8.5.2	<i>Weekly</i>	67
8.5.3	<i>Every Six Months</i>	68
8.5.4	<i>Yearly (Service Engineer Required)</i>	68
8.6	Replacing the Manifold	68
8.6.1	<i>General Description of the Manifold</i>	69
8.6.2	<i>Removing the Manifold</i>	70
8.6.3	<i>Installing the Manifold</i>	71

8.7	Replacing the Plate Carrier.....	73
8.8	Instrument Disinfection.....	74
8.8.1	<i>Disinfection Solutions</i>	74
8.8.2	<i>Disinfection Procedure.....</i>	75
8.9	Disposal of Instrument.....	77
8.9.1	<i>Introduction.....</i>	77
8.9.2	<i>Disposal of Packing Material.....</i>	77
8.9.3	<i>Disposal of Operating Material.....</i>	78
8.9.4	<i>Disposal of the HYDROFLEX.....</i>	78
9.	Trouble Shooting and Error Messages.....	79
9.1	Errors.....	79
9.2	Error Messages.....	79
9.2.1	<i>Standard Instrument: Error Messages.....</i>	79
9.2.2	<i>Liquid Level Detection: Error Messages</i>	81
Index	83	

1. Safety

1.1 Instrument Safety

1. Always follow basic safety precautions when using this product to reduce the risk of injury, fire, or electrical shock.
2. Read and understand all information in the IFU. Failure to read, understand, and follow the instructions may result in damage to the product, injury to operating personnel or poor instrument performance.
3. Observe all Warning and Caution notices in the IFU (see Warnings, Cautions and Notes on page 4 for a description of the notices used in this document).
4. Never open the HYDROFLEX while the instrument is plugged into a power source.
5. Observe proper laboratory safety precautions, such as wearing protective clothing and using approved laboratory safety procedures.



Note

Suitable Compact Microplates

The HYDROFLEX supports the processing of flat, round, or v-shaped bottom microplates in 96-well format typically used for EIA, which conform to the standard defined by the Society of Biomolecular Screening. Other plate types in 96-well format such as deep-well plates and PCR-plates cannot be used with the HYDROFLEX.



Caution

Be careful when using strip plates that the strips are positioned in the microplate as defined in the program used for plate washing, otherwise spilling can occur and the instrument may become contaminated (see 4.4 Wash Modes and 5.2.2 Define/Edit a Program (Define/Edit Menu)).



Note

Suitable Strip Plates

To achieve proper wash-performance with strip plates ensure that:

- *All strips have been properly inserted into the frame of the strip-plate to give a level surface;*
- *The number of strips used, matches the type of manifold used (8-way manifold: use minimum of one strip, 16-way manifold: use minimum of two strips);*
- *The current position of the strips within a strip plate matches the position of the strips as defined in program used for plate washing. See chapter 5.2.2 Define/Edit a Program (Define/Edit Menu).*

**WARNING**

TO ENSURE PROPER WASH PERFORMANCE IT IS MANDATORY TO ADJUST THE HYDROFLEX TO THE TYPE / MANUFACTURER OF MICROPLATE OR STRIP-PLATE USED. THIS ALSO APPLIES FOR ANY PRE-DEFINED PLATE FILE, THAT WILL ALWAYS CONTAIN AVERAGE PLATE PARAMETERS ONLY, THAT HAVE TO BE VERIFIED WITH THE CORRESPONDING PLATE TYPE AND IF NECESSARY CORRECTED BEFORE PUTTING THE HYDROFLEX INTO USE.

IF THIS ADJUSTMENT PROCEDURE IS NOT PERFORMED PROPERLY, THIS MIGHT RESULT IN HIGH LEVELS OF RESIDUAL VOLUME PER WELL, AS WELL AS INSUFFICIENT WASHING OF THE WELLS AND MAY SERIOUSLY AFFECT ASSAY PERFORMANCE. FOR DETAILS ON HOW TO ADJUST THE HYDROFLEX TO THE TYPE OF MICROPLATE OR STRIP-PLATE USED, SEE CHAPTER 6 SETTINGS MENU IN THIS MANUAL.

**WARNING****WASTE BOTTLE – LIQUID LEVEL**

MAKE SURE THAT THE LIQUID LEVEL OF THE WASTE BOTTLE IS ALWAYS KEPT BELOW THE MAXIMUM LEVEL INDICATED ON THE BOTTLE TO AVOID POTENTIAL OVERFLOW. AS THE CONTENTS OF THE WASTE BOTTLE ARE POTENTIALLY INFECTIOUS; WEAR PROTECTIVE CLOTHING (GLOVES, LAB COAT AND SAFETY GLASSES) WHEN EMPTYING / HANDLING A WASTE BOTTLE (SEE 8.3.2 CLEANING THE LIQUID SYSTEM).

INQUIRE ABOUT APPROPRIATE COLLECTING POINTS AND APPROVED METHODS OF DISPOSAL IN YOUR COUNTRY, STATE OR REGION.

**WARNING**

THE INSTRUMENT COMPLIES WITH THE EMISSION AND IMMUNITY REQUIREMENTS DESCRIBED IN IEC 61326-2-6; HOWEVER, THE ELECTROMAGNETIC ENVIRONMENT SHOULD BE EVALUATED PRIOR TO THE OPERATION OF THE INSTRUMENT.

IT IS THE OPERATOR'S RESPONSIBILITY TO ENSURE THAT A COMPATIBLE ELECTROMAGNETIC ENVIRONMENT FOR THE INSTRUMENT IS MAINTAINED, SO THAT THE INSTRUMENT PERFORMS AS INTENDED.

DO NOT OPERATE THE INSTRUMENT IN CLOSE PROXIMITY TO SOURCES OF STRONG ELECTROMAGNETIC RADIATION (E.G. UNSHIELDED INTENTIONAL RF SOURCES) AS THIS MAY INTERFERE WITH THE PROPER FUNCTION OF THE INSTRUMENT AND MAY ALSO LEAD TO INCORRECT RESULTS.

**WARNING**

WHEN USING WASH BUFFERS THAT SHOW A STRONG TENDENCY OF FOAMING, EMPTY THE WASTE BOTTLE AS SOON AS THE FOAM-LEVEL HAS REACHED THE MAXIMUM FILLING LEVEL INDICATED ON THE WASTE BOTTLE. ADDITIONALLY, ADD A COMMERCIALY AVAILABLE ANTI-FOAMING AGENT (SUCH AS SILICONE OIL) TO THE EMPTY WASTE BOTTLE TO REDUCE FOAMING.

IF FOAMING CONTINUES TO BE A PROBLEM, WE RECOMMEND SWITCHING TO A LARGER WASTE BOTTLE (NOT PROVIDED WITH THE HYDROFLEX) AND ADDITIONALLY INCREASE THE CONCENTRATION OF ANTI-FOAMING AGENT IN THE WASTE BOTTLE. TO HELP FACILITATE BREAKDOWN OF THE FOAM IN THE WASTE BOTTLE, CAREFULLY SWIRL THE WASTE BOTTLE FROM TIME-TO-TIME TO IMPROVE MIXING BETWEEN FOAM LAYER AND ANTI-FOAMING AGENT.

REFILL ANTI-FOAMING AGENT AFTER EMPTYING WASTE BOTTLE. FOR EXAMPLE, WHEN USING THE WACKER ANTI-FOAM EMULSION SE47 (WACKER ARTICLE CODE 21640582), THE RECOMMENDED CONCENTRATION IS 1ML OF ANTIFOAMING AGENT FOR 1 LITER OF WASTE SOLUTION.

FOR ANTIFOAMING AGENTS FROM OTHER MANUFACTURERS, USE CONCENTRATIONS AS RECOMMENDED BY CORRESPONDING MANUFACTURERS.

2. General

2.1 Introduction

The HYDROFLEX is an instrument for strip-wise processing of microplates in the 96-well format. The instrument is designed for professional use only and should only be operated by trained personnel.



Caution

The wash results obtained with the HYDROFLEX are influenced by the correct use of the instrument, according to the instructions given in this IFU, as well as the liquid compounds used (reagents, wash buffer, chemical components). The instructions for use, storage, and other handling in connection with samples or reagents must be strictly followed. Taking these facts into consideration, results must be interpreted carefully.



Caution

Before the instrument is installed and switched on it should be left to stand for at least three hours, so there is no possibility of condensation causing a short circuit.



Caution

Before washing procedures are started, make sure that the microplate position A1 is inserted correctly.

2.2 Area of Application

2.2.1 HYDROFLEX Intended Use

The HYDROFLEX is a plate washer for 96-well microplates.

The instrument is intended to be used primarily in in-vitro diagnostic processing of samples from the human body to obtain information on physiological and pathological states.

Software and instrument have been validated for processing of qualitative and quantitative Enzyme-linked Immunosorbent Assays (ELISA) and therefore are intended for professional use in in-vitro diagnostics.

The instrument has not been validated for other areas of application not mentioned in the Intended Use (e.g. veterinary, biopharma).



Caution

MANDATORY SYSTEM VALIDATION BY OPERATING AUTHORITY

It is the responsibility of any Operating Authority to ensure that the HYDROFLEX has been validated according to applicable regulations for each specific assay used on the instrument.

2. General

2.2.2 User Profile

Professional User - Administrator Level

The administrator is a person who has suitable technical training and corresponding skills and experiences. If the product is used as intended, the person is able to recognize and avoid dangers.

The administrator has extensive skills and is able to instruct the end user or the routine user in assay protocols in connection with a Tecan product within the bounds of the intended use.

Computer application skills and good English skills are required.

End User or Routine User

The end user or routine user is a person who has suitable technical training and corresponding skills and experiences. If the product is used as intended, the person is able to recognize and avoid dangers.

Computer application skills and good language skills for the respective national language at the installation site and English are required.

Service Technician

The service technician is a person who has suitable technical training and corresponding skills and experiences. If the product needs to be serviced or maintained, the person is able to recognize and avoid dangers.

Computer application skills and good English skills are required.



Note

Training dates, their duration and frequency are available at your customer support.

Address and phone number can be found in the instructions for use and in the web: <http://www.tecan.com/customer-support>

2.2.3 HYDROFLEX Configurations and Options

The following instrument configurations and options are available for the HYDROFLEX:

HYDROFLEX configurations include:

- HYDROFLEX with 8-way manifold and 1, 2 or 4 inlet channels
- HYDROFLEX with 16-way manifold and 1, 2 or 4 inlet channels

Option for factory-installation on HYDROFLEX models include:

- Liquid Level Detection (LLD) – online monitoring of the liquid level of the liquid and waste bottles.



Caution

Unauthorized modification of the HYDROFLEX, any of its options and/or components as well as on any corresponding software or spare parts will result in a loss of warranty and a potential loss in instrument performance.



Caution

It is important to understand that the proper installation of the instrument and HydroControl software alone will not ensure compliance with national, regional or local regulations. A range of policies and standard operating procedures according to applicable regulations must additionally be established.

2.3 Instrument Specifications



Note
Instrument specifications have been defined using Greiner flat-bottom compact 96-well microplates and may vary using other 96-well plates or 96-well strip-plates.

The table below lists the specifications for the instrument. All specifications listed below are based on the following instrument settings:

Dispense/Wash rate: 250 µl/s
 Aspiration rate: 3

PARAMETERS	CHARACTERISTICS
General	
Display unit	Liquid Crystal Display with two rows of sixteen digits
Keyboard	Four key membrane keyboard
Number of dispensing channels	Up to four channels
Manifold types	8 and 16-way manifold
USB Interface	All connected devices must be approved and listed as per IEC 60950-1 Information Technology Equipment – Safety or equivalent local standards.
Variable	
Volume of solution dispensed	50 - 3000 µl in 50 µl increments for washing 50 - 400 µl in 50 µl increments for dispensing
Dispensing accuracy	<= 2 % Measured under following conditions: 8-way manifold, 300 µl, dispensing rate 3 (250 µl/s/well), wash buffer, Greiner 96 well flat bottom plate
Dispensing uniformity	<= 4 % CV Measured under following conditions: 8-way manifold, 300 µl, dispensing rate 3 (250 µl/s/well), wash buffer, Greiner 96 well flat bottom plate
Residual volume	Measured under following conditions: <= 2 µl / well (Greiner 96-well flat bottom plate) <ul style="list-style-type: none"> • Crosswise aspiration, 8-way manifold, aspiration rate: 3, aspiration time: 4 s, head speed: 10 mm/s, wash buffer. • Residual volume of <= 2 µl / well cannot be guaranteed if a 16-way manifold is used and if not all wells are filled with liquid.
	<= 5 µl / well (Greiner 96-well round bottom and V-shaped bottom plates) <ul style="list-style-type: none"> • Single aspiration, 8-way manifold, aspiration rate: 3, aspiration time: 4 s, head speed: 10 mm/s, wash buffer. • Residual volume of <= 5 µl / well cannot be guaranteed if a 16-way manifold is used and if not all wells are filled with liquid.

2. General

PARAMETERS	CHARACTERISTICS
Carry over between wells	<p>≤ 1 ppm</p> <p>The Carry over between wells ≤ 1 ppm cannot be guaranteed if not all wells are filled with liquid.</p>
Power	
Supply	<p>Auto-sensing</p> <p>100 - 120 V or 220 - 240 V, 50/60 Hz</p>
Consumption	< 65 VA
Physical	
Outside dimensions	<p>Width: 275 mm, Depth: 366 mm, Height: 180.5 mm (Width: 10.8 inches, Depth: 14.4 inches, Height: 7.1 inches)</p>
Weight	6.6 kg
Environmental	
Ambient temperature	
Operation	15°C to 35°C (59°F to 95°F)
Storage	-20°C to 60°C (-4°F to 140°F)
Relative Humidity	
Operation	20 % to 80 % non condensing
Storage	10 % to 80 % non condensing
Others	
Overvoltage category	II
Pollution degree	2
Method of disposal	Electronic waste (infectious waste)

2.4 Instrument Description

The diagram below shows the main components of the instrument:

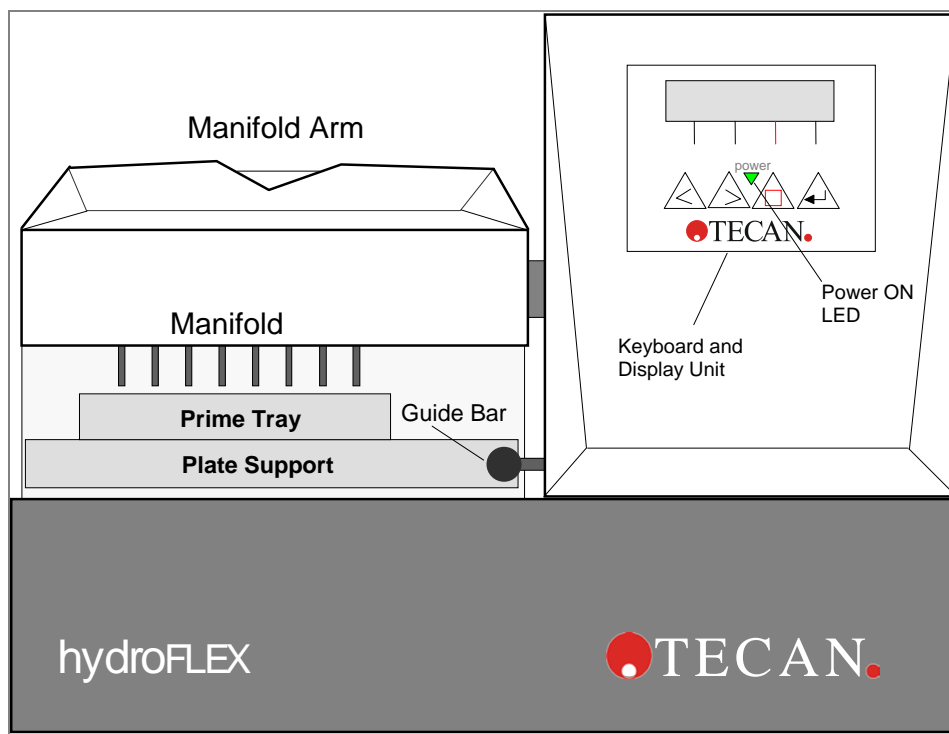

2. General

2.4.1 Instrument Dimensions

Standard Instrument – Dimensions

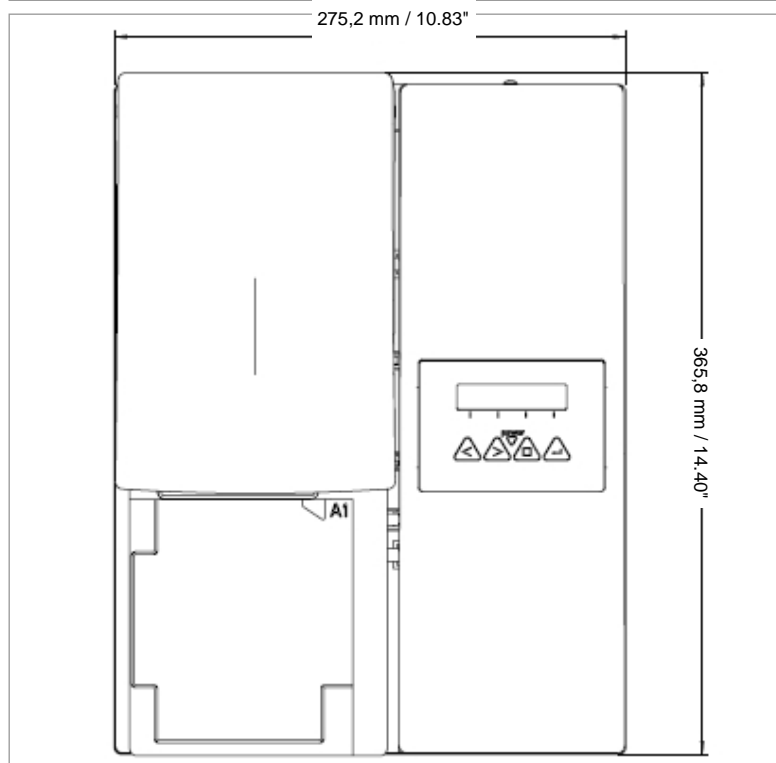
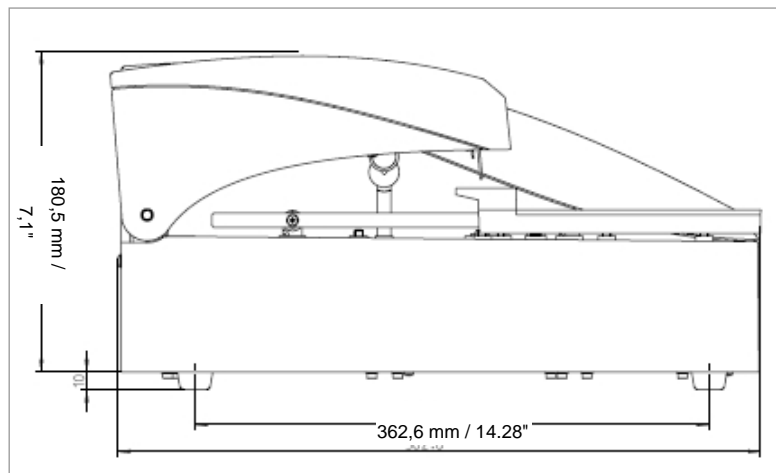
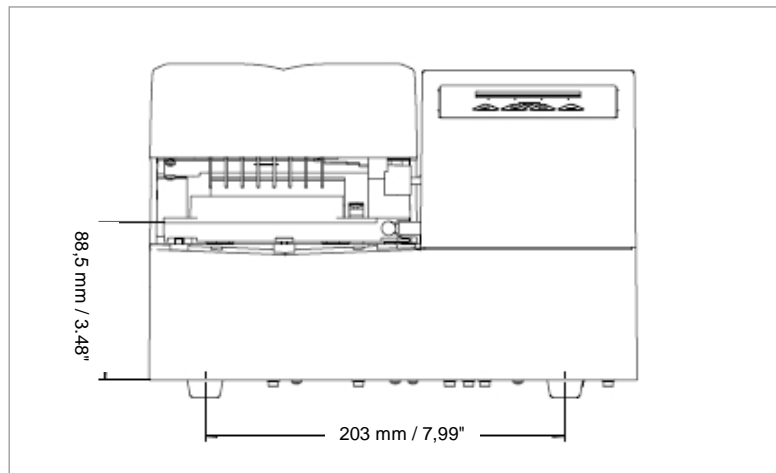

2.4.2 Rear Panel Connections

The instrument has the following connections on the rear panel:

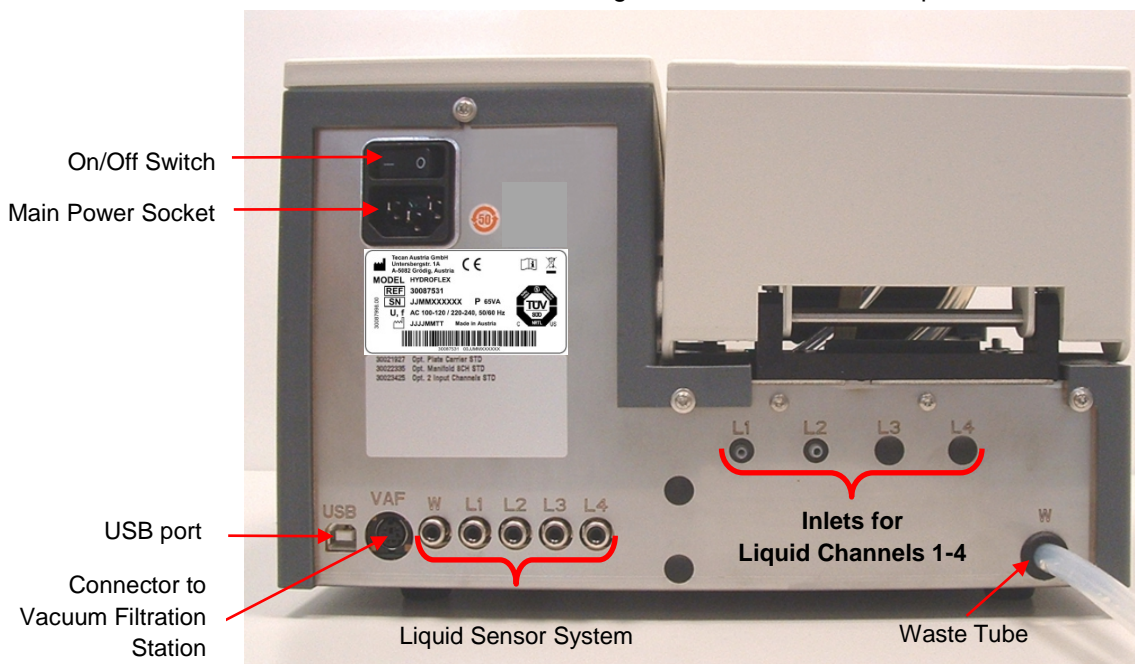

HYDROFLEX Name Plate

Example name plate



Contents of the name plate (e.g. model name and article number) may vary depending on the specific model.

For an overview of the various instruments for which these Instructions for Use are valid, see the Declaration of Conformity on the last page of this document.

All connected devices must be approved and listed as per IEC 60950-1 Information Technology Equipment – Safety or equivalent local standards.

2. General

2.4.3 Liquid System Diagram

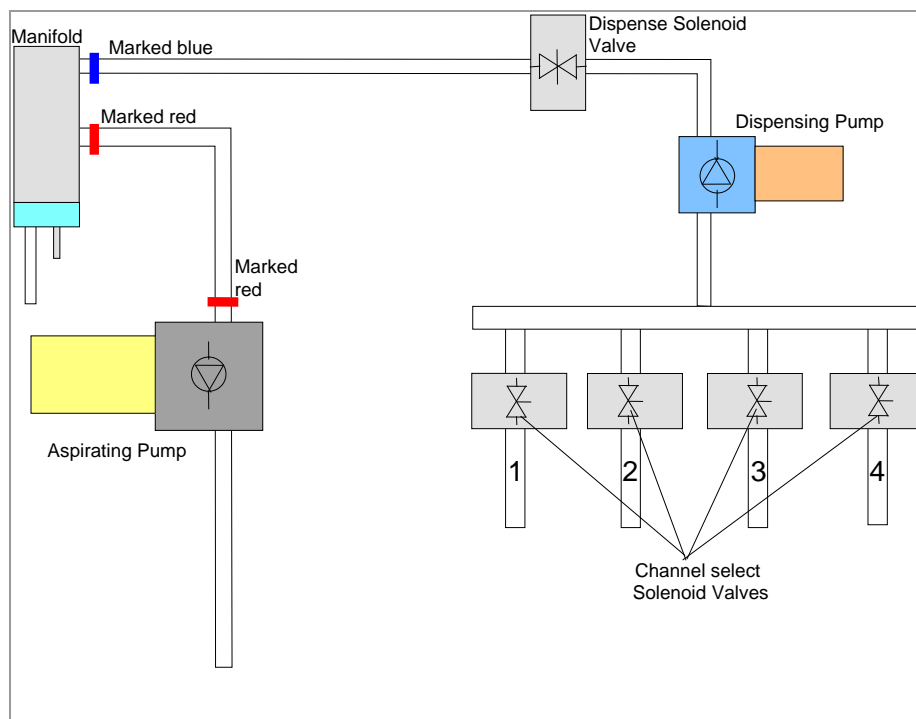

2.5 HYDROFLEX Option

The HYDROFLEX can be delivered with the following option:

Liquid Level Detection (LLD)

The level of the liquid and the waste bottles is checked. An acoustic signal alerts the user when the bottles are empty or full.

2.5.1 Liquid Level Detection (LLD)

Liquid level sensors are built into the covers of all bottles to avoid overflow of waste bottles and to warn the user when the liquid bottles are almost empty.

2.5.2 Fitting and Connecting the Liquid Level Detection (LLD) (Optional)

Connect the liquid sensor cables into the appropriate sockets in the rear panel of the instrument. The Liquid Level Detection system can be extended to control up to four different liquid bottles and one waste bottle.



Fig. 2.1 Waste and Liquid Bottles with LLD Sensors

See chapter 3.3.1 Connection Diagram for further details.

2.6 Microplate Requirements

Only 96-well format microplates (round, v-shaped, and flat bottom - including strip plates) can be used with the HYDROFLEX.

PARAMETERS	CHARACTERISTICS
Max. overall plate height	14.35 mm \pm 0.76 mm (0.5650 inches \pm 0.0299 inches)
Footprint	9.0 mm (0.3543 inches)
Pitch size (center to center)	9.0 mm (0.3543 inches)
Bottom shape	Round, v-shaped, and flat

3. Installation

When installing, moving, or connecting the instrument, follow the instructions in this publication. Tecan does not accept the responsibility for injury suffered by anyone attempting these operations without following the instructions in this publication, nor for damage incurred to the instrument.

Make sure the laboratory meets all the requirements and conditions described in this chapter.

3.1 Installation Requirements

3.1.1 Required Working Area

Select a location to place the instrument that is flat, level, vibration free, away from direct sunlight, and free from dust, solvents and acid vapors.

Allow at least 10 cm (4 inches) between the instrument and the wall or any other equipment. Do not place any items close to the instrument that could obstruct airflow.

The liquid bottles should be positioned at the same height as the instrument. If the liquid bottles are placed above or below the instrument (maximum height difference of 1 meter is allowed), the dispensing pump must be recalibrated by a service technician.

For information regarding outer dimensions and weight of the instrument, see chapter 2.3 Instrument Specifications.

3.1.2 Power Requirements

The instrument is designed to operate at either 100 - 120 V or 220 - 240 V.

No voltage setting is required as the instrument automatically senses the supplied voltage. See 2.3 Instrument Specifications for further information.

Connect the instrument only to an electricity supply system with protective earth.

3.2 Unpacking and Inspection

1. Visually inspect the container(s) for damage before opening.
Report any damage immediately.
2. Place the carton in an upright position and open it.
3. Lift the instrument out of the carton and place it in the selected location.
4. Remove the transport protection from the instrument and manifold.
5. Visually inspect the instrument for loose, bent or broken parts.
Report any damage immediately.
6. Compare the serial number on the rear panel of the instrument with the serial number on the packing slip.
Report any discrepancy immediately.
7. Check the instrument accessories against the packing list.
8. Save packing materials for further transportation purposes. The HYDROFLEX must be shipped in the original packaging.

3. Installation

3.2.1 Unpacking and Inspection Checklist

The standard HYDROFLEX is shipped in one carton, which contains:

Carton 1:	<ul style="list-style-type: none"> • Instrument • Accessory package which contains: <ul style="list-style-type: none"> - 6 Manifold screws and Allen key - Main power cable - 2 Cleaning needles - (1, 2 or 4) Solution tube(s) (1m) depending on instrument configuration - USB cable • Bottle set containing: <ul style="list-style-type: none"> - (1, 2 or 4) Liquid bottle(s) (2.5 liter) depending on instrument configuration - 1 Waste bottle (5 liter) • HydroControl software CD • Instructions for Use for HydroControl software • Instructions for Use for HYDROFLEX (this document)
------------------	--

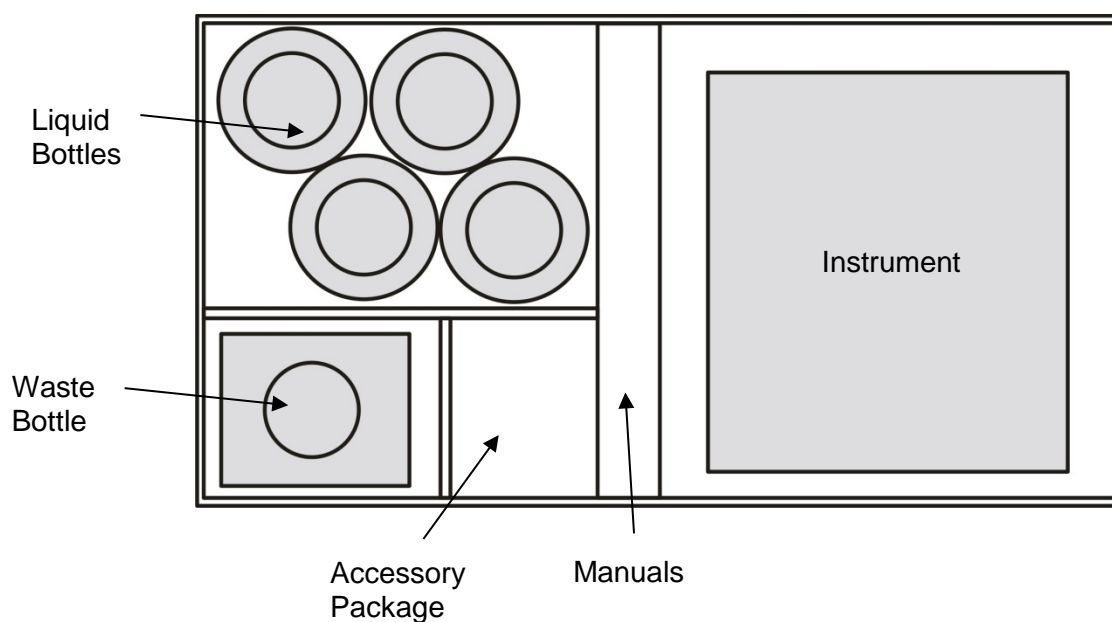

Fig. 3.1 The packaging for HYDROFLEX

3.3 Installation Procedure

After the instrument has been unpacked and the contents of the transport container have been checked for damages and completeness (see 3.2 Unpacking and Inspection), the instrument can be installed using the following procedure:



Caution

Before the instrument is installed and switched on, it should be left to stand for at least three hours, so there is no possibility of condensation causing a short circuit.



Caution

If the liquid bottles are attached improperly or to the wrong connector on the back panel of the instrument, the wash performance can be seriously affected.

- Connect the solution tubes (L1 – L4) to the inlet connectors on the rear panel of the instrument (see 3.3.1 Connection Diagram). The instrument is supplied with one, two, or four 1-meter lengths of tubing (depending on instrument configuration). Connect the solution tubes to the corresponding liquid bottles. Connect the waste tube to the waste bottle (be aware of not kinking the tube!).
- Connect the Liquid Level Sensors, if available.
- Setup instrument options, if available.
- Ensure that the on/off switch in the rear panel of the instrument is in the off position, then connect the instrument to the power supply: insert the main power cable into the main power socket on the rear of the instrument.

3. Installation

3.3.1 Connection Diagram

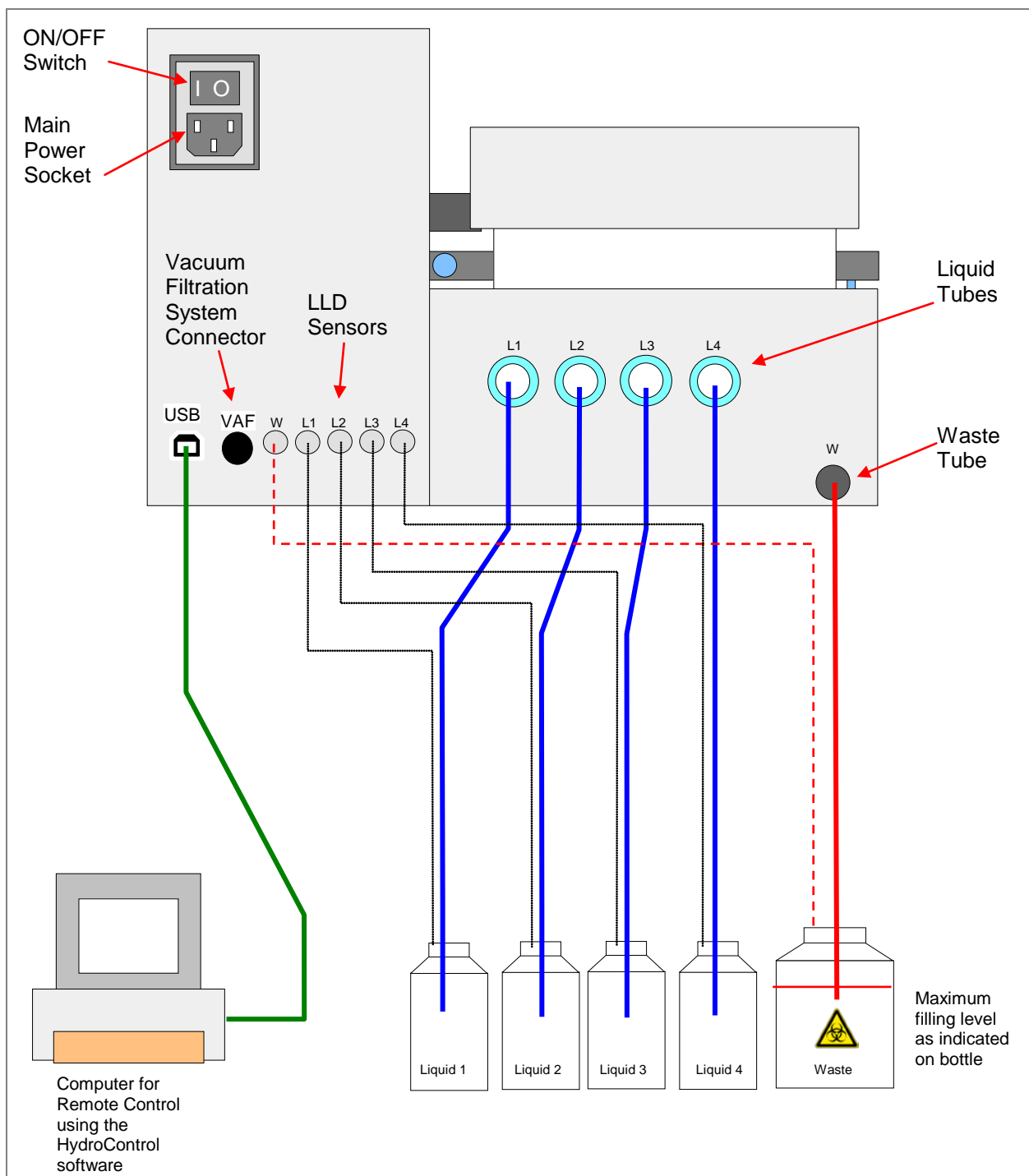

Fig. 3.2 Connection Diagram

4. Operating Instructions

4.1 Switching the Instrument On

Ensure the instrument has been correctly installed and the main power cable is connected into the main power socket in the rear panel of the instrument and the liquid tubes are connected to the correct liquid and waste bottle(s).

Switch ON the instrument, using the on/off switch in the rear panel of the instrument. The initialization procedure is performed and, depending on the instrument type, the following initialization message is displayed:

```
TECAN AUSTRIA
HYDROFLEX
```

“HYDROFLEX” is the name of the instrument, which can be defined via the HydroControl software.

If a **Rinse** procedure was aborted before the instrument was switched off, the following message is displayed after the instrument initializes:

```
PLEASE RINSE
          OK
```

Press **OK** and then select a **Rinse** procedure (see chapter 8.1 Rinsing). After the rinsing procedure has been performed, the instrument proceeds to the standby mode and the following message is displayed:

```
PROGRAM
< > OK
```



Caution

The liquid system must be primed with the liquid that will be used (wash buffer) before it can be used. Please ensure that the dispensing and aspiration pumps are not run for longer than a few minutes without liquid, otherwise they will be damaged.



Caution

At the end of each working day, perform the Rinse Night procedure with distilled water to ensure the proper performance of the HYDROFLEX and to prevent needles from becoming blocked, for details see chapter Rinse Night on page 61.

4.2 Instrument Firmware

The instrument firmware can be used to run and manage wash programs, define plate parameters, adjust certain instrument settings, and perform instrument procedures (rinse, prime and empty prime tray).

Following features are available:

- 20 user definable washing programs, stored under program positions 1 to 20.
- Up to 60 processing steps per program, each processing step can be identical or different from the previous step.
- Adjustable soak time (5 seconds to 60 minutes and 59 seconds).
- Shaking: The following shaking settings are available:
 - High: Linear shaking with a shaking frequency of 25 Hz and a shaking amplitude of 1 mm
 - Medium: Linear shaking with a shaking frequency of 10 Hz and a shaking amplitude of 2 mm
 - Low: Linear shaking with a shaking frequency of 5 Hz and a shaking amplitude of 3 mm
- Adjustable dispense rate (Drip Mode to 500 µl/s)
- Adjustable aspirating speed (1 to 3)
- Adjustable bottom positions (Bottom, Custom, Overflow)
- Two rinse modes (Rinse Day and Rinse Night) can be used to select how the instrument is rinsed before it is left to stand or switched off.
- Automatic microplate centering: the microplate is automatically centered before starting any wash program.
- Programmable strip selection: the strips to be washed can be defined in the program before starting the washing procedure.

4.2.1 Instrument Firmware Menus

The instrument has the following menu options:

Program	Start, Define/Edit, Show, Clear
Settings	Edit Plates, Options, Bubble Sensor
Procedures	Prime, Rinse, Empty Prime Tray

Firmware Commands on the Display (in alphabetical order)

DISPLAY	Meaning...
ASP.RATE #	Aspiration rate #
ASPIRATE	Aspirate
BOTTOM POS.	Bottom position
BUBBLE ERROR	Bubble error
BUBBLE HIGH	Bubble high
BUBBLE LOW	Bubble low
BUBBLE MEDIUM	Bubble medium
BUBBLE OFF	Bubble OFF
BUBBLE SENSOR	Bubble sensor
BURN IN TEST	Burn in test
C# CYCLE	C# Cycle
C# CYCLEEND	C# Cycle End
C# P# ASP	C# P# Aspirate
C# P# CYCLE	C# P# Cycle
C# P# CYCLEEND	C# P# Cycle end
C# P# DISP	C# P# Dispense
C# P# SOAK	C# P# Soak
C# P# USER PR.	C# P# User Prompt
C# P# WASH	C# P# Wash
CH# PRIMED?	Channel# primed?
CHANNEL #	Channel #
CLEAN NO	No cleaning
CLEAN YES	Cleaning
CLEAR	Clear
CLEAR: #	Clear: #
CLR	Clear
CLR CHANNEL 1	Clear channel 1
CLR CHANNEL 2	Clear channel 2
CLR CHANNEL 3	Clear channel 3
CLR CHANNEL 4	Clear channel 4
CLR VAC.WASTE	Clear vacuum waste
CLR WASTE 1	Clear waste 1
Crossw.Asp NO	Crosswise Aspiration no
Crossw.Asp YES	Crosswise Aspiration yes
CYCLE NO #	Cycle number #

DISPLAY	Meaning...
CYCLE NO #	Cycle number #
DEFINE EDIT	Define Edit
DISPENSE	Dispense
DISPENSE POS.	Dispense position
EDIT LLD CHANNEL	Edit LLD channel
EDIT PLATES	Edit plates
EMPTY BOTTLES	Empty bottles
EMPTY PRIMETRAY	Empty prime tray
FINAL ASP?	Final aspiration?
FINAL ASPIRATE	Final aspiration
FL.RATE # ul/s	Flow rate # ul/s
FL.RATE DRIP	Flow rate Drip
H-SPEED # mm/s	Head speed: # mm/s
HYDROFLEX	HYDROFLEX
INIT	Initialize
INIT ERROR	Initialization error
INV CMD	Invalid command
INV PARAMETER	Invalid parameter
LIQUID BOTTLE OK	Liquid bottle OK
LLD ERROR	LLD Error
LLD OFF	LLD OFF
LLD ON	LLD ON
LOCKED	locked
MANIFOLD BROKEN	Manifold broken
MANIFOLD DETECT	Manifold detection
MANIFOLD UP	Manifold up
MISS. PARAMETER	Missing parameter
MOVE CUSTOM	Move custom
MOVE MANIFOLD	Move manifold
MOVE OVERFLOW	Move overflow
MOVE TRANSPORT	Move transport
NAME:	Name:
NO PLATE	No plate
NO PLATE FOUND	No plate found
NO PROGRAM	No Program

4. Operating Instructions

DISPLAY	Meaning...
NO PROGRAM FOUND	No program found
NO.OF CYCLES #	Number of cycles #
NOT DEF	Not defined
OPTIONS	Options
OVERFLOW POS.	Overflow position
PARAMETER RANGE	Parameter range
PLATE	plate
Plate #	Plate #
PLATE INSERTED?	Plate inserted?
PLATE MODE	Plate mode
PLEASE EMPTY	Please empty
PLEASE INSERT	Please insert
PLEASE RINSE	Please rinse
POS. ASP1	Position Aspirate 1
POS. ASP2	Position Aspirate 2
POWERFAILURE	Power failure
PRIME	Prime
PRIME EXIT YES	Prime Exit Yes
PRIME SOL. OK?	Prime solution OK?
PROCEDURES	Procedures
PROGR # DELETED	Program # deleted
PROGR #:	Program #:
PROGRAM	Program
PROGRAM END?	Program End?
PROGRAM IS	Program is
REMOTE	Remote
REMOVE PLATE	Remove Plate
RINSE	Rinse
RINSE DAY	Rinse day
RINSE NIGHT	Rinse night
RINSE SOL. OK?	Rinse solution OK?
RS485 TIMEOUT	RS485 Timeout
RUN #	Run #
SENSOR DEFECT	Sensor defect
SET CHANNEL 1	Set channel 1
SET CHANNEL 2	Set channel 2

DISPLAY	Meaning...
SET CHANNEL 3	Set channel 3
SET CHANNEL 4	Set channel 4
SET VAC.WASTE	Set vacuum waste
SET WASTE 1	Set waste 1
SETTINGS	Settings
SHAKE HIGH	Shake high
SHAKE LOW	Shake low
SHAKE MEDIUM	Shake medium
SHAKE OFF	Shake off
SHAKE YES	Shake yes
SHOW	Show
SOAK	Soak
START	Start
STEPLOSS	Steploss
STRIP MODE	Strip mode
TECAN AUSTRIA	Tecan Austria
TIME	Time
TIME: # s	Time: # s
TIME: #min #s	Time: #min #s
USE OTHER NAME	Use other name
USER PROMPT	User prompt
VACUUM FILTR.	Vacuum filtration
VOLUME	Volume
VOLUME # ul	Volume # ul
WASH	Wash
WASTE BOTTLE OK?	Waste bottle OK?
WASTEBOTTLE	Wastebottle
Y-User Def #	Y-User Defined #
Z-POS: BOTTOM	Z-POS: Bottom
Z-POS: CELL	Z-POS: Cell
Z-POS: CUSTOM	Z-POS: Custom
Z-POS: OVERFLOW	Z-POS: Overflow
Z-POS:MOVE CUST.	Z-POS: Move customer
Z-POS:MOVE OVER.	Z-POS: Move overflow
Z-User Def #	Z-User Defined #

4.3 Operating Instructions

4.3.1 Performing a Wash Procedure

Insert the 96-well microplate to be washed into the plate transport and ensure that the microplate is correctly oriented (position A1 of the plate corresponds to position A1 marked on the plate transport).

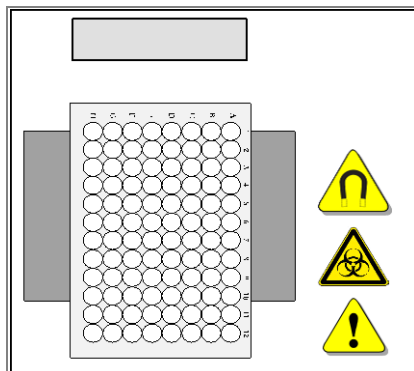

Fig. 4.1 Fitting a microplate

The operating procedure is dependent on the instrument options and the program settings.



Caution

Before washing procedures are started, make sure that the microplate position A1 is inserted correctly.



Caution

Be careful when using strip-plates that the strips are positioned in the microplate as selected in the program, otherwise spilling can occur and the instrument may become contaminated (see 5.2.2 Define/Edit a Program (Define/Edit Menu)).



WARNING

WHEN THE INSTRUMENT IS BUSY, DO NOT TOUCH THE MANIFOLD!

AFTER THE INSTRUMENT HAS BEEN USED, THE MANIFOLD AND PRIME TRAY MAY BE INFECTIOUS!

4. Operating Instructions

4.4 Wash Modes

The instrument can wash a microplate using the following wash modes:

Plate Mode	Each program step is performed on all of the selected strips of a microplate sequentially, before proceeding to the next step. The entire plate or the defined plate range is processed for the defined soaking time.
Strip Mode	The entire wash program is performed on one strip or two consecutive strips of a microplate before proceeding to the next strip(s) (1 strip for 8-way manifold or two strips for 16-way manifold). The strip or group of two strips is processed for the defined soaking time, before proceeding to the next strip or group of strips.

4.5 Washing Positions

Wash, Dispense, and Aspirate steps can be defined in a wash program with the following Z-positions:

Overflow	For ELISA assays and Cellular assays. Overflow washing consists of a simultaneous aspiration and dispense step. It creates a circular flow of wash buffer in the well and ensures that the topmost parts of the well are also washed.
Bottom	For ELISA assays.
Custom	Any necessary washing position can be selected; the custom positions are not saved as *.pdf files in comparison to the overflow and bottom position.
Move Overflow	If Move Overflow (MOVE OVER.) is selected, the manifold moves step-wise from the bottom position to the Overflow position during dispensing. It is recommended for cell wash applications or any applications which must be treated with care.
Move Custom	If Move Custom (MOVE CUST.) is selected, the manifold moves step-wise from the bottom position to the user-defined Custom Z- position during dispensing. It is recommended for cell wash applications or any applications which must be treated with care.

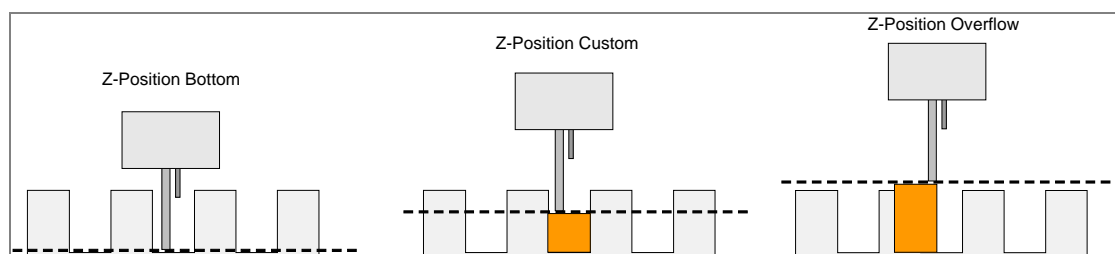

Figure 4.2 Wash Position Diagrams

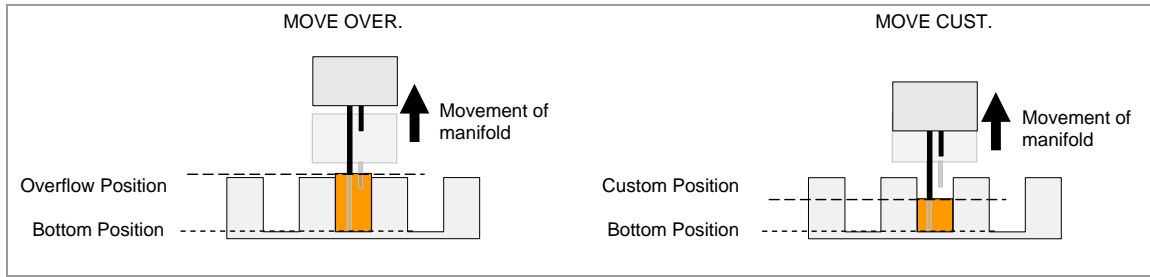

Figure 4.3 Movement Diagrams for Z-positions with MOVE

4.6 Aspirating Modes

To improve wash efficiency and to reduce the residual volume, the manifold must be positioned so that the aspirating needles are correctly positioned in the wells for round-bottom, v-shaped bottom, or flat-bottom well microplates.

Normal Aspiration Mode

For round-bottom or v-shaped bottom wells, the aspirating needles are placed in the middle of the wells. Only one aspiration position can be selected.

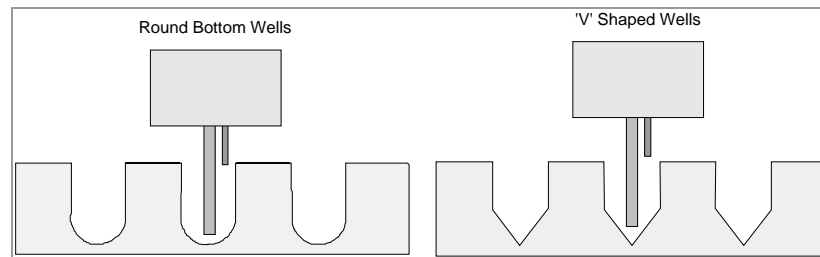

Fig. 4.4 Normal Aspirating Positions

Crosswise Aspiration Mode

With flat bottom wells, the instrument can perform crosswise aspiration using two aspiration positions per well.

The aspirating needles are set at two positions on the bottom of the wells (front edge and back edge).

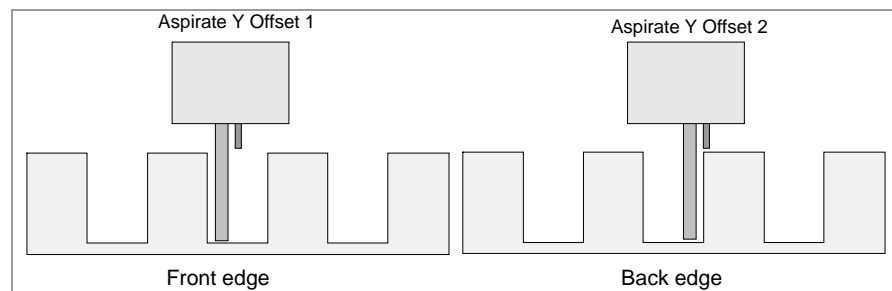

Fig. 4.5 Crosswise Aspiration for Flat Bottom Wells

**WARNING**

TO ENSURE PROPER WASH PERFORMANCE IT IS MANDATORY TO ADJUST THE HYDROFLEX TO THE TYPE / MANUFACTURER OF MICROPLATE OR STRIP-PLATE USED. THIS ALSO APPLIES FOR ANY PRE-DEFINED PLATE FILE, THAT WILL ALWAYS CONTAIN AVERAGE PLATE PARAMETERS ONLY, THAT HAVE TO BE VERIFIED WITH THE CORRESPONDING PLATE TYPE AND IF NECESSARY CORRECTED BEFORE PUTTING THE HYDROFLEX INTO USE.

IF THIS ADJUSTMENT PROCEDURE IS NOT PERFORMED PROPERLY, THIS MIGHT RESULT IN HIGH LEVELS OF RESIDUAL VOLUME PER WELL, AS WELL AS INSUFFICIENT WASHING OF THE WELLS AND MAY SERIOUSLY AFFECT ASSAY PERFORMANCE. FOR DETAILS ON HOW TO ADJUST THE HYDROFLEX TO THE TYPE OF MICROPLATE OR STRIP-PLATE USED, SEE CHAPTER 6 SETTINGS MENU IN THIS MANUAL.

4.7 Drip Mode

The slowest dispensing mode is drip mode.

Drip mode is used for very sensitive applications, e.g. washing cell layers, because the instrument offers the possibility to dispense liquid in small drops. This minimizes the detachment of cells and increases the remaining cell percentage at the bottom of the wells.

The following example shows a typical wash program for working with adherent cells (as it would appear in the Define/Edit menu, see 5.2.2 Define/Edit a Program (Define/Edit Menu) for further information about defining programs).

**Note**

The following example program should not be used as a standard wash procedure for cell washing as it is necessary to adjust the wash parameters, such as Z-position "MOVE CUST.", dispensing and aspirating rates, head speed, etc., according to the cell type used.

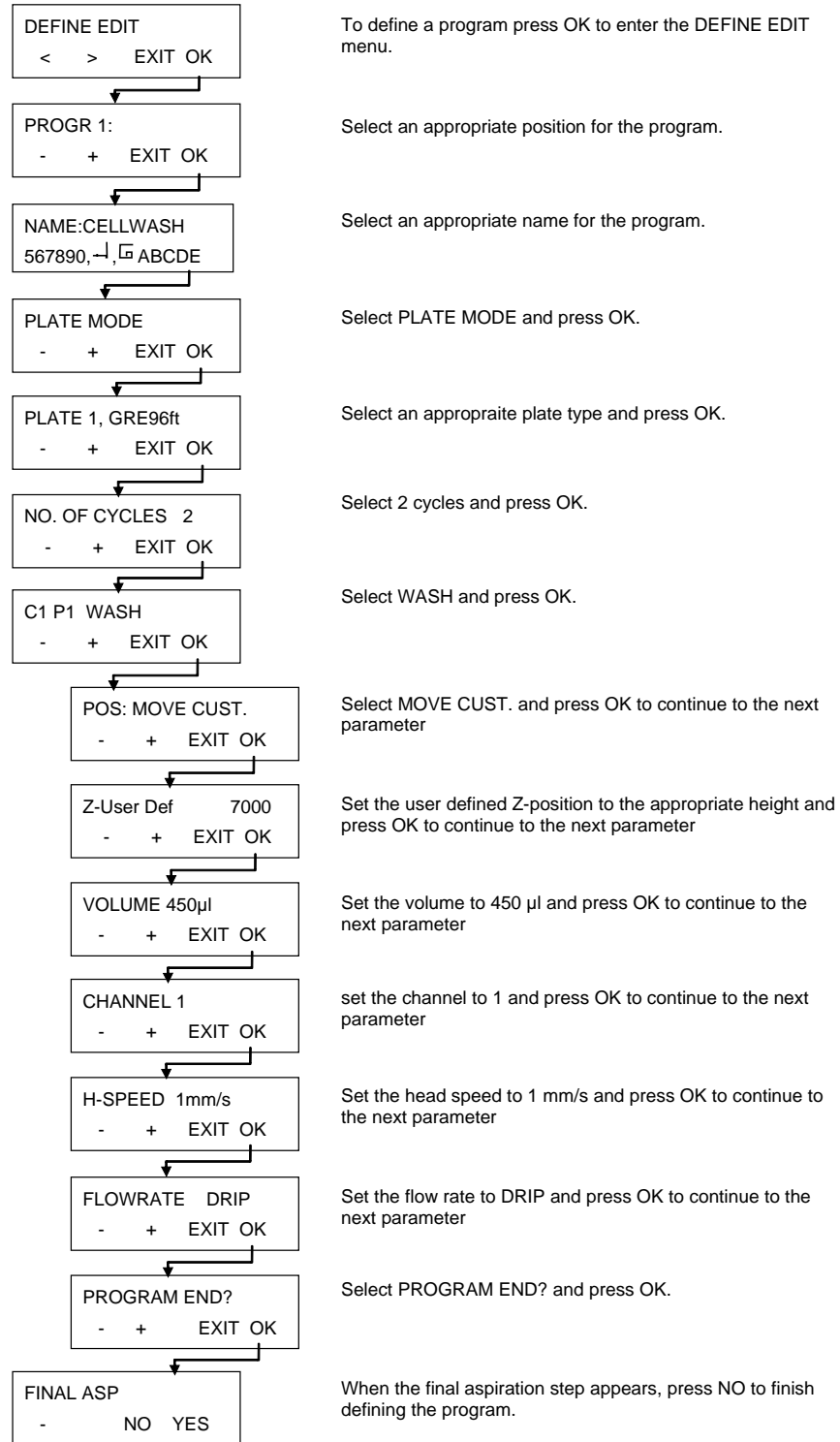

Figure 4.6 Example of a typical wash program for working with adherent cells

4.8 End of Operation

At the end of operation, the instrument can be either left switched on with the manifold in the rinsing solution or switched off after the correct maintenance has been performed.

4.8.1 Instrument Left Switched On

If the instrument will be left to stand for a short time (i.e. up to 2 hours), perform Rinse Day with distilled water or wash buffer.

1. Place the liquid tube into a bottle containing distilled water or wash buffer.
2. Use the **Rinse Day** rinsing procedure to rinse the wash system (see chapter Rinse Day on page 60).
3. When the rinsing procedure is completed the following message is displayed:

RINSE DAY STOP END

4. The manifold remains in the prime tray until END is pressed. Press STOP to abort the procedure (prime tray will not be aspirated).

If the instrument is left to stand for a longer period of time (e.g. overnight), use the following procedure to leave the instrument switched on with the manifold soaking in the distilled water at the end of operation:

1. Place the liquid tube into a bottle containing distilled water.
2. Use the **Rinse Night** rinsing procedure to rinse the wash system (see chapter Rinse Night on page 61).
3. When the rinsing procedure is completed the following message is displayed:

RINSE NIGHT STOP END

4. The manifold remains in the prime tray until END is pressed. Press STOP to abort the procedure (prime tray will not be aspirated).

4.8.2 Instrument Switched Off

If the instrument is to be switched off at the end of operation, the Rinse Night procedure should be performed before switching off the instrument to prevent the needles from becoming blocked.

1. Place the liquid tube into a bottle containing distilled water or deionized water.
2. Use the Rinse Night procedure to rinse the wash system (see chapter Rinse Night on page 61).
3. When the rinsing procedure is completed the following message is displayed:

RINSE NIGHT STOP END

4. The manifold remains in the prime tray until END is pressed. Press STOP to abort the procedure (prime tray will not be aspirated).
5. If the instrument will be left to stand for a long period of time (i.e. more than 1 day), prime the instrument without liquid to remove all liquid from the liquid system.
6. Switch the instrument off.

If the manifold is to be soaked overnight, do not switch the instrument off!

5. Programming Procedure

5.1 Introduction

The following program items are available:

CYCLE:	The number of cycles the subsequent processing steps should be performed
ASP:	An aspirate step removes liquid from the wells.
DISP:	A dispense step fills the wells with liquid.
WASH:	Liquid is dispensed and aspirated simultaneously creating a circular flow with a maximum volume of 3000 µl in one wash step for increased wash efficiency.
SOAK:	During a soak step the liquid remains in the wells for the set time (with or without shaking).
USER PROMPT:	User interaction is requested.
FINAL ASPIRATE:	An aspirate step at the end of a program.
END PROGRAM:	The program finishes.

5.2 Program Menu

The **Program** menu has the following options:

Start	Run a defined wash program.
Define/Edit	Define or edit a program on the instrument.
Show	View the parameters of a defined program.
Clear	Clear a wash program from the instrument's menu.

The **Program** menu has the following structure:

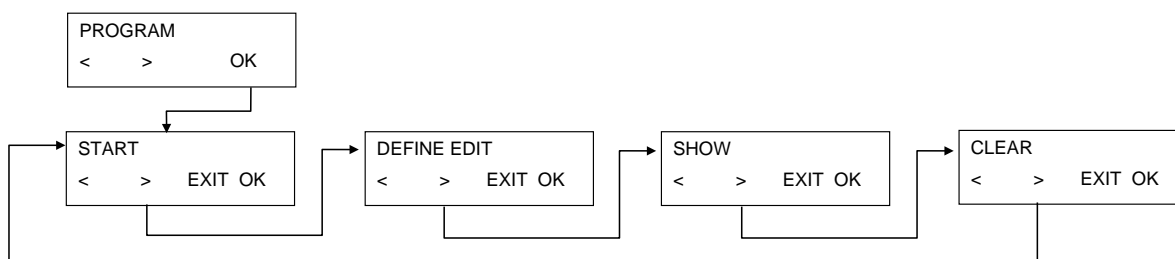

5. Programming Procedure

5.2.1 Starting a Program

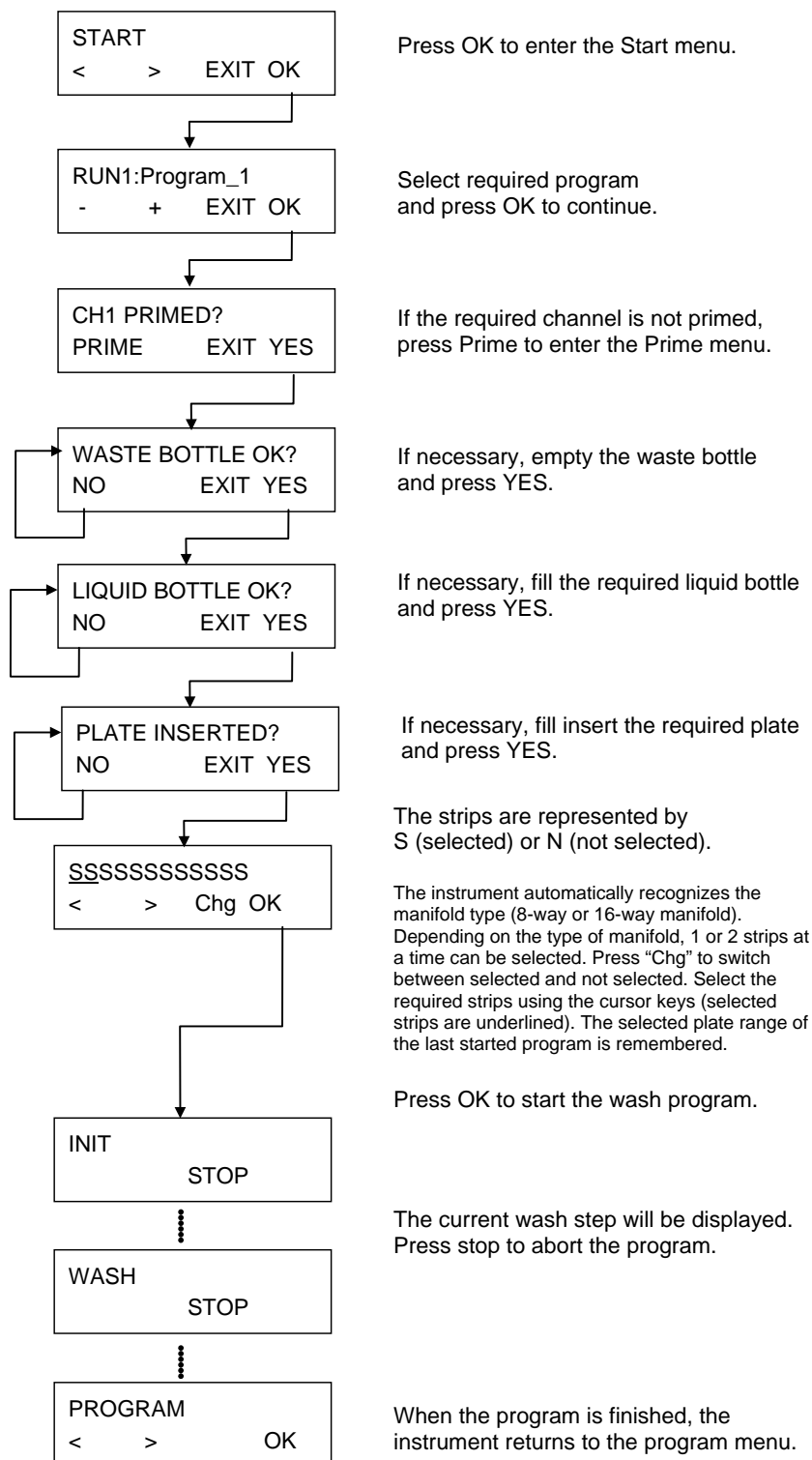

5.2.2 Define/Edit a Program (Define/Edit Menu)

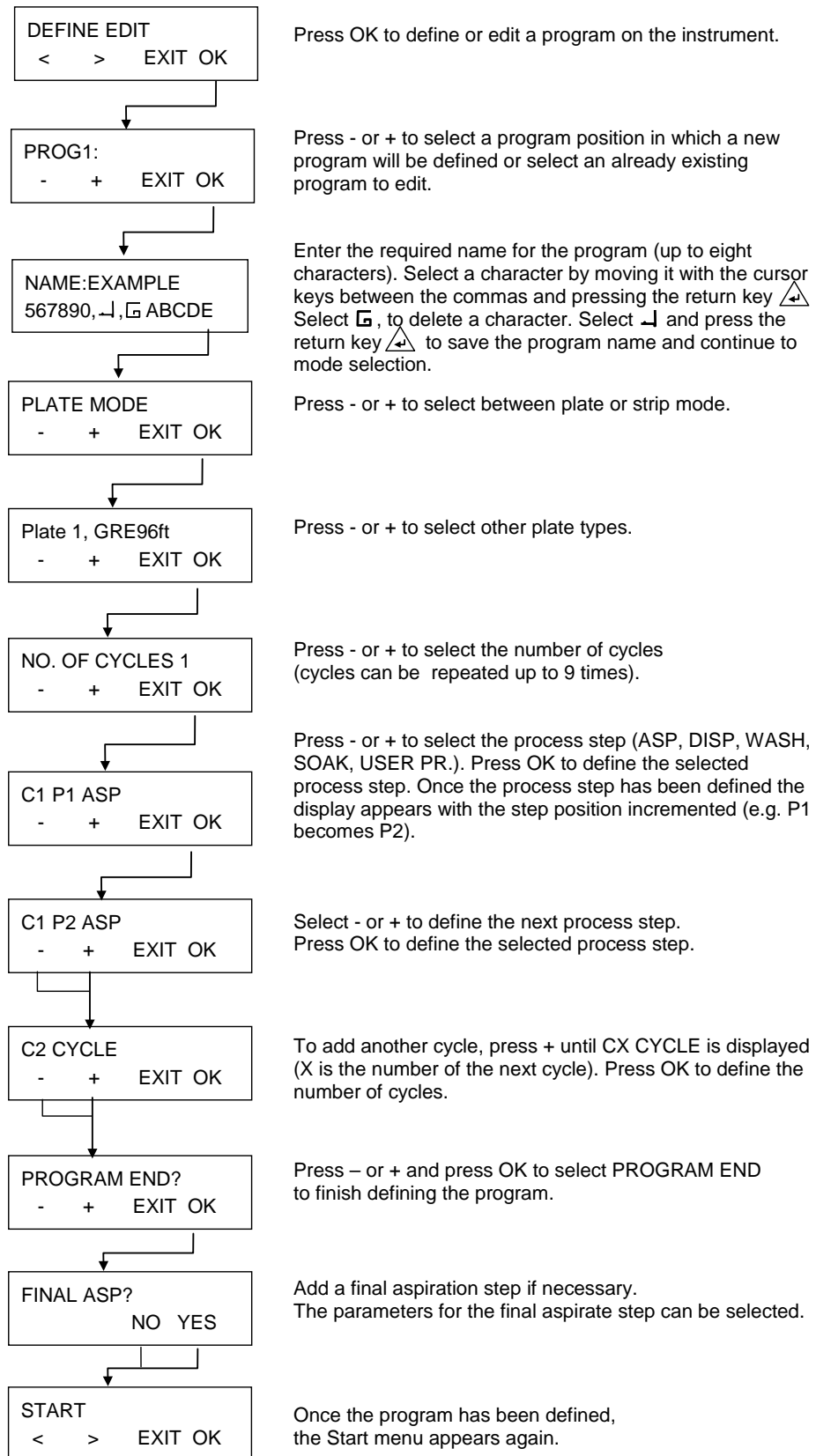

5. Programming Procedure

5.2.3 Process Step: Aspirate

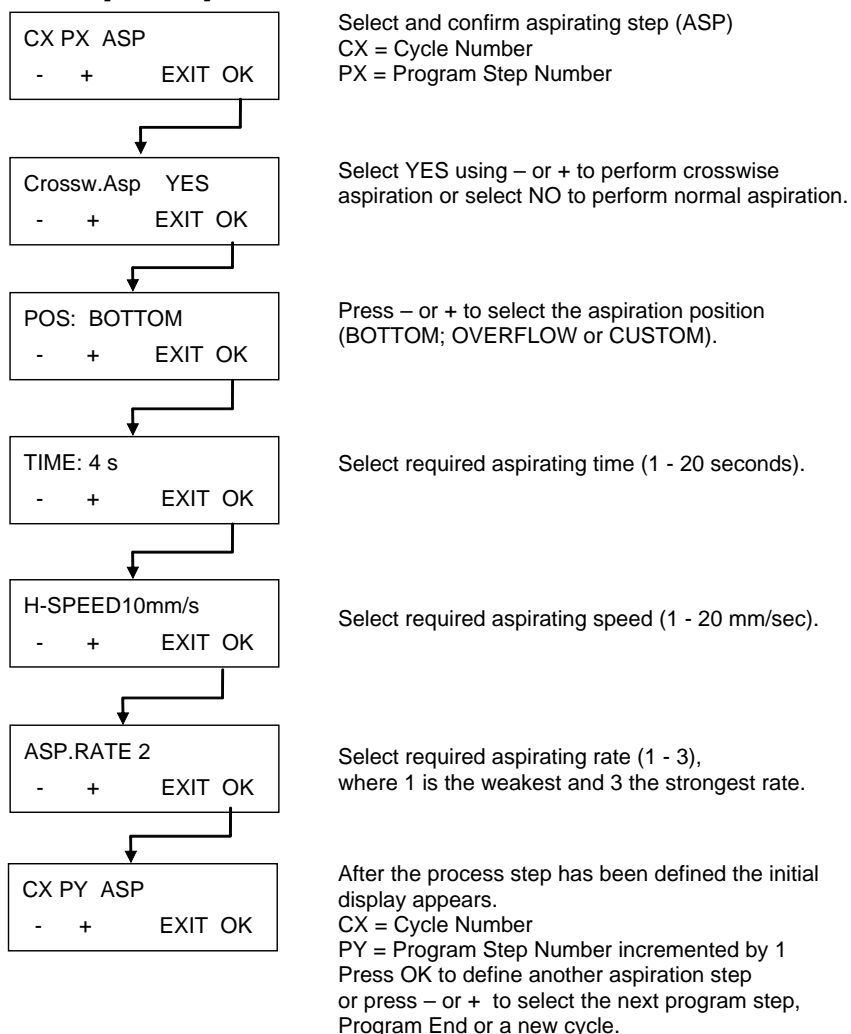

WARNING

RESIDUAL VOLUME OF $\leq 2 \mu\text{L}$ / WELL CANNOT BE GUARANTEED IF NOT ALL WELLS IN A STRIP ARE FILLED WITH LIQUID. TO PREVENT CROSS CONTAMINATION THE HEAD SPEED SHOULD BE LOWERED.

Aspiration Position Diagrams

For further details, see also 4.5 Washing Positions.

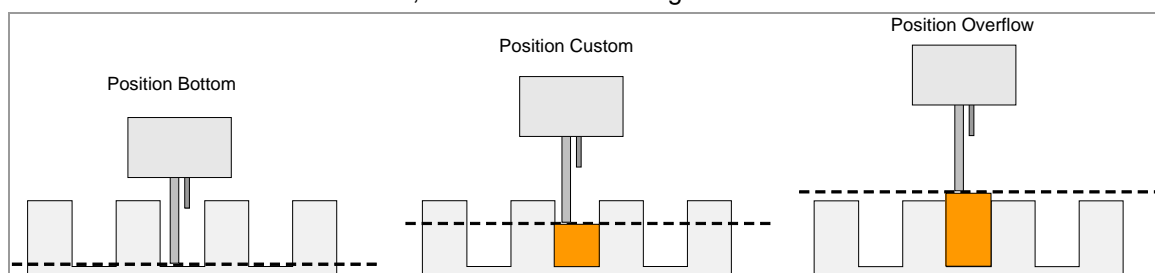
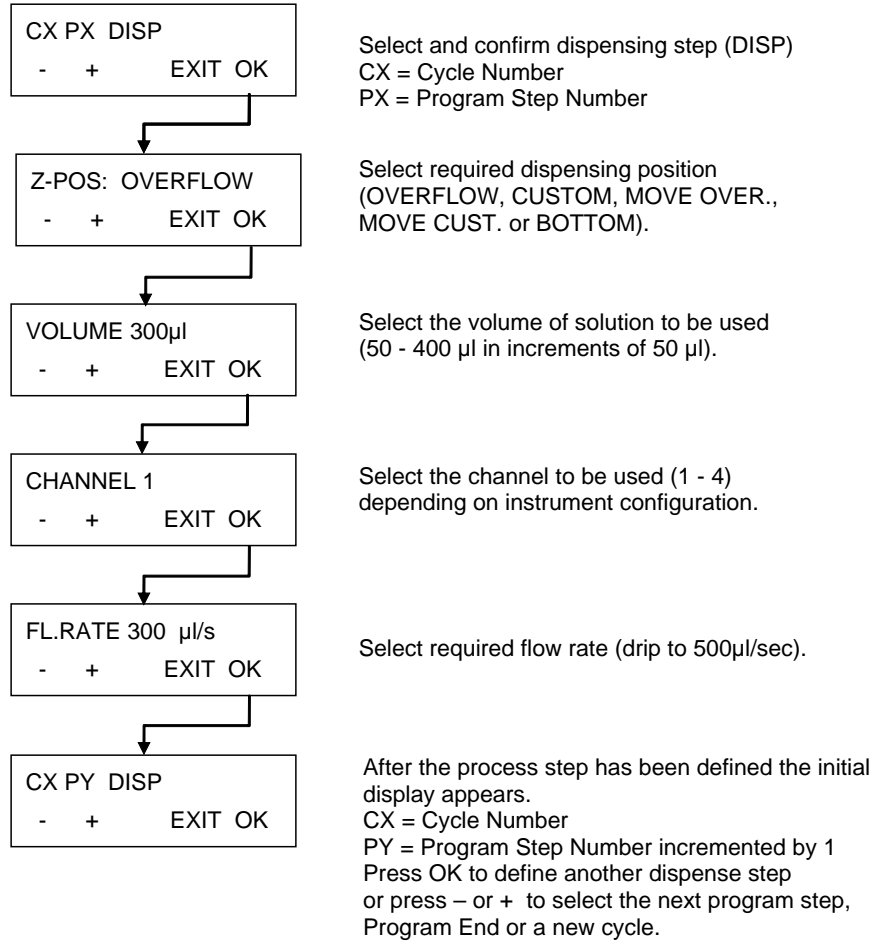

Figure 5.1 Aspiration Position Diagrams

5.2.4 Process Step: Dispense



Dispensing Position Diagrams

For further details, see also 4.5 Washing Positions.

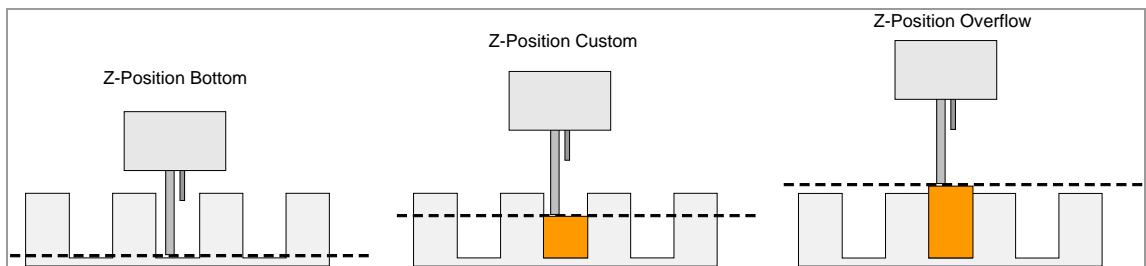

Figure 5.2 Z-Position Diagrams

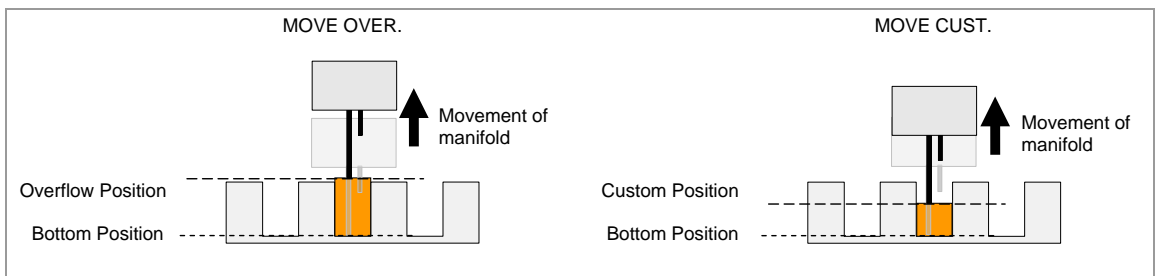
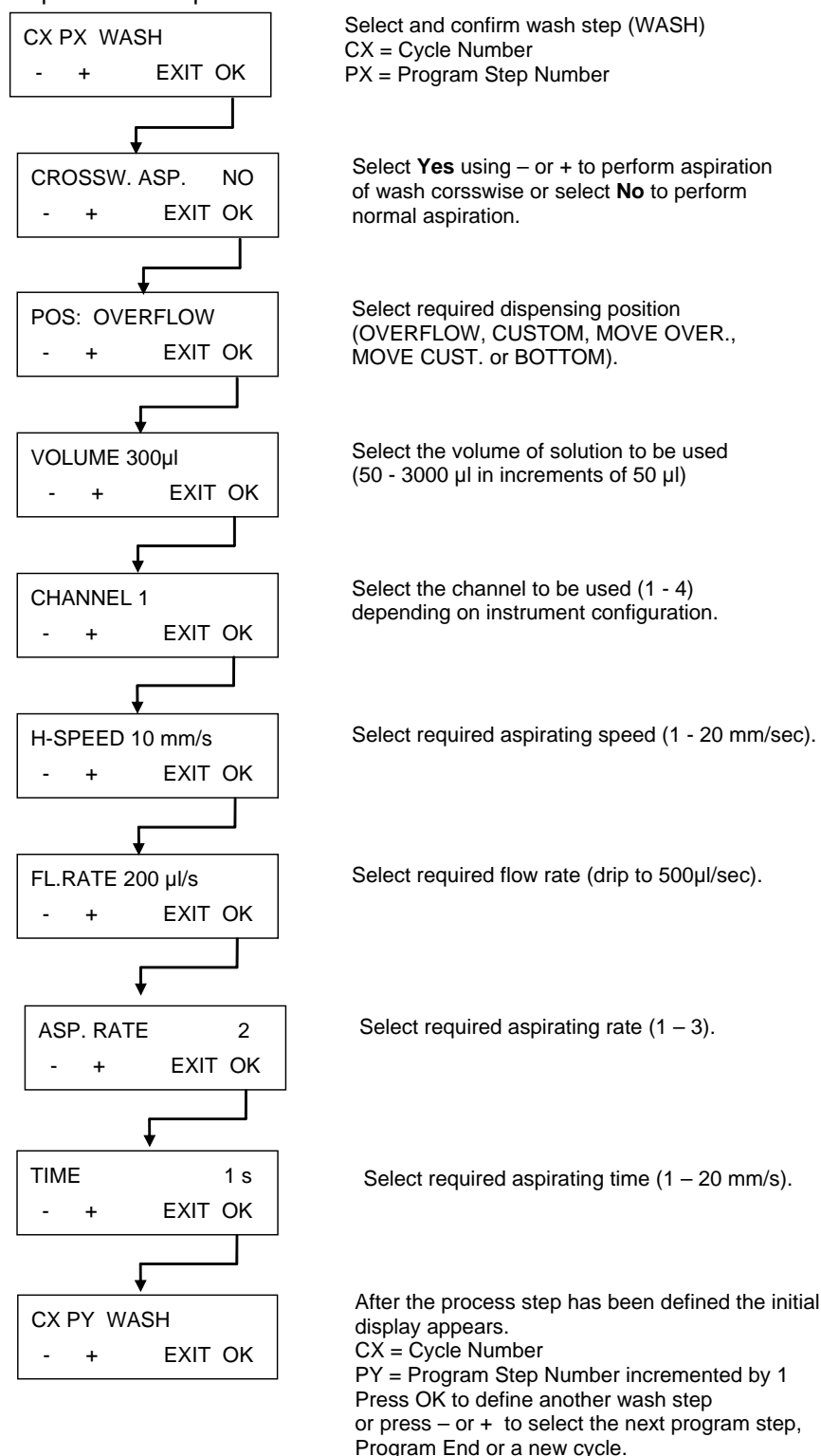

Figure 5.3 Movement Diagrams for Z-positions with MOVE

5. Programming Procedure

5.2.5 Process Step: Wash

This process step is used to aspirate solution out of the wells and simultaneously dispense and aspirate the solution.



For further details, see also 4.5 Washing Positions.

5.2.6 Process Step: Soak

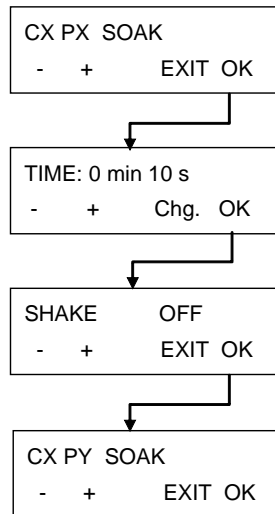

Select and confirm soak step (SOAK).
 CX = Cycle Number
 PX = Program Step Number

Select required soaking time using +/- keys
 (0 – 60 min; 1 - 59 seconds)
 Press Chg. to select minutes or seconds.

The shaking speed can be selected
 (OFF, LOW, MEDIUM or HIGH).

After the process step has been defined the initial display appears.
 CX = Cycle Number
 PY = Program Step Number incremented by 1
 Press OK to define another soak step
 or press – or + to select the next program step,
 Program End or a new cycle.

5.2.7 Process Step: User Prompt

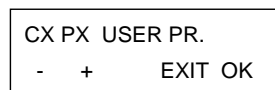

Select and confirm User Prompt strip on
 required position in current program.

5. Programming Procedure

5.3 Show Program

This submenu is used to display the parameters that have been defined for a program. An example wash program containing one cycle, one wash step and a final aspiration step will be used to demonstrate this menu.

The displayed parameter settings cannot be altered in this submenu.

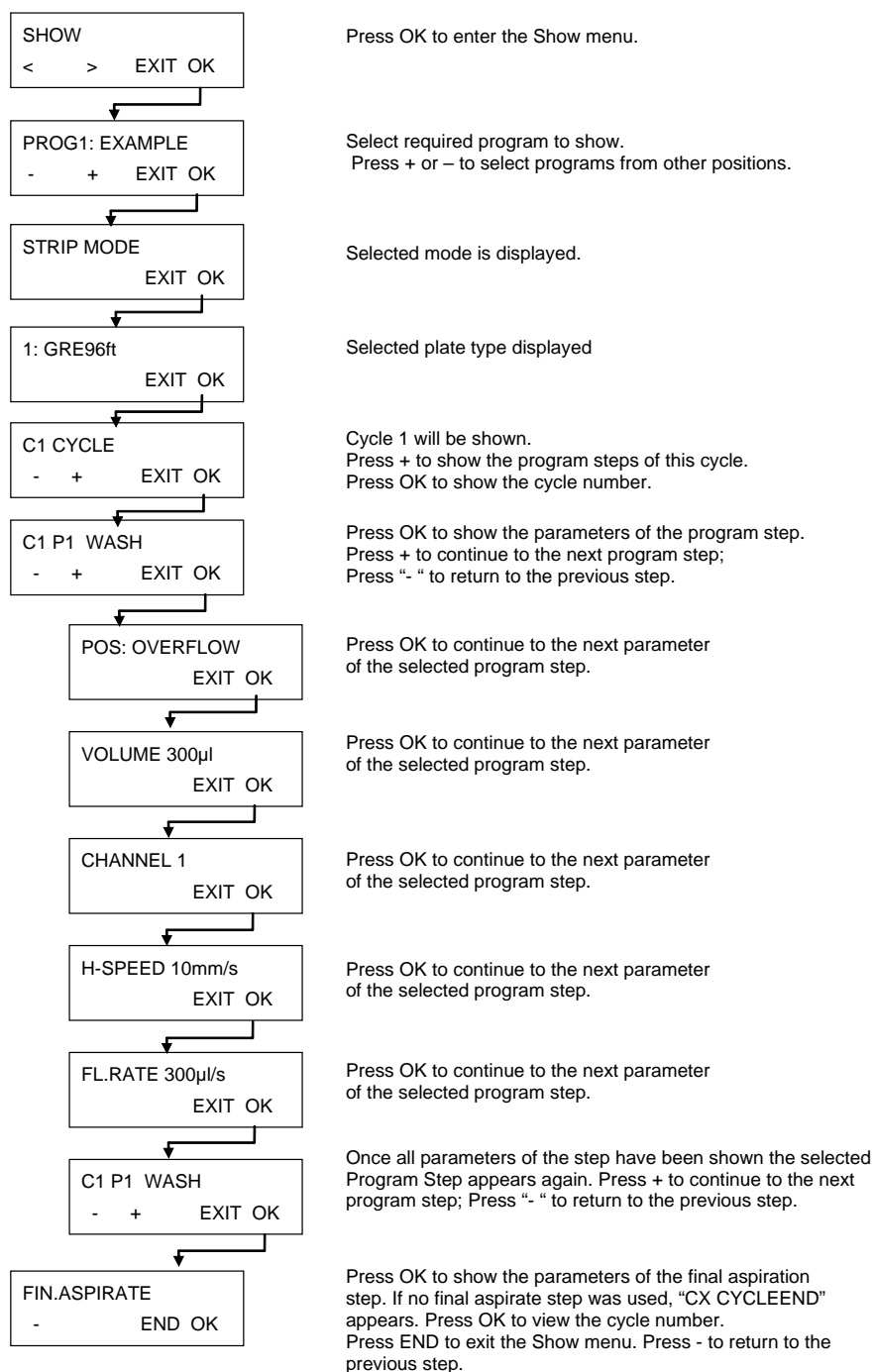

5.4 Clear Program

This submenu is used to clear a program from the instrument's memory.

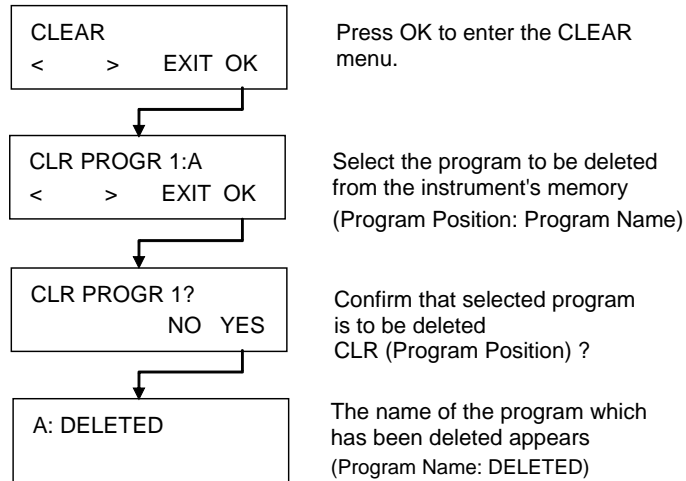

If the program is locked it cannot be cleared and the following message is displayed:

PROGRAM IS
LOCKED

The program can only be unlocked via the HydroControl software, by users with the appropriate rights.

6. Settings Menu

6.1 Introduction

The **Settings** menu has the following options:

Edit Plates	Adjustment procedure for setting the parameters for up to 20 different microplates.
Options	Depending on available options (e.g. Edit LLD Channels).
Bubble Sensor	The Bubble Sensor sensitivity can be set to Low , Medium , or High depending on liquids used (if this option is installed). If very foamy liquids are used the bubble sensor should be switched OFF .

The **Settings** menu has the following structure:

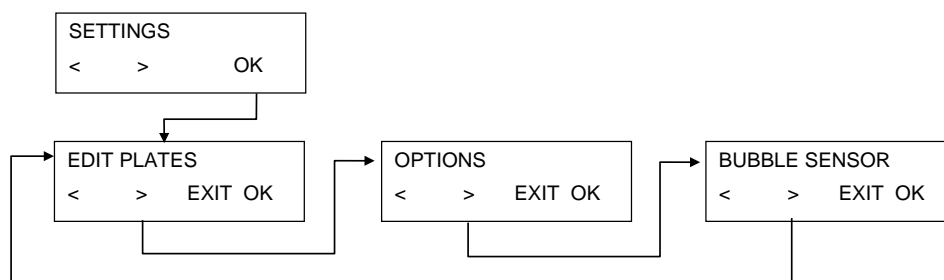

6.1.1 Edit Plates

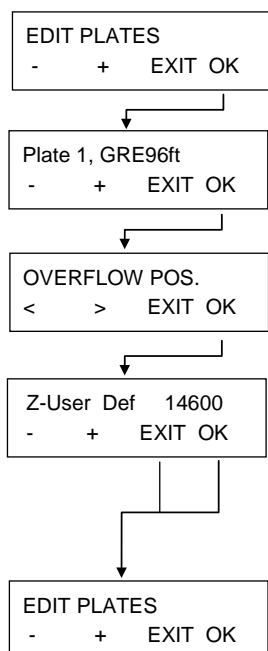

Press OK to continue.

Press – or + to select the plate (1-20) and press OK to edit the plate parameters.

Use the cursor keys to select the position to be defined (OVERFLOW, BOTTOM, ASP1 or ASP2) and press OK. For round and V-shaped bottom plates, only one aspiration can be defined.

The instrument moves to the predefined position. Use the – and + keys to change the position. Confirm with OK. The next position can then be selected.

Press OK to save the defined position; Press EXIT to leave the menu without saving the position. The instrument moves to the home position and the firmware returns to the Edit Plates menu.

6. Settings Menu

6.1.2 Options Submenu

The **Options** submenu has the following structure:

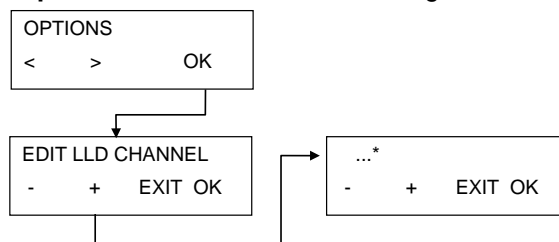

* Depending on available options

Edit LLD Channel

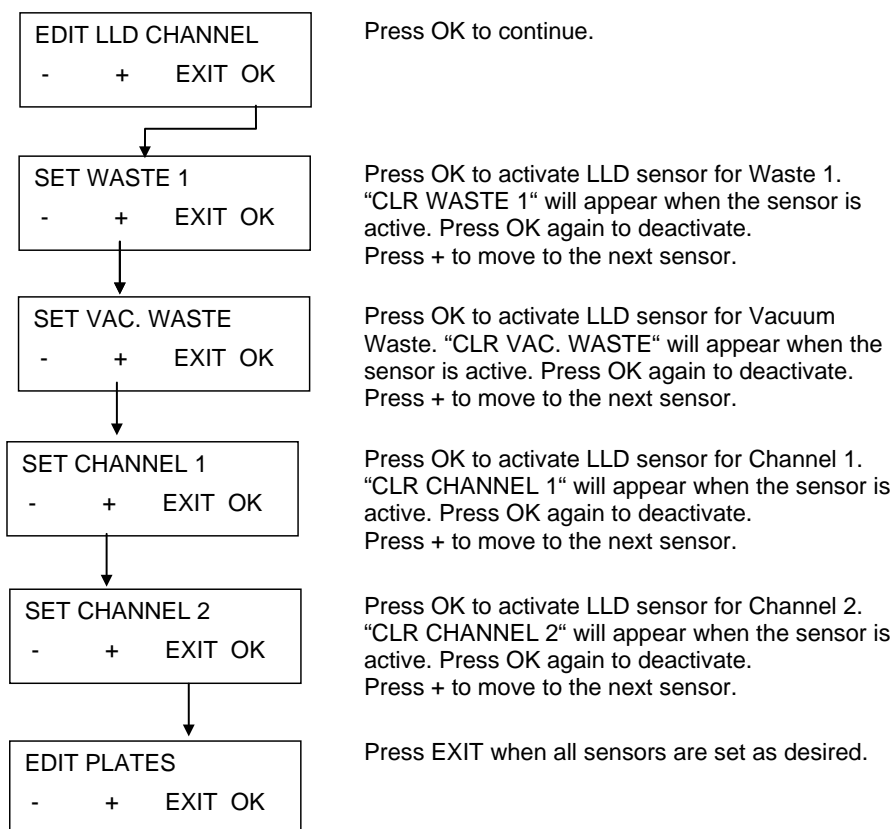

Press OK to continue.

Press OK to activate LLD sensor for Waste 1. "CLR WASTE 1" will appear when the sensor is active. Press OK again to deactivate. Press + to move to the next sensor.

Press OK to activate LLD sensor for Vacuum Waste. "CLR VAC. WASTE" will appear when the sensor is active. Press OK again to deactivate. Press + to move to the next sensor.

Press OK to activate LLD sensor for Channel 1. "CLR CHANNEL 1" will appear when the sensor is active. Press OK again to deactivate. Press + to move to the next sensor.

Press OK to activate LLD sensor for Channel 2. "CLR CHANNEL 2" will appear when the sensor is active. Press OK again to deactivate. Press + to move to the next sensor.

Press EXIT when all sensors are set as desired.

6.1.3 Bubble Sensor

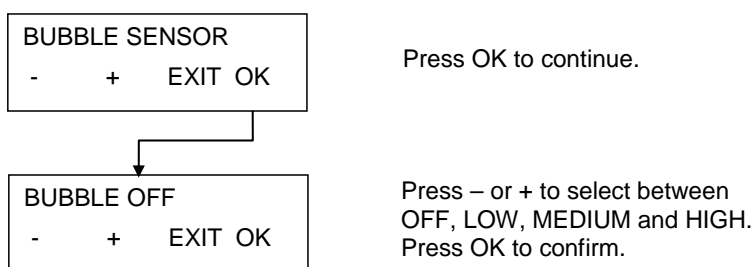

Press OK to continue.

Press – or + to select between OFF, LOW, MEDIUM and HIGH. Press OK to confirm.

6.2 Procedures Menu

The **Procedures** menu has the following options:

- Rinse** Start rinse procedures.
- Prime** Start prime procedures.
- Empty Prime Tray** Aspirate liquid out of the prime tray.

The **Procedures** menu has the following structure:

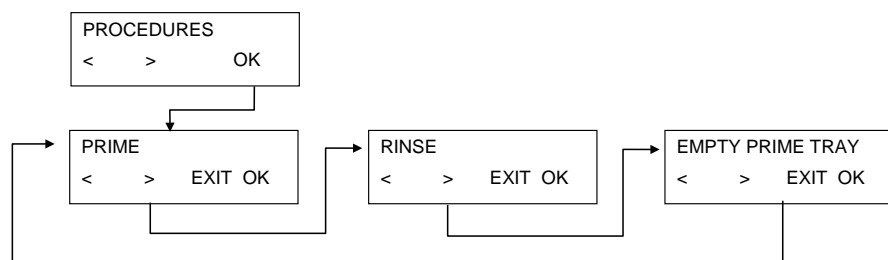

6.2.1 Rinse

For details, see chapter 8.1 Rinsing.

6.2.2 Prime

For details, see chapter 8.2 Priming.

6.2.3 Empty Prime Tray

Press OK and the prime tray will be aspirated.

7. Performance Testing/ Quality Control Using Gravimetric Method

This chapter describes a QC-procedure for the HYDROFLEX allowing to check the residual volume and dispense accuracy of the instrument by weighing a Greiner-F 96-well plate (flat-bottom) on a calibrated lab balance.



Note

To ensure the proper performance of the HYDROFLEX with the QC-test procedure described below, it is necessary to adjust the instrument to the Greiner-F 96-well plate type prior to running this procedure.

If this adjustment procedure is not performed properly, this might result in high levels of residual volume left per well and can lead to failure of the performance test.

For details on how to adjust the HYDROFLEX to the type of microplate or strip-plate used, see chapter 6 Settings Menu of this manual.

Necessary Tools

- Calibrated lab-balance including cover for wind-protection, capable of reading milligrams
- Greiner F 96-well, flat-bottom, compact microplate
- Small plastic syringe to aliquot Tween 20 solution
- Clean 2.5 liter wash buffer bottle supplied with HYDROFLEX
- 5 liter waste bottle supplied with HYDROFLEX

Necessary Chemicals

- 1 liter of distilled water (alternatively deionized water can be used)
- 0.1% Tween 20 solution

Preparation of Solution for QC Procedure

- Prepare a 0.1% Tween 20 solution (1 liter of distilled or deionized water and 1 ml Tween 20).
- Fill solution in empty 2.5 liter wash-buffer bottle supplied with the HYDROFLEX, mix thoroughly and connect tubing to the appropriate channel on the rear panel of the instrument.



Note

The solution for the QC-procedure can be stored for a maximum of 1 month under refrigeration. If the solution becomes turbid, it must be disposed of and replaced with a fresh solution.

7. Performance Testing/ Quality Control

Programs Necessary for QC Procedure

Define the following programs to perform QC procedures:

QCDISP

1. Plate Mode
2. Plate Type: Greiner 96-well flat bottom
3. One Cycle
4. One Dispense step with the following parameters:
 - POS: OVERFLOW
 - VOLUME 200 μ l
 - CHANNEL 1
 - DISPENSE RATE 200 μ l/s

QCASP

1. Plate Mode
2. Plate Type: Greiner 96-well flat bottom
3. One Cycle
4. One Aspiration step with the following parameters:
 - Crossw. ASP
 - POS: BOTTOM
 - TIME: 4 s
 - H-SPEED 10 mm/s
 - ASP.RATE 3

Residual Volume Check



Note

Ensure that lab balance is calibrated. Ensure that the HYDROFLEX and the waste and liquid bottles are placed at the same height on a vibration-free surface according to the manufacturer's guidelines.

Record serial number of lab balance and the HYDROFLEX used, as well as name of operator for documentation purposes.

1. Connect HYDROFLEX to waste bottle as described in this manual in 2.4.2 Rear Panel Connections.
2. Connect wash-buffer bottle containing solution for QC-procedure to channel 1 of HYDROFLEX as described in this manual in 2.4.2 Rear Panel Connections.
3. Prime channel 1 of the HYDROFLEX for 10 seconds as described in 8.2 Priming.
4. Weigh empty and dry Greiner96ft specified above on lab-balance and record TARE.
5. Load Greiner-F microplate on HYDROFLEX to be checked and start program QCDISP to dispense 200 μ l of liquid into each well.
6. Weigh the filled microplate and record the weight. Check dispensing accuracy visually.
7. Start program QCASP to remove the dispensed liquid out of the wells.
8. Place Greiner-F plate back onto lab balance and record weight of remaining liquid.

Interpretation of Results for Residual Volume Check

1. Pass: average residual volume per plate has to be ≤ 0.190 grams.
2. Fail: average residual volume per plate > 0.190 grams.

Interpretation of Results for Dispense Accuracy

1. Pass: dispense accuracy per plate must be ≥ 18.8 grams and ≤ 19.6 grams.
2. Fail: dispense accuracy is outside of the above mentioned range.

Troubleshooting the QC Procedure

1. If the HYDROFLEX has failed the above tests, perform thorough cleaning step using RINSE NIGHT procedure (see Rinse Night on page 61).
2. Disinfect manifold according to procedure described in chapter 8.8 Instrument Disinfection of this manual.
3. Clean the manifold using the provided cleaning-tool for aspiration needles.
4. Repeat QC-procedure mentioned above.
5. If results still fail, inform service technician.



WARNING

ALL PARTS OF THE INSTRUMENT THAT COME INTO CONTACT WITH POTENTIALLY INFECTIOUS MATERIAL MUST BE TREATED AS POTENTIALLY INFECTIOUS AREAS.

IT IS ADVISABLE TO ADHERE TO APPLICABLE SAFETY PRECAUTIONS, (INCLUDING THE WEARING OF POWDER-FREE GLOVES, SAFETY GLASSES AND PROTECTIVE CLOTHING) TO AVOID POTENTIAL INFECTIOUS DISEASE CONTAMINATION WHEN PERFORMING CLEANING PROCEDURES AND ALSO WHEN MAKING ADJUSTMENTS TO THE INSTRUMENT.

8. Maintenance and Cleaning

8.1 Rinsing

Rinsing is performed to flush the liquid system and to prevent needle blockages. During the rinse procedures, the needles are soaked in the prime tray.

The rinsing procedure should be performed, if the instrument is left to stand or is switched off at the end of operation.

8.1.1 Rinse Menu

The **Rinse** menu has the following options:

Rinse Day Perform **Rinse Day**, if the instrument will be left to stand for a short time (up to two hours). When Rinse Day is selected, a **Time** (how long the instrument rinses before the manifold is soaked in the prime tray) can also be selected (5 - 99 seconds). Rinse Day can be performed with wash buffer or distilled water.

Rinse Night Perform **Rinse Night** for thorough rinsing and if the instrument will be left to stand for a longer time with the manifold soaking in distilled or deionized water (e.g. overnight). When Rinse Night is selected the **Time** cannot be set. Rinse Night must be performed with distilled water only.

The **Rinse** menu has the following structure:

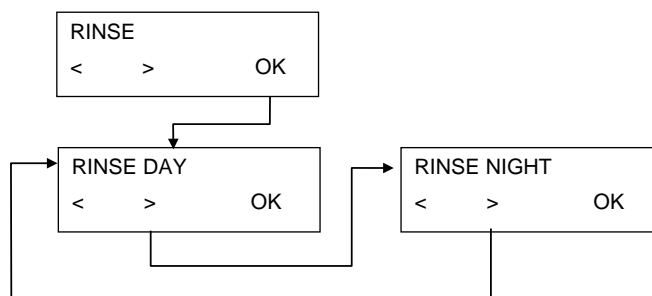

8. Maintenance and Cleaning

Rinse Day

This procedure is used to rinse the liquid system if the instrument is to be left to stand for up to 2 hours, for longer times use Rinse Night (see Rinse Night on page 61).

Alternatively, it can be used to rinse the liquid system after the instrument has been left for a long time.

Distilled water or a wash buffer can be used with this procedure.

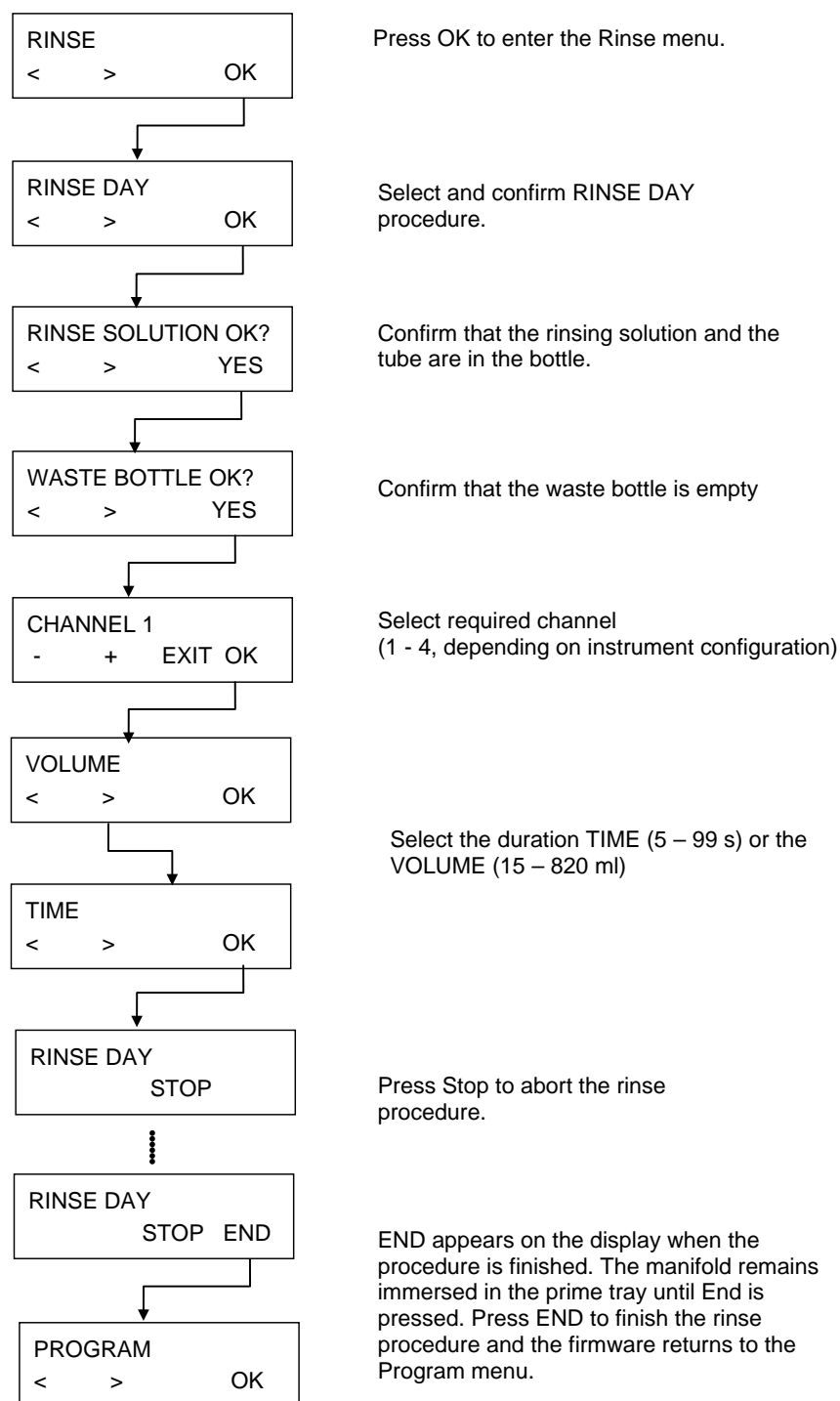

Rinse Night

This procedure is used to thoroughly rinse the liquid system and then soak the manifold in the prime tray full of solution at the end of operation.

Use only distilled water with this procedure.

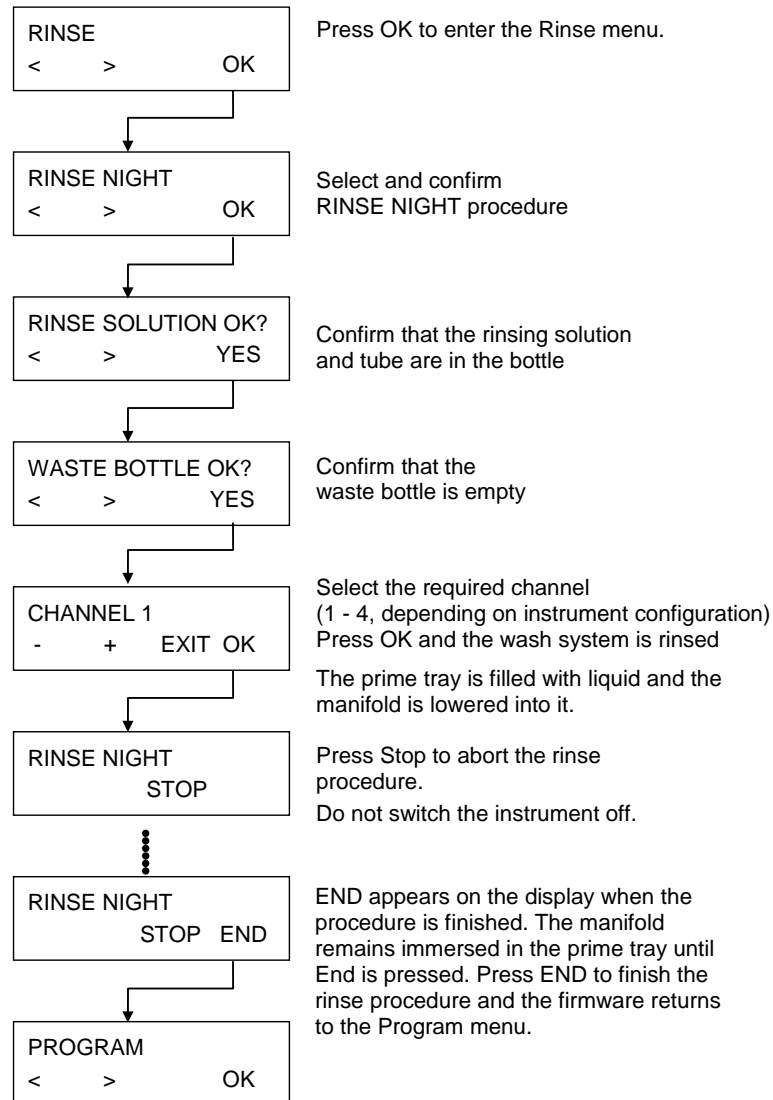

8.2 Priming

Priming is performed to fill the liquid system of the HYDROFLEX with liquid and to remove all air from the tubes. A priming step must also be performed when switching between buffers.

If different wash buffers are used in a wash program, the instrument performs a prime step automatically before switching to the next liquid. A prime step is also automatically performed before a program is started.

If the instrument will be left to stand for a longer time, priming must be performed to remove all liquid from the system. For this purpose, remove all tubes from the liquid bottles.



WARNING

BEFORE THE INSTRUMENT IS USED, ALL DISPENSING CHANNELS NEEDED FOR THE WASH PROGRAM MUST BE PRIMED TO FILL THE LIQUID SYSTEM WITH THE REQUIRED LIQUID.

IF THE PRIMING PROCEDURE IS NOT PERFORMED PROPERLY, THIS CAN RESULT IN INSUFFICIENT WASHING OF THE WELLS AND CAN SERIOUSLY AFFECT ASSAY PERFORMANCE.

ENSURE THAT THE BOTTLE OF THE PRIMING SOLUTION IS ALWAYS FULL AT THE BEGINNING OF THE PRIMING PROCEDURE AND CHECK THAT THE INLET FILTERS IN THE LIQUID TUBES ARE CLEAN.



Caution

Ensure that the dispensing and aspiration pumps are not run for longer than a few minutes without liquid or they will be damaged.



Caution
Do not use the instrument to aspirate or dispense any acidic solutions as this could damage the instrument.

Priming is performed using the following procedure:

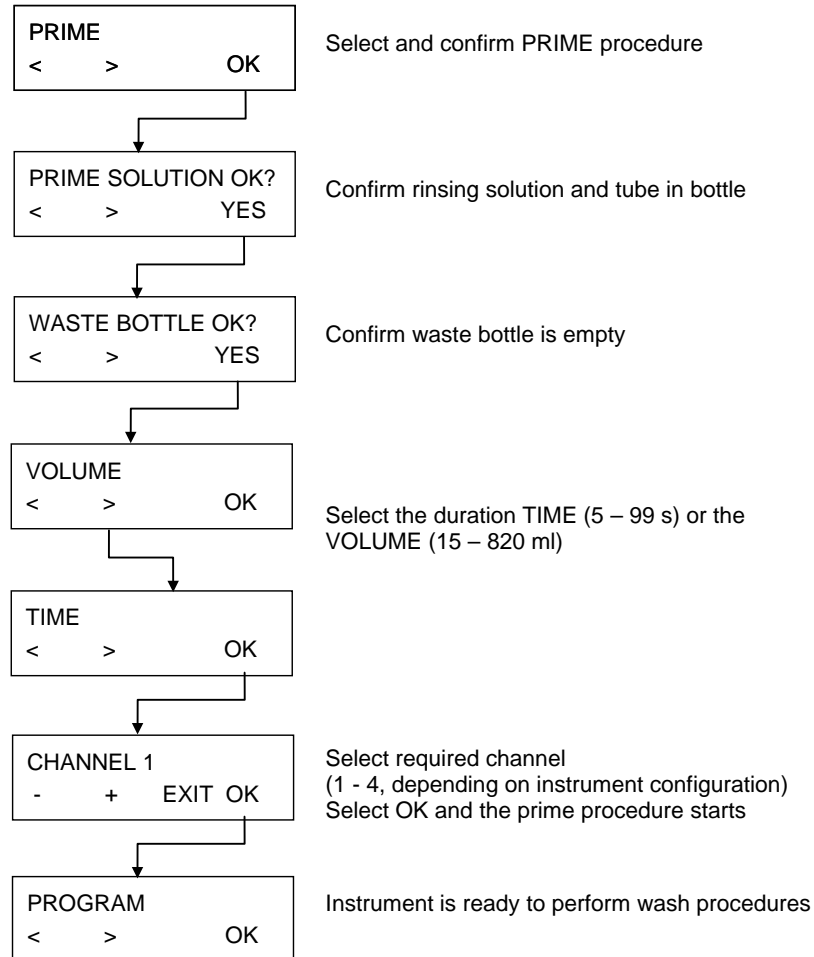

8.3 Cleaning Procedures



WARNING

ALL PARTS OF THE INSTRUMENT THAT COME INTO CONTACT WITH POTENTIALLY INFECTIOUS MATERIAL MUST BE TREATED AS POTENTIALLY INFECTIOUS AREAS.

IT IS ADVISABLE TO ADHERE TO APPLICABLE SAFETY PRECAUTIONS, (INCLUDING THE WEARING OF POWDER-FREE GLOVES, SAFETY GLASSES AND PROTECTIVE CLOTHING) TO AVOID POTENTIAL INFECTIOUS DISEASE CONTAMINATION WHEN PERFORMING CLEANING PROCEDURES AND ALSO WHEN MAKING ADJUSTMENTS TO THE INSTRUMENT.

The most important cleaning procedure for this instrument is to rinse the liquid system with distilled water before the instrument is left to stand or switched off at the end of each day.

The manifold should be removed and thoroughly cleaned at least once every six months or whenever one or more of the needles are blocked.

8.3.1 *Cleaning the Cover and Display*

The outer surface of the instrument and the display may be cleaned periodically using a tissue moistened with a mild detergent solution (see chapter 8.5 Preventive Maintenance Plan).



Caution

Never use Acetone as it will damage the covers.

8.3.2 *Cleaning the Liquid System*

To clean the liquid system, perform Rinse and Prime procedures as described in chapter 8.5 Preventive Maintenance Plan.



Caution

If the manifold is not rinsed, the needles will become blocked.
If this occurs, the manifold will need expensive repairs
or will have to be replaced.

The manifold can be cleaned using:

1. The supplied cleaning needles (accessory box). The small cleaning needle is for the dispensing needles and the large cleaning needle is for the aspirating needles.
Carefully push the cleaning needles into the aspirating and dispensing needles. Rinse the manifold block with distilled water to ensure that all particles have been removed.
2. A gentle ultrasonic bath of warm distilled water for 15 minutes
3. Autoclaving (max. 130 °C , max. five times, manifold must be removed from the instrument).
4. Reinstall the manifold if necessary (see chapter 8.6 Replacing the Manifold).
5. After the manifold has been cleaned, switch the instrument on and perform the priming procedure using distilled water.

**Caution**

If additional cleaning is required, use the delivered cleaning needles and adhere to applicable safety precautions, (including the wearing of powder-free gloves, safety glasses and protective clothing) to avoid potential infectious disease contamination.

Cleaning Waste Bottles

Before cleaning the waste bottles empty them according to disposal regulations (see 8.9.3 Disposal of Operating Material).

The bottles must be cleaned regularly depending on the applications, using a mild detergent.

**WARNING**

WHEN HANDLING WASTE BOTTLES, IT IS ADVISABLE TO ADHERE TO APPLICABLE SAFETY PRECAUTIONS, (INCLUDING THE WEARING OF POWDER-FREE GLOVES, SAFETY GLASSES AND PROTECTIVE CLOTHING) TO AVOID POTENTIAL INFECTIOUS DISEASE CONTAMINATION.

8.4 Liquid or Foam Spills



WARNING

ALWAYS SWITCH-OFF THE HYDROFLEX BEFORE REMOVING ANY KIND OF SPILLS ON THE INSTRUMENT.

ALL SPILLS (LIQUID OR FOAM) MUST BE TREATED AS POTENTIALLY INFECTIOUS. THEREFORE, ALWAYS ADHERE TO APPLICABLE SAFETY PRECAUTIONS, (INCLUDING THE WEARING OF POWDER-FREE GLOVES, SAFETY GLASSES AND PROTECTIVE CLOTHING) TO AVOID POTENTIAL INFECTIOUS DISEASE CONTAMINATION.

ADDITIONALLY, ALL RESULTING WASTE FROM THE CLEAN-UP MUST BE TREATED AS POTENTIALLY INFECTIOUS AND THE DISPOSAL MUST BE PERFORMED ACCORDING TO THE INFORMATION GIVEN IN 8.9.3 DISPOSAL OF OPERATING MATERIAL.

IF THE SPILL OCCURS IN THE INSTRUMENT, A SERVICE TECHNICIAN IS REQUIRED.

Spilling of liquid or foam may occur when the HYDROFLEX is operated improperly such as:

1. Used microplate not matching installed manifold.
2. Positions of the strips in the strip-plate do not match the positions defined in the program used for processing.
3. Plate parameters not properly adjusted.
4. Waste bottle not emptied when liquid level or foam level reaches maximum filling level.
5. No anti-foaming agent used with wash buffers showing strong tendency to foam.

Always remove spills immediately after they have occurred. Use paper tissue to soak-up spills and wipe-surface dry.



WARNING

WASTE BOTTLE - LIQUID LEVEL

MAKE SURE THAT THE LIQUID LEVEL OF THE WASTE BOTTLE IS ALWAYS KEPT BELOW THE MAXIMUM LEVEL INDICATED ON THE BOTTLE TO AVOID POTENTIAL OVERFLOW.

THE CONTENTS OF WASTE BOTTLE ARE POTENTIALLY INFECTIOUS, SO IT IS IMPORTANT TO WEAR PROTECTIVE CLOTHING (GLOVES, LAB COAT AND SAFETY GLASSES) WHEN EMPTYING / HANDLING A WASTE BOTTLE.

8.5 Preventive Maintenance Plan



WARNING

ALL PARTS OF THE INSTRUMENT THAT COME INTO CONTACT WITH POTENTIALLY INFECTIOUS MATERIAL MUST BE TREATED AS POTENTIALLY INFECTIOUS AREAS.

IT IS ADVISABLE TO ADHERE TO APPLICABLE SAFETY PRECAUTIONS, (INCLUDING THE WEARING OF POWDER-FREE GLOVES, SAFETY GLASSES AND PROTECTIVE CLOTHING) TO AVOID POTENTIAL INFECTIOUS DISEASE CONTAMINATION WHEN PERFORMING CLEANING PROCEDURES AND ALSO WHEN MAKING ADJUSTMENTS TO THE INSTRUMENT.



WARNING

RISK OF FIRE AND EXPLOSION!

PRIOR TO CLEANING THE OUTER SURFACE OF THE INSTRUMENT AND THE DISPLAY, SWITCH OFF THE INSTRUMENT AND DISCONNECT IT FROM THE MAIN POWER SUPPLY!

8.5.1 Daily

1. Prime the liquid system if necessary.
2. Perform Rinse Day with distilled water or wash buffer, if the instrument is left to stand for a short time (up to 2 hours).
3. Perform Rinse Night only with distilled water, if the instrument is left to stand overnight.
4. If necessary (due to particles, soiling, etc.), prime the instrument several times with distilled water.
5. If the instrument will be left to stand for a longer period of time (more than one day), prime with distilled water and then prime without liquid.

8.5.2 Weekly

1. Perform Rinse Night with distilled water.
2. Prime the instrument without liquid to empty the entire liquid system.
3. Check the filter(s) in the liquid bottle(s) for particles and rinse liquid filter(s) with distilled water.
4. Clean the plate carrier guide bar with 70% ethanol.

8. Maintenance and Cleaning

8.5.3 Every Six Months

1. Clean the plate carrier guide bar with 70% ethanol.
2. Check the centering mechanism of the plate carrier and clean if necessary with 70 % ethanol.
3. Clean the manifold aspirating and dispensing needles using the cleaning needles supplied with the instrument.



Note

Clean the aspirating and dispensing needles periodically or immediately if they become clogged with particles or crystals.

8.5.4 Yearly (Service Engineer Required)

The yearly maintenance is performed by the service engineer.

8.6 Replacing the Manifold



WARNING

**AFTER THE INSTRUMENT HAS BEEN USED,
THE MANIFOLD MAY BE INFECTIOUS!
BEFORE THE MANIFOLD IS REMOVED IT MUST BE THOROUGHLY
DISINFECTED .**

**IT IS ADVISABLE TO ADHERE TO APPLICABLE SAFETY
PRECAUTIONS, (INCLUDING THE WEARING OF POWDER-FREE
GLOVES, SAFETY GLASSES AND PROTECTIVE CLOTHING) TO
AVOID POTENTIAL INFECTIOUS DISEASE CONTAMINATION.**



WARNING

**PRIME THE INSTRUMENT WITHOUT LIQUID TO EMPTY ALL LIQUID
FROM THE SYSTEM, BEFORE REMOVING THE MANIFOLD.**

8.6.1 General Description of the Manifold

The HYDROFLEX is delivered with the manifold already installed.

The instrument can be used with the following types of manifolds:

- Standard 8-way and
- Standard 16-way

The manifolds for the HYDROFLEX have the same basic components:

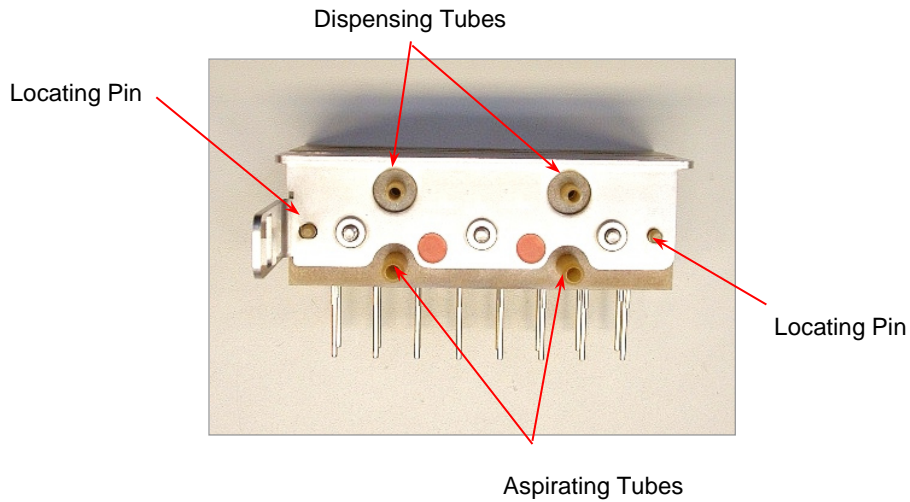

Fig. 8.1 The Rear of the Manifold



Note
Always wear powderfree gloves when handling the manifold.

8. Maintenance and Cleaning

8.6.2 Removing the Manifold



WARNING
PRIME WITHOUT LIQUID TO REMOVE ANY LIQUIDS FROM THE TUBING SYSTEM.

The manifold should be removed and thoroughly cleaned at least once every 6 months or whenever needles become blocked.

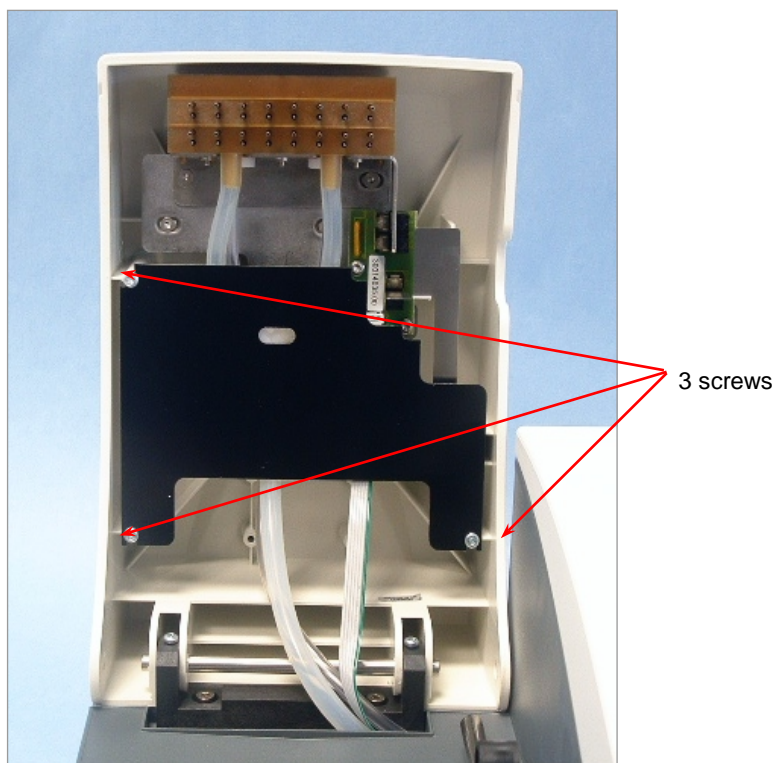

1. Lift the manifold arm and remove the black manifold arm guard plate by sliding it out from behind the three screws – the screws do not need to be removed to perform this step.

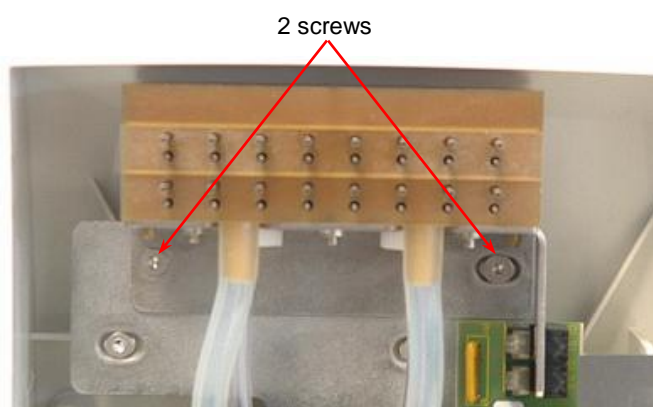

2. Lift the manifold arm and remove the two screws that attach the manifold to the instrument using the Allen key provided.
3. Carefully pull the tubing off the connectors on the rear of the manifold and remove the manifold.

8.6.3 Installing the Manifold



WARNING

ALL PARTS OF THE INSTRUMENT THAT COME INTO CONTACT WITH POTENTIALLY INFECTIOUS MATERIAL MUST BE TREATED AS POTENTIALLY INFECTIOUS AREAS.

IT IS ADVISABLE TO ADHERE TO APPLICABLE SAFETY PRECAUTIONS, (INCLUDING THE WEARING OF POWDER-FREE GLOVES, SAFETY GLASSES AND PROTECTIVE CLOTHING) TO AVOID POTENTIAL INFECTIOUS DISEASE CONTAMINATION WHEN PERFORMING CLEANING PROCEDURES AND ALSO WHEN MAKING ADJUSTMENTS TO THE INSTRUMENT.

The standard manifolds are installed using the following procedure:

1. Lift the manifold arm.
2. Carefully fit the manifold onto the manifold arm and ensure that the locating pins are correctly inserted through the holes in the bracket.

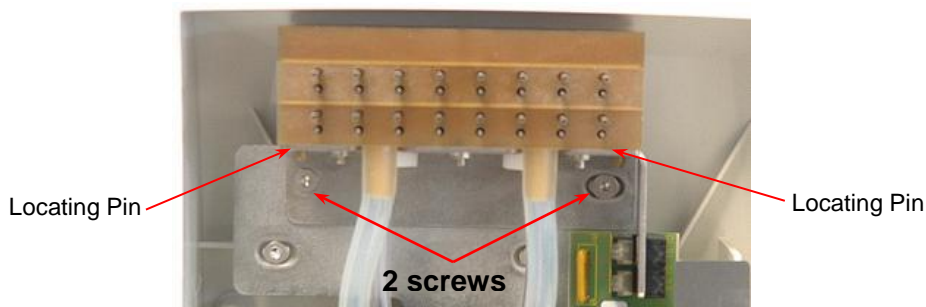

3. Tighten the manifold into place using the two screws using the Allen key provided.
4. Fit the dispensing tubes (marked blue) onto the top connector on the rear of the manifold.
5. Fit the aspirating tubes (marked red) onto the two bottom connectors on the rear of the manifold (marked with red labels).

8. Maintenance and Cleaning

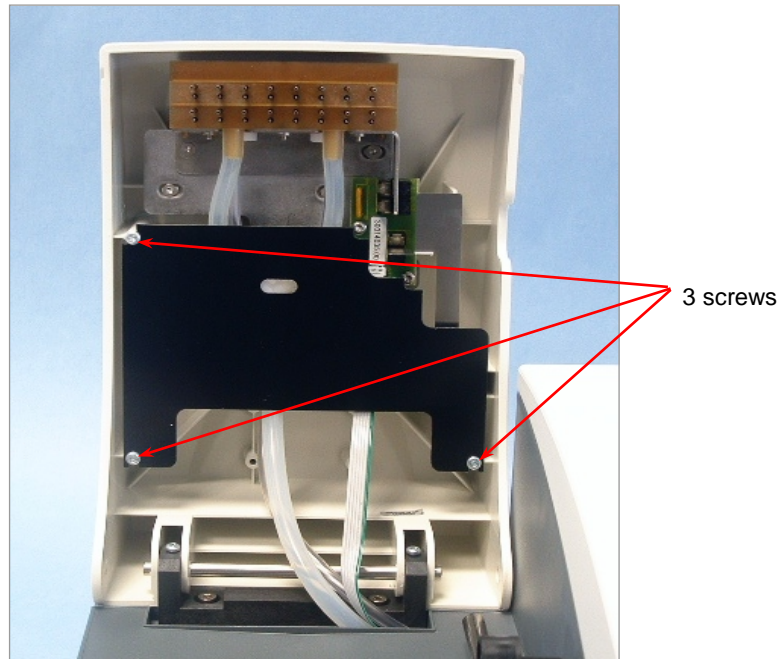

6. Reattach the black manifold guard plate by sliding it into place behind the three screws.
7. Lower the manifold arm and prime the instrument before starting a wash program.

8.7 Replacing the Plate Carrier



WARNING

ALL PARTS OF THE INSTRUMENT THAT COME INTO CONTACT WITH POTENTIALLY INFECTIOUS MATERIAL MUST BE TREATED AS POTENTIALLY INFECTIOUS AREAS.

IT IS ADVISABLE TO ADHERE TO APPLICABLE SAFETY PRECAUTIONS, (INCLUDING THE WEARING OF POWDER-FREE GLOVES, SAFETY GLASSES AND PROTECTIVE CLOTHING) TO AVOID POTENTIAL INFECTIOUS DISEASE CONTAMINATION WHEN PERFORMING CLEANING PROCEDURES AND ALSO WHEN MAKING ADJUSTMENTS TO THE INSTRUMENT.

The instrument is delivered with the plate carrier already installed. If the plate carrier is removed, for example for cleaning, it can be replaced using the following procedure:

1. Switch the instrument off.
2. Lift the manifold arm
3. Slightly tilt the plate carrier towards the right.



4. Carefully slide the plate carrier with the prime tray at the rear over the guide bar.

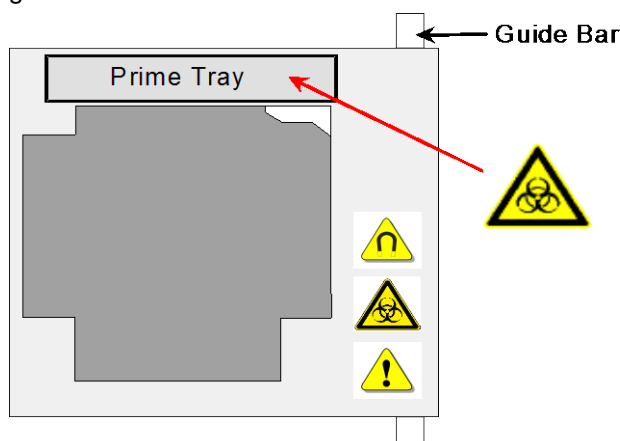

The plate carrier must be slightly tilted so that it goes over the pin that activates the automatic microplate centering mechanism.

To reinstall the plate carrier follow the procedure listed below:

1. Push the plate carrier so that it is fully inserted into the instrument.
2. Lower the plate carrier.
3. Lower the manifold arm.

8.8 Instrument Disinfection



WARNING

THE DISINFECTION PROCEDURE SHOULD BE PERFORMED ACCORDING TO NATIONAL, REGIONAL, AND LOCAL REGULATIONS.



WARNING

ALL PARTS OF THE INSTRUMENT THAT COME INTO CONTACT WITH POTENTIALLY INFECTIOUS MATERIAL MUST BE TREATED AS POTENTIALLY INFECTIOUS AREAS.

IT IS ADVISABLE TO ADHERE TO APPLICABLE SAFETY PRECAUTIONS, (INCLUDING THE WEARING OF POWDER-FREE GLOVES, SAFETY GLASSES AND PROTECTIVE CLOTHING) TO AVOID POTENTIAL INFECTIOUS DISEASE CONTAMINATION WHEN PERFORMING THE DISINFECTION PROCEDURE.

It is very important that the instrument is thoroughly disinfected before it is removed from the laboratory or any servicing is performed on it.

Before the instrument is returned to the service center for service or repair, it must be disinfected and a disinfection certificate completed by the operating authority. If a disinfection certificate is not supplied, the instrument may not be accepted by the service center or it may be held by the customs authorities.

8.8.1 Disinfection Solutions

Use the following disinfection solutions for the disinfection procedure:

- Decon 90 (Decon Laboratories Limited)
- Decon neutracon (Decon Laboratories Limited)
- Microcide SQ (Global Biotechnologies)
- Ethanol



WARNING

**RISK OF FIRE AND EXPLOSION!
ETHANOL IS FLAMMABLE AND WHEN IMPROPERLY HANDLED CAN LEAD TO EXPLOSIONS. PROPER LABORATORY SAFETY PRECAUTIONS MUST BE OBSERVED.**

8.8.2 Disinfection Procedure

The instrument should be disinfected using one of the solutions mentioned in the previous chapter.



WARNING
RISK OF FIRE AND EXPLOSION!
PRIOR TO CLEANING THE OUTER SURFACE OF THE INSTRUMENT AND THE DISPLAY, SWITCH OFF THE INSTRUMENT AND DISCONNECT IT FROM THE MAIN POWER SUPPLY!



Caution
Before starting the disinfection procedure use a rinse procedure (Rinse Day) with distilled or deionized water (lab quality) to flush the system.



WARNING
THE DISINFECTION PROCEDURE SHOULD BE PERFORMED IN A WELL-VENTILATED ROOM BY AUTHORIZED TRAINED PERSONNEL WEARING DISPOSABLE POWDER-FREE GLOVES, PROTECTIVE GLASSES AND PROTECTIVE CLOTHING.

Please note that the disinfectant can influence the performance of your instrument if it comes into contact with the electronics!

The following procedure should be used to disinfect the instrument:

1. Wear protective powder-free gloves, protective glasses and protective clothing.
2. Prepare an autoclave bag for all disposables used during the disinfection procedure, label it with autoclave tape and put it in the autoclave or follow the procedure defined in chapter 8.9.3 Disposal of Operating Material.
3. Prime the liquid system with disinfectant. Perform the Rinse - Night procedure with disinfectant solution and stop the procedure after five hours.
4. Switch off the instrument and disconnect the instrument from the mains power supply.
5. Disconnect the instrument from any accessories that are used for example: Liquid Level Detection System, computer, etc. Accessories that should be shipped together with the instrument have to be included in the disinfection procedure.
6. Carefully spray the disinfectant solution (or use a disposable soft tissue paper towel soaked in the disinfectant) on all outer surfaces of the instrument.
7. After a minimum contact time of 10 minutes, repeat step 6 of this procedure.
8. Wipe dry the outer surfaces of the instrument.

8. Maintenance and Cleaning

9. Pack the instrument and its accessories.
10. Wash your hands with a mild detergent and then disinfect them.
11. Complete a disinfection certificate and attach it to the outside of the box so that it is clearly visible. (See below for an example of the disinfection certificate).

Disinfection Certificate

A disinfection certificate label **MUST** be completed and attached to the top of the package (**visible from the outside of the shipping container!**) in which the instrument is returned, before shipping it to the service center for service or repair.

The instrument **MUST** be disinfected at the operating authority's site.

The disinfection procedure must be performed in a well-ventilated room by authorized and trained personnel wearing disposable powder-free gloves, protective glasses and protective clothing.

The disinfection procedure should be performed according to national, regional, and local regulations.

<p>I declare that the instrument in this package has been decontaminated or disinfected to remove or inactivate any biological material, which could be dangerous to service personnel, or that it has never been exposed to any hazardous biological material.</p> <p>Contact person.....</p> <p>Company:.....</p> <p>Function:</p> <p>Phone/Fax:.....</p> <p>E-mail:</p> <p>Date of decontamination:</p> <p>Method of decontamination applied:</p> <p>.....</p> <p>Date:.....</p> <p>Signature:.....</p>
--

8.9 Disposal of Instrument

8.9.1 Introduction

This chapter gives instructions on how to lawfully dispose of waste material accumulating in connection with the HYDROFLEX.



Caution
Observe all federal, state and local environmental regulations.



ATTENTION

Directive 2002/96/EC on waste electrical and electronic equipment (WEEE)
Negative environmental impacts associated with the treatment of
electrical and electronic equipment waste

- Do not treat electrical and electronic equipment as unsorted municipal waste.
- Collect waste from electrical and electronic equipment separately.

8.9.2 Disposal of Packing Material

According to Directive 94/62/EC on packaging and packaging waste, the manufacturer is responsible for the disposal of packing material.

Returning Packing Material

If you do not intend to keep the packing material for future use, e.g. for transport and storage purposes:

Return the packaging of the product, spare parts and options via the field service engineer to the manufacturer.

8. Maintenance and Cleaning

8.9.3 Disposal of Operating Material



WARNING
 CHEMICAL AND BIOLOGICAL HAZARDS CAN BE ASSOCIATED WITH THE WASTE MATERIAL (MICROPLATE) OF PROCESSES RUN ON THE HYDROFLEX.
 TREAT THE USED MICROPLATE, WASTE BOTTLE, PRIME TRAY ON THE PLATE CARRIER, DISPOSABLES AND ALL SUBSTANCES USED, IN ACCORDANCE WITH GOOD LABORATORY PRACTICE GUIDELINES.
 INQUIRE ABOUT APPROPRIATE COLLECTING POINTS AND APPROVED METHODS OF DISPOSAL IN YOUR COUNTRY, STATE OR REGION.

8.9.4 Disposal of the HYDROFLEX

Please contact your local Tecan service representative before disposing of the instrument.



Caution
 Always disinfect the instrument before disposal.

Pollution degree 2 (IEC/EN 61010-1)
Method of Disposal Contaminated Waste



WARNING
 DEPENDING ON THE APPLICATIONS, PARTS OF THE HYDROFLEX MAY HAVE BEEN IN CONTACT WITH BIOHAZARDOUS MATERIAL.

- MAKE SURE TO TREAT THIS MATERIAL ACCORDING TO THE APPLICABLE SAFETY STANDARDS AND REGULATIONS.
- ALWAYS DECONTAMINATE ALL PARTS BEFORE DISPOSAL (I.E. CLEAN AND DISINFECT).

9. Trouble Shooting and Error Messages

9.1 Errors

The following errors can occur, which will not yield an error message from the standard instrument's firmware:

Error Description	Possible Causes	See Chapter
Display and LED dark	Fuse is defective.	Contact your local Service Representative
No or incorrect dispensing	Dispensing needles blocked.	8.3.2 Cleaning the Liquid System
No or incorrect aspirating	Aspirating needles blocked.	8.3.2 Cleaning the Liquid System

9.2 Error Messages

9.2.1 Standard Instrument: Error Messages

Plate Error

If the plate sensor does not recognize the plate or no plate is inserted on the plate carrier, the following message is displayed:



Press **OK** and insert the plate correctly on the plate carrier

Program Too Big Error

If the program has been defined with more than 60 process steps (each cycle is worth 2 steps), the following message is displayed:

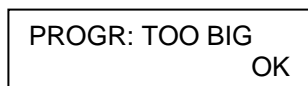

Press **OK** and define a program with less than 60 process steps.

9. Trouble Shooting and Error Messages

Transport Error

If the instrument cannot move the plate carrier, the following message is displayed:

INIT ERROR	OK
------------	----

Press **OK** to remove the error message and the instrument returns to the standby mode.

Check that the plate carrier is correctly inserted and that the plate carrier system is clear.

Manifold Arm Error

If the manifold arm cannot be lowered correctly due to obstruction of its normal movement, the following message is displayed:

MANIFOLD HEAD UP	EXIT
------------------	------

Press **EXIT** to remove the error message and to return to the standby mode.

Check that the microplate is correctly inserted into the plate carrier.

Check that the manifold arm is not blocked.

Check if the needles are catching on the side of the microplate; use the Settings menu to adjust the positions for that particular type of microplate.

Sensor Defect Error

The following message error is displayed when the dispensing pump or the dispensing sensor is defective.

SENSOR DEFECT	OK
---------------	----

Press **OK** to remove the error message and to return to the standby mode.

Make sure that drip mode has not been selected using distilled water. Change the program parameters.

If the program parameters are correct and the error continues, call the service technician.

9.2.2 Liquid Level Detection: Error Messages

Waste Bottle Full at Start

If the waste bottle is full, the following message is displayed:

```
LLD ERROR
                OK
```

Press **OK** to remove the message and return to the start and the following message is displayed:

```
START
< >      OK
```

Empty the waste bottle and restart the program.

Waste Bottle Full during Procedure

If the waste bottle becomes full during the washing procedure, the instrument will beep; however, no error message is displayed during or after the instrument has completed the washing procedure.



Caution
The instrument does not stop a procedure when the waste bottle becomes full.



WARNING
Waste Bottle – Foaming
THE LIQUID LEVEL SENSOR IS UNABLE TO DETECT FOAM; THEREFORE IT IS IMPORTANT THAT THE WASTE BOTTLE IS EMPTIED AS SOON AS THE FOAM LEVEL HAS REACHED THE MAXIMUM FILLING LEVEL INDICATED ON THE WASTE BOTTLE.

**WARNING****WASTE BOTTLE – FOAMING**

WHEN USING WASH BUFFERS THAT SHOW A STRONG TENDENCY OF FOAMING, EMPTY THE WASTE BOTTLE AS SOON AS THE FOAM-LEVEL HAS REACHED THE MAXIMUM FILLING LEVEL INDICATED ON THE WASTE BOTTLE. ADDITIONALLY, ADD A COMMERCIALY AVAILABLE ANTI-FOAMING AGENT (SUCH AS SILICONE OIL) TO THE EMPTY WASTE BOTTLE TO REDUCE FOAMING.

IF FOAMING CONTINUES TO BE A PROBLEM, WE RECOMMEND SWITCHING TO A LARGER WASTE BOTTLE (NOT PROVIDED WITH THE HYDROFLEX) AND ADDITIONALLY INCREASE THE CONCENTRATION OF ANTI-FOAMING AGENT IN THE WASTE BOTTLE. TO HELP FACILITATE BREAKDOWN OF THE FOAM IN THE WASTE BOTTLE, CAREFULLY SWIRL THE WASTE BOTTLE FROM TIME-TO-TIME TO IMPROVE MIXING BETWEEN FOAM LAYER AND ANTI-FOAMING AGENT.

REFILL ANTI-FOAMING AGENT AFTER EMPTYING WASTE BOTTLE. FOR EXAMPLE, WHEN USING THE WACKER ANTI-FOAM EMULSION SE47 (WACKER ARTICLE CODE 21640582), THE RECOMMENDED CONCENTRATION IS 1ML OF ANTIFOAMING AGENT FOR 1 LITER OF WASTE SOLUTION.

FOR ANTIFOAMING AGENTS FROM OTHER MANUFACTURERS, USE CONCENTRATIONS AS RECOMMENDED BY CORRESPONDING MANUFACTURERS.

Liquid Bottle Empty

If the liquid bottle is empty before a program is started, the following message is displayed:

LLD ERROR
OK

Fill the liquid bottle and press OK to remove the message and start the program again.

Index

Numbers refer to pages.

A

Area of Application	15
Aspirate.....	44
Aspirating Modes.....	35
Aspiration Position Diagrams	44

C

Cleaning.....	59
Cover and Display.....	64
Liquid System	64
Procedures.....	64
Waste Bottles.....	65
Clear Program	49
Connection Diagram.....	28

D

Define/Edit Menu	11, 33, 36, 43
Disinfection	74
Certificate	76
Procedure	75
Dispense.....	45
Dispense Accuracy.....	55
Result interpretation.....	57
Dispensing Position Diagrams	45
Disposal	
HYDROFLEX.....	78
Operating Material	78
Packing Material	77
Drip Mode	36

E

Edit LLD Channel	52
Edit Plates.....	51
End of Operation	38
Error	
Liquid Bottle Empty.....	82
Manifold Arm.....	80
Plate.....	79
Program Too Big.....	79
Transport.....	80
Error Messages	79
Liquid Level Detection Option.....	81
Standard Instrument	79
Errors.....	79

F

Firmware	30
Firmware Menus.....	30

I

Installation Procedure.....	27
Installing the Manifold.....	71
Instrument	
Description	19
Disinfection	74
Disposal	77
Firmware.....	30
Safety.....	11
Specifications.....	17
Switching on	29
Instrument Options	22
Intended Use	15

L

Liquid Level Detection (LLD).....	22
Fitting and Connecting.....	22
Liquid or Foam Spills.....	66
Liquid System Diagram	22

M

Maintenance.....	59
Daily.....	67
Every Six Months.....	68
Weekly.....	67
Yearly.....	68
Manifold	
General Description	69
Replacing.....	68
Microplate Requirements	23

O

Operating Instructions	33
Options Submenu.....	52

P

Packing Material	
Disposal of	77
Returning	77
Performance Testing.....	55
Plate Carrier	

Index

Replacing	73	Rinse Night	59, 61
Power Requirements	25	Rinse Procedure	
Preventive Maintenance Plan	67	Day	59
Priming	62	Night	59
Priming Procedure	63	Rinsing	59
Procedures Menu	53	S	
Process Step		Safety	11
Aspirate	44	Settings Menu	51
Dispense	45	Show Program	48
Soak	47	Soak	47
User Prompt	47	Spills	66
Wash	46	Starting a Program	42
Program Menu	41	T	
Q		Trouble Shooting and Error Messages	79
QC Procedure		U	
Troubleshooting	57	Unpacking and Inspection	
QCASP	56	Checklist	26
QCDISP	56	Unpacking and Inspection	25
R		User Profile	16
Rear Panel Connections	21	User Prompt	47
Removing the Manifold	70	W	
Requirements		Wash	46
Power	25	Wash Modes	34
Working Area	25	Wash Procedure	
Residual Volume	55	Performing	33
Residual Volume Check	56	Washing Positions	34
Result interpretation	57	Working Area Requirements	25
Rinse Day	59, 60		
Rinse Menu	59		

Declaration of Conformity

We, TECAN Austria GmbH herewith declare under our sole responsibility that the product identified as:

Product Type: Microplate Washer
Model Designation: *HYDROFLEX*
Article Numbers: 30087531, 30087532, 30087533, 30087534, 30087535

Address: Tecan Austria GmbH
Untersbergstr. 1A
A-5082 Grödig, Austria

is in conformity with the provisions of the following EC Directive(s) when installed in accordance with the installation instructions contained in the product documentation:

2004/108/EC – EMC Directive
2006/42/EC - Machinery Directive

and that the standards referenced below were taken in consideration:

EN 61010-1:2001/AC:2002	Safety requirements for electrical equipment for measurement, control, and laboratory use -- Part 1: General requirements
EN 61010-2-081:2002 /A1:2003	Safety requirements for electrical equipment for measurement, control, and laboratory use -- Part 2-081: Particular requirements for automatic and semi-automatic laboratory equipment for analysis and other purposes
EN 61326-1:2006	Electrical Equipment for Measurement, Control, and Laboratory Use - EMC Requirements -- Part 1: General requirements
EN ISO 12100:2010	Safety of machinery - General principles for design - Risk assessment and risk reduction

Year of CE-marking: 2013

These *Instructions for Use* and the included *Declaration of Conformity* are valid for all HYDROFLEX instruments with the article numbers listed above. The model designation varies depending on the specific model with different article number.