Digital Sonifier®
Models 250 & 450
User's Manual

EDP 100-214-239
Rev. A

BRANSON Ultrasonics Corporation
41 Eagle Road
Danbury, Connecticut 06813-1961 U.S.A.
(203) 796-0400

Manual Change Information

At Branson, we strive to maintain our position as the leader in ultrasonics plastics joining, cleaning and related technologies by continually improving the designs, circuits and components in our equipment. These improvements are incorporated as soon as they are developed and thoroughly tested.

Information concerning any improvements will be added to the appropriate technical documentation at its next revision and printing. Therefore, when requesting service assistance for specific units, note the Release information found on the cover of this document, and refer to the printing date which appears in the lower right corner of this page.

Patents and Copyright

Copyright © 1998 by Branson Ultrasonics Corporation, Danbury, Connecticut, U.S.A.
All rights reserved.

Manual part number: EDP 100-214-239 Rev. A, printed February 2001.

Branson Ultrasonics Corporation equipment is manufactured under one or more of the following U. S. Patents:

4,249,986; 4,315,181; 4,363,992; 4,551,690; 4,651,043; 4,786,356; 4,973,876; 5,095,188;
5,435,863.

Note: Sonifier[®] is a registered trademark of Branson Ultrasonics Corporation, Danbury, Connecticut, U.S.A. Other trademarks and service marks respectfully mentioned herein are held by their respective owners.

Digital Sonifier[®]

User's Manual

Forward

Congratulations on your choice of a Branson Ultrasonics Corporation system!

The Branson Digital Sonifier[®] system is the newest generation of product using this sophisticated technology for a variety of customer applications. This manual should be kept with the system.

Thank you for choosing a Branson product!

Introduction to this manual

This manual is arranged into seven structured chapters which will help you find the information you may need to know to safely handle, install, set up, program, operate, and/or maintain this product. Additional information is provided in several Appendix chapters.

In the event you require additional assistance or information, please contact our Product Support department (see *'How to Contact Branson'* on page 1-5 for information on how to contact us) or your local Branson representative.

For Your Notes

1 Safety and Support

1.1	Safety Considerations	1-1
1.2	General Precautions	1-2
1.3	Regulatory Compliance	1-3
1.4	Warranty	1-4
1.5	How to Contact Branson	1-5

1.1 Safety Considerations



CAUTION

The following safety considerations should be observed when operating the Digital Sonifier®:

- Make sure that the equipment is properly grounded. **DO NOT** operate if it is not.
- The unit is equipped with a three-conductor cord and three-prong grounding-type plug, and must be plugged into a three-prong grounding-type wall receptacle. **DO NOT** under any circumstances remove the power cord ground prong.
- **DO NOT** operate the equipment with the cover removed. High voltage is present within the equipment when connected to plant wiring.
- **DO NOT** turn on the ultrasonics without the converter and horn attached.
- **DO NOT** touch the horn or tip when ultrasonics are active. When handling, removing, or attaching a horn or tip, be sure that the ON/OFF switch is set to OFF. Touching the horn or tip while the unit is on can result in serious personal injury.
- **DO NOT** allow the horn or microtip to contact lab stands, beakers, or similar objects. Horn/microtip failure may result.
- **DO NOT** operate the equipment at more than 70% amplitude when using a microtip horn.
- Establish a standard of operation and test equipment periodically.

1.2 General Precautions

1.2.1 Intended Use of the System

The 250/450 Digital Sonifiers can be used to disrupt cells, bacteria, spores, or tissue, and are ideal for initiating and accelerating chemical, biochemical, and physical reactions, and for de-gassing liquids. With the Digital Sonifier, you can prepare an emulsion to 0.01 micron, homogenize immiscible liquids, polymerize some materials, and depolymerize others.

1.2.2 Safety Measures and Guards

This manual contains operation instructions for the Digital Sonifier cell disruptor Models 250 and 450. It contains information essential to the proper use and care of this equipment. The manual contains notes, warnings, and cautions. These are described as follows:



NOTE

Provides information that the reader should follow to prevent inconvenience.



CAUTION

Advises the user of a hazard that can cause equipment damage or personal injury.



WARNING

Alerts the reader to a hazard that can result in severe personal injury. Do NOT disregard a WARNING.

1.2.3 Safe Operation

Setup and Operation instructions are found in Chapter 6 of this manual.

For safe operation, please ensure that all people using this equipment follow those instructions and observe all CAUTION and WARNING notices.

1. Make sure that the equipment is properly grounded. DO NOT operate if it is not.

2. The unit is equipped with a three-conductor cord and three-prong grounding type plug and must be plugged into a three-prong grounded receptacle. DO NOT under any circumstances remove the power cord ground prong, or use a plug 'Adapter'.
3. DO NOT operate equipment with the cover removed. High voltage is present within the equipment when connected to plant wiring.
4. Do not allow the horn or microtip to contact lab stands, beakers, etc. or horn/microtip failure may result.
5. Establish a standard of operation and periodically test the equipment, as described in *Ultrasonic Test* on page 4-17.

Although the Digital Sonifier operates outside the normal range of human hearing, some applications can create audible noise above 85dB. Noise can occur, for example, when the device touches a solid material, or when its operation causes nearby objects in the lab to vibrate. If an uncomfortable level of noise is present, the operator should wear ear protection for safe operation.

Appropriate eye protection should be worn when operating the Digital Sonifier, to prevent possible splash injury originating in the solution.

**WARNING**

Never touch the horn or tip when ultrasonics are active. Touching the horn or tip while the unit is on can result in serious injury. When you handle, remove, or attach a horn or tip, always make sure that the ON/OFF switch is OFF.

1.2.4 Setting Up the Workplace

The unit should be positioned away from radiators and heating vents. A fan inside the unit maintains a safe operating temperature in the power supply by circulating air over the components. Therefore, place the unit so that the air intake on the bottom of the power supply is not blocked. Periodically, unplug the unit and clean the air intake underneath the power supply to ensure that dust or dirt is not restricting the flow of air. If the Digital Sonifier is to be used for remote operation, ensure that the unit is situated within full view of the operator, to prevent injury or equipment damage through an accidental or automatic start-up.

1.3 Regulatory Compliance

The Digital Sonifier is designed for compliance with the following regulatory guidelines.

- European norms EN-61010-1, EN55011, EN50082-1, ENV50140, ENV50141
- IEC 529 (IP-65 water resistant for Membrane Keypad)

The Digital Sonifier is CE compliant.

1.3 Warranty

Refer to the "Terms and Conditions of Sale" found on the back of your Invoice for information about the product Warranty issued of your Branson products. If you have any questions, please contact your Branson representative. The product warranty information is summarized below.

WARRANTY

When used in accordance with written instructions and under normal operating conditions, Branson Ultrasonics Corp. equipment is guaranteed to be free of defects in MATERIAL and WORKMANSHIP for two (2) years from the date of original delivery by BRANSON or by an authorized representative. Any unit which proves defective during the stated period will be repaired free of charge or replaced at the sole discretion of Branson Ultrasonic S.A., 9, ch. Faubourg-de-Cruseilles, CH-1227 Carouge/Geneva or an authorized repair station as advised by BRANSON, provided the defective unit is returned properly packed with all transportation charges prepaid. A limited warranty as specified may apply to certain components of the equipment.

WARRANTY EXCEPTIONS

This warranty shall not apply to equipment subjected to misuse, improper installation, alteration, neglect, accident or improper repair.

This warranty is limited to the original purchaser and is not transferable.

Horns and tips fabricated by Branson for use in equipment described in this manual are manufactured to exacting parameters. Using altered or modified horns and tips or horns and tips otherwise unqualified by Branson can produce undue stresses that may damage the equipment. Equipment failures resulting from using unqualified horns and tips are not covered by the Branson warranty.

Microtips are designed to give maximum mechanical energy output. Since they operate close to the stress limits of titanium, Branson cannot guarantee microtips against failure.

CONTACT YOUR BRANSON REPRESENTATIVE OR BRANSON ULTRASONICS CORPORATION, DANBURY, CONNECTICUT, SHOULD YOU HAVE ANY QUESTIONS CONCERNING HORN QUALIFICATION.

1.4 How to Contact Branson

The mailing address and telephone information for Branson is as follows:

Branson Ultrasonic SA
9, chemin Faubourg-de-Cruseilles / P.O. Box 1031
CH-1227 Carouge/Geneva
Phone : +41-22-304 83 58 Fax: +41-22-304 83 59

Tell the operator which product you have and which person or department you need. If after hours, please leave a voice message with your name and return telephone number.

1.4.1 Before Calling Branson for Assistance

This manual provides information for troubleshooting and resolving problems that could occur with the equipment (see Chapter 7). If you still require assistance, Branson Product Support is here to help you. The following questionnaire lists the common questions you will be asked when you contact the Product Support department, to help identify the problem.

Before calling, determine the following information:

1. Your company name and location.
2. Your return telephone number.
3. Have your manual with you. If troubleshooting a problem, refer to Chapter 7.
4. Know your equipment model and serial numbers (found on a gray data label on the units). Information about the Horn (part number, gain, etc.) or other tooling may be etched into the tooling. Software- or-firmware based systems may provide a BOS or software version number, which may be required. (The Digital Sonifier provides the firmware information on the start-up screen.)
5. What tooling (horn) and booster are being used?
6. What are the setup parameters and mode?
7. Is your equipment in an automated system? If so, what is supplying the "start" signal?
8. Describe the problem; provide as much detail as possible. For example, is the problem intermittent? How often does it occur? How long before it occurs if you are just powering up? If an error is occurring, which error (give error number or name)?
9. List the steps you have already taken.
10. What is your application, including the materials being processed?
11. Have a list of service or spare parts you have on hand (tips, horns, etc.)

Returning Equipment for Repair

Before sending equipment for repair, provide as much information with the equipment to help determine the problem with the system. Fill in any details below or on a separate sheet.

1. Describe the problem; provide as much detail as possible. For example, is this a new problem? Is the problem intermittent? How often does it occur? How long before it occurs if you are just powering up?

2. Is your equipment in an automated system? If so, is the problem related to Start/Stop control, or interaction with PLC's or other devices, etc.?

3. If the problem is with an external signal or output, which one?

If known, include plug/pin # (e.g., P29, pin #3):

4. What are the setup parameters?

5. What is your application (e.g., continuous, pulse, temperature, etc.)?

6. Name and phone number of the person most familiar with the problem:

7. Notify the Branson office prior to shipping the equipment.



NOTE

To Return Equipment to Branson, you must first obtain an **RGA number** from a Branson representative, or the shipment may be delayed or refused.

8. For equipment not covered by warranty, include a purchase order for the repair costs to avoid delay.
9. Pack carefully in original packing material to avoid damage in shipment.
10. Return general repairs by any desired method. Send priority repairs by air freight.
11. Prepay the transportation charges FOB Danbury, Connecticut, U.S.A.

Notes:

Returning Equipment for Repair (to Geneva facility)



NOTE

To return equipment to Branson, you must first obtain an **RGA number** from a Branson representative, or the shipment may be delayed or refused.

If you are returning equipment to Branson for repair, you must first call the Danbury Repair department to obtain a Returned Goods Authorization (RGA) number. (If you request it, the repair department will fax a Returned Goods Authorization form to fill out and return with your equipment.)

Branson Ultrasonic SA
9, chemin Faubourg-de-Cruseilles / P.O. Box 1031
CH-1227 Carouge/Geneva
Phone : +41-22-304 83 58 Fax: +41-22-304 83 59

- Provide as much information as possible that will help identify the need for repair.
- Carefully pack the equipment in original packing cartons.
- Clearly label all shipping cartons with the RGA number on the outside of cartons as well as on your packing slip, along with the reason for return.
- Return general repairs by any convenient method. Send priority repairs by air freight.
- You must prepay the transportation charges FOB Danbury, Connecticut, U.S.A.

Obtaining Replacement Parts

You can reach Branson Parts Store at the following telephone numbers:

Branson Part Store
direct telephone number: +41-22-304 83 58
fax number: +41-22-304 83 59

Many parts can be shipped the same day if ordered before 2:30 p.m., Eastern time.

A parts list is found in Section 7 of this manual, listing descriptions and EDP part numbers. If you need replacement parts, coordinate the following with your purchasing agent:

- Purchase order number
- 'Ship to' information
- 'Bill to' information
- Shipping instructions (air freight, truck, etc.)
- Any special instructions (for example, "Hold at the airport and call"). Be sure to give a name and phone number
- Contact name information

For Your Notes

2 Introduction to the Digital Sonifier

2.1 Overview of Digital Sonifier	2-1
2.2 Controls and Commands	2-3
2.3 System Features	2-9

2.1 Overview of Digital Sonifier

The 250/450 Digital Sonifier is often used by laboratory personnel in the medical and chemical process fields. The system consists of three core elements: the power supply, the controls, and the converter and horn. The system can interface with customer equipment including a remote computer or terminal, dot matrix printer, temperature probe, and User I/O.

Figure 2.1 Digital Sonifier

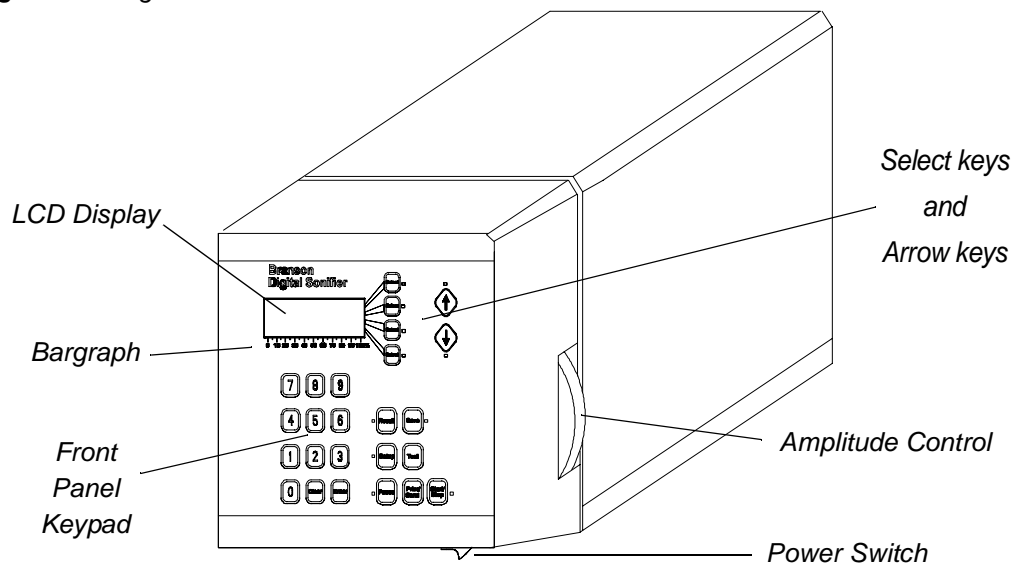

The 250 and 450 Digital Sonifiers differ only in their output power ratings, measured when the output control is at maximum setting. The 250's maximum available output power is up to 200 watts; the 450's maximum available output power is up to 400 watts.

The digital controls on the Digital Sonifier allow for accuracy and repeatability of control settings. You enter application parameters into the system either through the keypad on the front panel of the unit, or remotely through a computer keyboard, and can save up to twenty (20) sets of preset control parameters. You can view operating parameters through the twenty-character, four-line LCD display on the unit control panel and on a remote terminal if one is connected. At System Setup, you can select a language for the display: English, German, French, Italian, or Spanish.

The Digital Sonifier's power supply converts AC line voltage to 20kHz electrical energy. This high-frequency electrical energy is fed to a converter where it is converted to mechanical vibrations. The heart of the converter is a lead zirconate titanate electrostrictive element which, when subjected to an alternating voltage, expands and contracts. The converter vibrates in a longitudinal direction and transmits this motion to the horn tip immersed in the solution, which causes cavitation. The implosion of microscopic cavities in the solution results, causing the molecules in the medium to become intensely agitated. The ultrasonic vibrations transmitted through the horn can also be applied directly to a solid workpiece, such as tissue, through a variety of different tips that can be attached to the horn.

The Digital Sonifier is a constant amplitude device. As the load or pressure on the horn face increases, the power supply develops more power to maintain the amplitude for any given output control setting. When the horn is operated in air, it is subjected to minimum pressure, and minimum power is required to maintain amplitude.

The load increases when the horn is immersed in a liquid; the more viscous the liquid, the higher the load and the more power developed. If a flow-through cell that can be pressurized is used, thereby increasing pressure on the horn, even more power is developed. For any given application, more power results when a horn of higher amplitude or larger radiating surface is used, or when any horn is driven at higher amplitude by increasing the amplitude.

By setting various operation parameters, you can precisely control the way in which ultrasonics are applied to the sample. You can:

- Specify the time duration of the experiment
- Adjust the amplitude setting between 10% and 100% of maximum amplitude (microtip 70% maximum)
- Prevent excessive temperature increase in the sample by setting ultrasonics to operate in Pulse mode or in Pulse/Pause mode
- Bring a sample to a desired temperature and hold it there, varying by only a few degrees, for a desired duration using the Pulse/Pause mode
- Set the maximum allowable temperature in the sample, so that ultrasonics will stop automatically when the specified temperature is reached

2.2 Controls and Commands

This section describes the controls and commands that you use to operate the Digital Sonifier. A detailed description of how and when to use each front panel control, the valid formats for the data that you enter, and the response you receive from the system when you use each of these controls is provided in *Chapter 6, Operations*.

The Digital Sonifier is equipped with a keypad and LCD display on the front panel of the unit. With the keypad, you can set functional modes of operation and input digital parameters. Availability of the various functions depends on the mode or state of the system. If you attempt to use a function that is not available, you will be alerted by a beep.

Figure 2.2 Digital Sonifier front-panel Controls

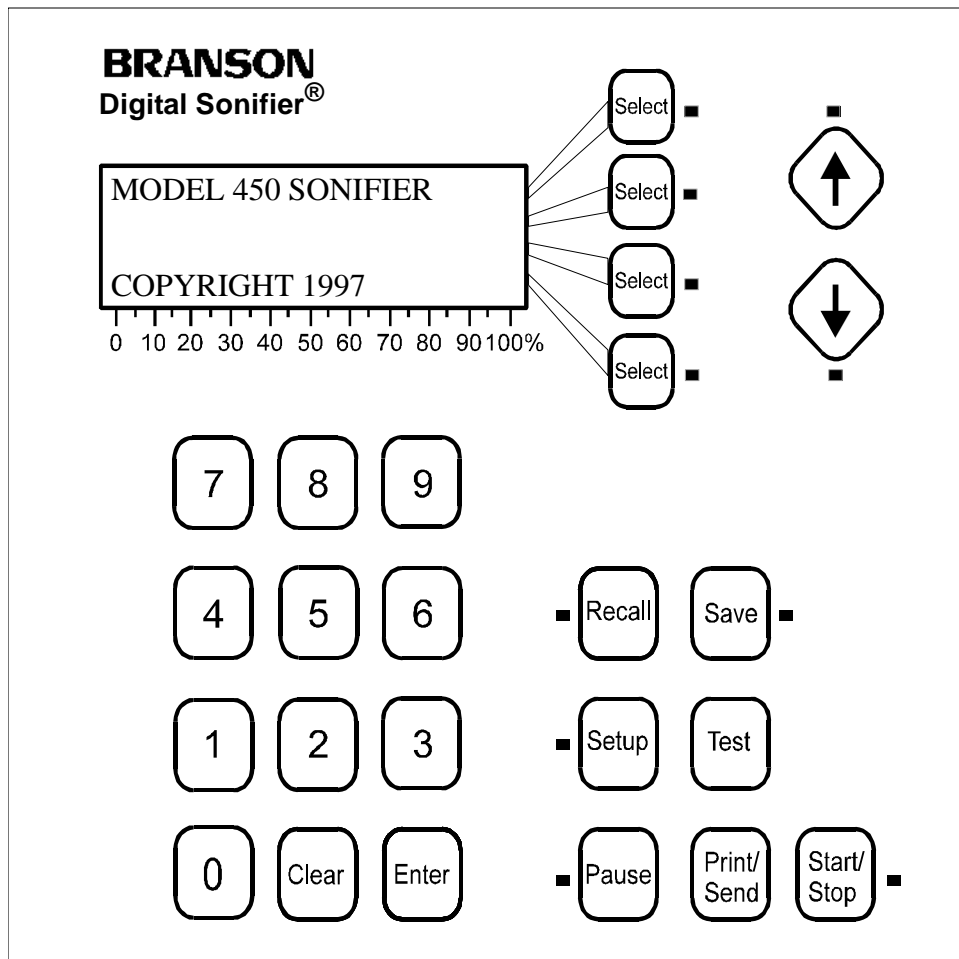

Operation of the Digital Sonifier can also be controlled through a remote computer terminal or User I/O device. You always have the ability to halt operation, whether control is direct or remote.

Each key on the front panel of the unit, except for the numeric keys, Print and Test, has an LED indicator near it. When the key is active, the LED is turned on. Some of the keys on the Digital Sonifier keypad have equivalent commands (preceded by !) that can be entered through the remote terminal's keyboard.

- *Section 2.2.1, Digital Sonifier Keypad Description*, beginning on page 2-4, describes each key on the Digital Sonifier keypad and identifies its equivalent remote terminal command (preceded by an ! exclamation point) if applicable.
- *Section 2.2.2, Remote Terminal Commands*, beginning on page 2-7, provides a detailed description of all remote terminal commands. *Section 2.2.3, Back Panel Connections*, on page 2-8, describes the back panel of the unit.

2.2.1 Digital Sonifier Keypad Description

LCD Display

The front panel is equipped with a four-line, 20-character display screen where menus, parameter options, messages, and warnings are displayed. If the data being displayed has more than one page, you can navigate up and down in the display by pressing the Page Up and Page Down arrow keys.

The first page of a typical Ready display.

If you wish to see the second page, press the Down Arrow button.

```

PRESET ID#16
TIME= 0:12:52 hr/m/s
MAX. TEMP= 104.3 °F
AMPLITUDE= 43 %
    
```



The second page of a Ready display.

If you wish to see the first page, press the Up Arrow button.

```

PULSE ON= 2.1 SEC
PULSE OFF= 1.6 SEC
PULSE TEMP= ___._ F
PROBE TEMP= 67.6 °C
    
```



Line Select Keys

There are four Line Select keys to the right of the display. When a Line Select key is active, the LED next to it is turned on. You can press a Line Select key to:

- Select a line in the Parameter Entry menu display for a parameter entry.
- Toggle values in a parameter or System Setup submenus (for example, Yes or No).
- Select an item from the options available when the system issues a warning/error message.

Once a Line Select key is pressed, its LED is turned off. When you begin entering a value for a parameter you selected with a Line Select key, all the other Line Select keys become inactive and their LEDs are also turned off until you complete the parameter entry. If you have selected a line but have not begun to enter a value, the other Line Select keys remain active, and you can select another line on which to enter a parameter value.

Page Up and Page Down Keys

The Page Up and Page Down arrow keys are active when you are displaying a menu that has more than one page. You can use the Page Up and Page Down keys to move up and down in the menu. If there are more menu items above the page you are viewing, the Page Up arrow is active and its LED is turned on. If there are menu items below the page you are viewing, the Page Down arrow is active and its LED is turned on.

Start/Stop Key (!ON and !OFF Commands)

The Start/Stop key and !ON command are active during Parameter Entry mode (except when you are changing a parameter value) and during the Sonics Active displays. When you press the Start/Stop key or type in the !ON Command, the experiment is executed, and the LED next to the key is turned on. When you press the Start/Stop key again or type in the !OFF command, the experiment is stopped, and the LED is turned off.

Setup Key

The Setup key is active during Parameter Entry mode (except while you are changing a parameter value) and while you are viewing the Setup Menu. When you press the Setup key, the first page of the Setup menu is displayed and the Setup key's LED is turned on. When you press the Setup key again, the Setup menu is closed and its LED is turned off.

Test Key (!TS Command)

The Test key and the !TS command are active when the system is in the Ready state. When you press the Test key or type in the !TS command, ultrasonics are enabled for two seconds. To turn on ultrasonics for another two seconds, you can press the Test key or type in the !TS command again.

Pause Key (!H Command)

The Pause key and the !H command are active only when the unit is operating. When you press the Pause key or type in the !H command, operation of the unit halts and the Pause key's LED is turned on. When you press the Pause key or type in the !H command again, the unit resumes operation, and the LED is turned off.

Recall Key (!R Command)

The Recall key and the !R command are active only during Parameter Entry mode, except when you are changing a parameter value. When you press the Recall key or type in the !R command, a message is displayed and the LED is turned on. Refer to *Section 6.6, Save and Recall Presets*, on page 6-40, for information on how to save and recall presets.

Save Key (!SV Command)

The Save key and the !SV command are active during Parameter Entry mode, except when you are changing a parameter value. When you press the Save key or type in the !SV command, a message is displayed and the LED is turned on. Refer to *Section 6.6, Save and Recall Presets*, on page 6-40, for information on how to save and recall presets.

Print/Send Key (!P and !S Commands)

The Print/Send key and the !P and !S commands are only active after a test or experiment has been executed, and before another test or experiment begins or the Setup menu parameters are changed. For this function to operate, a printer, a remote terminal, or both must be enabled. When you press the Print/Send key, report data is sent to the remote terminal and to the printer. Refer to *Section 6.7, Printing/Sending Reports*, on page 6-41, for a description of the data that is sent to the terminal and printer.

Enter Key

You can press the Enter key on the Digital Sonifier or on the computer keyboard to:

- Cause the system to accept a modified parameter value
- Clear an error/warning message.
- Store a Setup parameter value

If you have entered a modified parameter value, the system checks the value for validity and format. If the value you entered is valid, the value is accepted, and it replaces the old value. The original value is lost and cannot be recovered unless it has been stored under a preset ID number. If the modified value is invalid, an appropriate error message is displayed.

Clear Key

The Clear key on the Digital Sonifier is active at any time when a parameter can be changed. If you press the Clear key when you are modifying a parameter value, the entry field becomes blank, and the cursor is moved to the least significant position. If you press the Enter key while the entry field is blank, no value is stored for the parameter.

Numeric Keys

The keys for 1 through 9 and 0 are active at any time when a parameter has been selected to be changed.

2.2.2 Remote Terminal Commands

This table describes the remote terminal commands and their functions. All of the remote terminal commands must be preceded by an exclamation point. Refer to *Chapter 6, Operations*, for a description of the system's response to each of these commands and the actions you should take at each response.

Table 2-1: Remote Terminal Commands

Send this command...	When you want to...
!T	Enter the TIME duration value.
!MT	Enter the MAXIMUM TEMPERATURE value.
!PO	Enter the PULSE ON time value.
!POF	Enter the PULSE OFF time value.
!PPT	Enter the Pulse Temperature value.
!S	Send all report data to the remote terminal.
!P	Print all report data, if a printer is enabled.
!R	Recall a particular preset.
!H	Pause operation of the Digital Sonifier until you send another !H command.
!MT	Enter the Maximum Temperature value.
!TS	Test the system for two seconds.
!ON	Start the experiment.
!OFF	Stop the experiment.
!KL	Lock out the keypad on the front panel. The keypad is enabled again if you send another !KL command, or if you turn the power off on the Digital Sonifier and then turn it on.
!SV	Save the parameters entered.
!RP	View all the test or experiment parameter values.

2.2.3 Back Panel Connections

Figure 2.3 Back Panel of Digital Sonifier

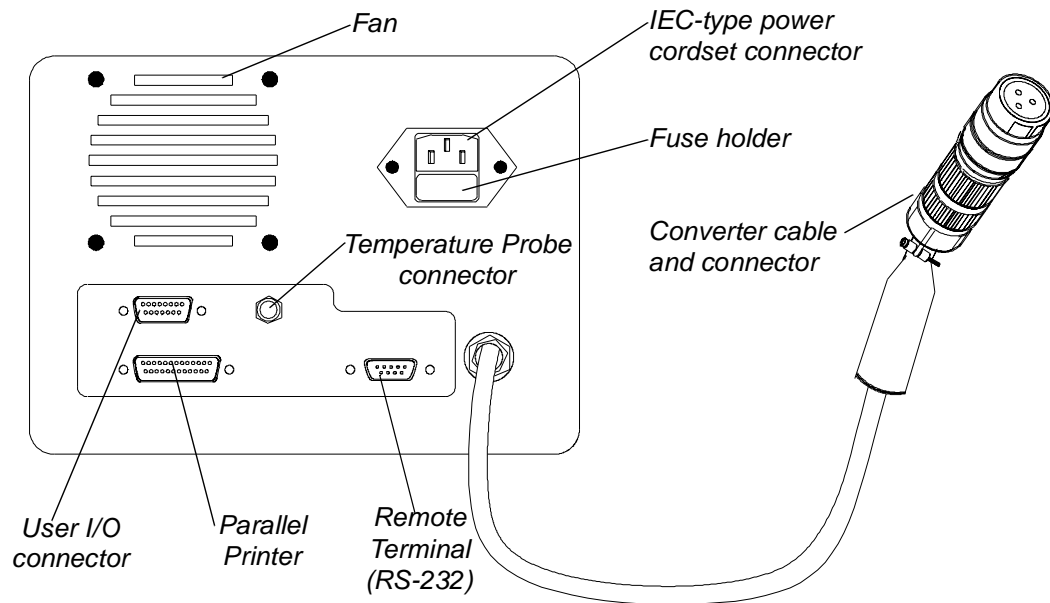

The back panel of the Digital Sonifier is equipped with:

- An IEC-type power cord connection for connecting the power supply to a grounded electrical outlet.
- A fuse holder for access to a replaceable 5x20mm protective fuse. The fuse is a glass slow-blow type (refer to the data tag for the fuse rating).
- A converter cable with connector to connect the power supply to the Converter.
- An RS-232 connector (female DB9) for connecting a remote computer terminal to the unit. This connection requires a cable with a 9-pin male connector. Serial ASCII data is transferred through this connection at a user-selectable baud rate of 1200, 2400, 9600, or 19200 bps with 8 data bits, 1 stop bit, and no parity. RX, TX, and Signal Ground are supported.
- A parallel printer connector (female DB25) requiring a 25-pin male connector. During System Setup, you can select the dot-matrix printer choices from Panasonic, Epson, or IBM.
- A User I/O connector (female DB15) requires a cable with a 15-pin male DB15 connector. The User I/O provides proprietary system control signals
- A 1/4-inch phone-jack style connector for an optional temperature probe.

2.3 System Features

The Digital Sonifier includes the following features:

- Front-panel system On/Off switch
- Separate front-panel Stop and Pause buttons for experiment cycles
- Power output of up to 200 watts (Model 250) and up to 400 watts (Model 450)
- Nominal 117 Volt (North American) and 200-245 Volt (export) models available (factory set)
- Multiple languages for display messages: English, Spanish, Italian, German or French.
- Front-panel LCD display, showing parameter settings, alarms and messages
- Membrane front panel with numeric keypad for parameter entry and function selection
- Digital parameter setting, with valid parameter range checking
- Twenty (20) presets for different parameter Setups
- Digital Wattmeter
- Front panel Bargraph display of relative power while running
- Amplitude control, analog, adjustable while running
- Pulse or Continuous operation
- Temperature option
- Sample Hold using Pulse/Pause operation
- Digital Timer (9 hours, 59 minutes, 59 seconds)
- Automatic end-of-cycle using Limits
- Factory-tuned 20 kHz ultrasonic design, requires no user adjustment
- Parallel Printer interface
- Printed Report capability, with date stamp and parameter information
- Serial interface (for remote computer or terminal)
- User I/O, offers remote start/stop control

For additional feature information, please contact your Branson representative.

For Your Notes

3 Delivery and Handling

3.1 Delivery and Handling

The Digital Sonifier has no special handling constraints. On receipt of your Digital Sonifier system, take the following steps:

1. Inspect the carton for signs of damage.
2. Open the carton and locate the packing list.
3. Carefully unpack the components and check them against the packing list.
4. Save all packing materials in case the equipment needs to be shipped.
5. Inspect the components for any damage that may have occurred during shipping.

Report all shipping damage to your carrier.

For Your Notes

4 Installation and Setup

4.1	Installation Checklist	4-1
4.2	System Block Diagram	4-2
4.3	System Component Description	4-2
4.4	Assembling the Equipment	4-9
4.5	Input Power Requirements	4-13
4.6	Electrical Connections to Equipment	4-13
4.7	Guards and Safety Equipment	4-17
4.8	Ultrasonic Test	4-18

4.1 Installation Checklist

To install the Digital Sonifier, you will need these items:

- Digital Sonifier unit
- Power cordset
- Converter
- Horn (and horn tips, if applicable)
- Spanner wrench (can be ordered from Branson; refer to Appendix C.)
- Open-ended wrench (can be ordered from Branson; refer to Appendix C.)
- Any accessories shipped with the unit
- Any customer-supplied items, (i.e., computer, printer, and temperature probe)

Refer to *Appendix B, Optional Items Parts List*, for specific parts required for the optional items, and to *Appendix C, Accessories Parts List*, for parts needed for the available accessories.

4.2 System Block Diagram

The block diagram shows the relative interaction of the components of a Digital Sonifier system. The items inside the bold outline are found in the Digital Sonifier unit. Some elements shown are optional.

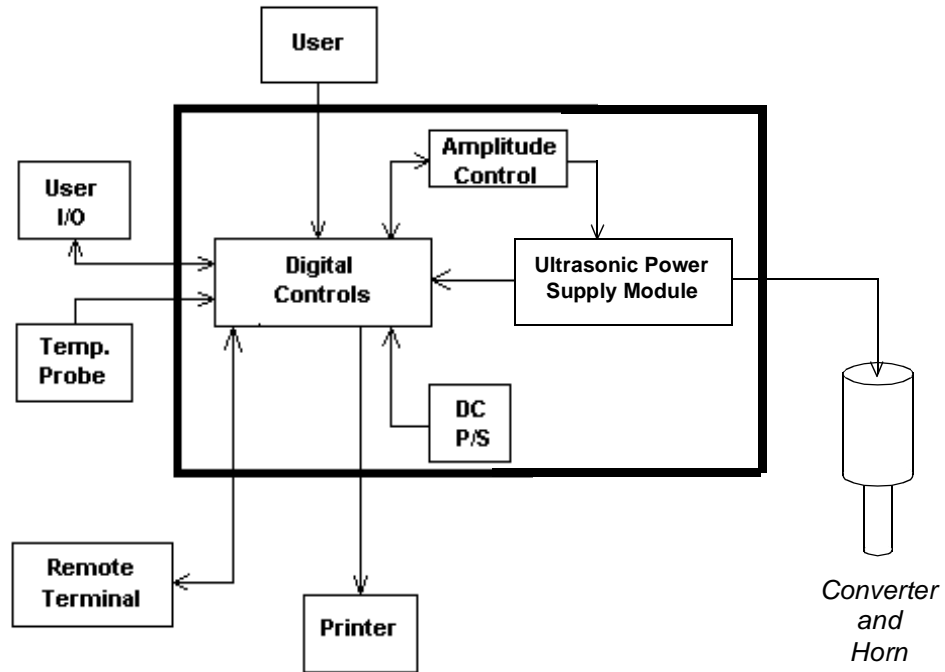

4.3 System Component Description

4.3.1 Standard Components

The standard system components are:

- Sonifier unit
- Power cord
- Converter
- Horn (and tips)

4.3.2 Optional Items

A complete list of optional items is provided in Appendix C of this Guide.

- Printer: Epson FX-compatible dot-matrix printer with a parallel-port interface with a DB25M cable connector only.
- Remote Terminal or Computer: Any user-provided computer or terminal that allows ASCII data to be transferred over an RS-232 serial interface. The pin-out of the serial connector is listed in '*Remote Terminal Connection*' on page 4-14. The computer interface, software and setup are for the reader to determine.
- Temperature Probe: Omega Technologies model #OL-703-PP, 0.125 inches in diameter and 4.5 inches in length. This item is sold separately by Branson.

Refer to the *Appendix B, Optional Items Parts List*, for information about specific parts needed for the optional items.

4.3.3 Accessories

Disruptor horns, various horn tips, and a variety of chambers or vessels for batch or continuous processing are available for use with Branson Digital Sonifiers. For a list of Accessories, refer to *Appendix C, Accessories Parts List*.

Microtips

Particularly useful for processing small volumes, microtips are available in several designs, tapered and stepped, to meet your application requirements. A Coupling Section may be used with a microtip horn for certain applications.

Microtips, Coupling Section and Disruptor Horn

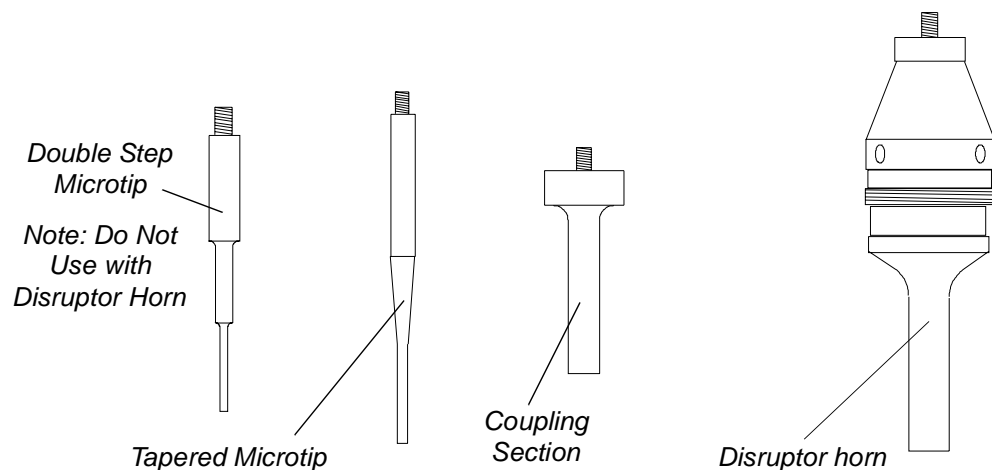

j**CAUTION**

DO NOT allow the horn or microtip to contact lab stands, beakers, test tubes or similar objects. Microtip failure may result. Breakage of glassware may result in the loss of a specimen.

Disruptor horns are the base for many microtip applications. Disruptor horns are threaded so that they may also be inserted into a Flow-Thru chamber attachment (see page 4-6). When threaded together, a closed chamber is formed between the Tissue Disruptor and the cavity of the Flow-Thru Attachment. The Tissue Disruptor may also be used alone.

The Tapered Microtip attaches directly to a standard 1/2 inch tapped Disruptor horn. The amplitude at the end of a tapered tip is three and one-half times greater than that of the standard horn. The tapered tip is recommended for difficult applications such as spores, fungi, yeast, muscle, and connective tissue. Excellent results can be achieved on volumes ranging from 3 to 20 ml in a comparatively short period of time. The diameters of the tapered micro tips are 1/8 inch (3.2 mm), 3/16 inch (4.8 mm), and 1/4 inch (6.4 mm).

The stepped microtip is a two-piece unit, consisting of a Coupling Section and a lower double-step tip. Because the coupling section is attached directly to the converter, the standard disruptor horn must be removed prior to using the stepped microtip. Recommended for use on extremely small volumes, the stepped microtip can be used to treat volumes ranging from 0.5 to 20 ml. Applications for this tip include red and white blood cells, tissue culture cells, HeLa cells, and the complete range of cells that have low to medium resistance to breakage.

To prevent foaming or aerosoling while processing small quantities with the tapered or stepped microtips, the use of a conical-shaped tube such as a reaction vial or a cut down centrifuge tube is recommended.

j**CAUTION**

When using microtips, do not exceed a maximum Amplitude Control setting of 70%. The microtip will break if driven at higher amplitudes.

Tissue Disruptor

Designed for disintegration of difficult tissues, this stainless steel accessory has a specially constructed cell bottom that holds up to six grams of tissue. A water jacket may be provided for cooling.

Cup Horn

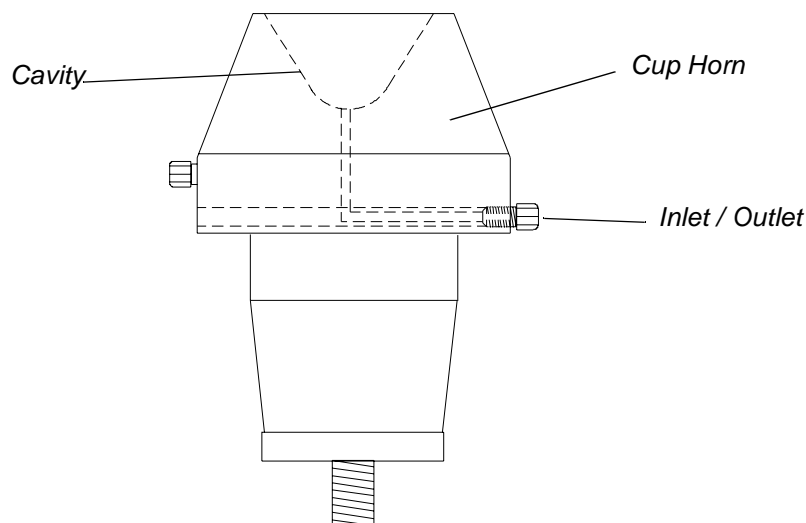

Cup Horns allow materials to be treated in small vials or test tubes without immersing the ultrasonic horn or micro tip in the material, thereby providing completely sterile conditions. A Cup Horn is attached directly to the converter, and the assembly is mounted upside-down on the lab stand with the Cup Horn at the top. With chilled water in the Cup Horn, test tubes are suspended in the Cup with the contents of the tubes just below the water level. Ultrasonic energy is then conducted from the surface of the horn, through the water and test tube walls, to the contents of the tube.

Some energy loss may occur when applying ultrasonics in this indirect way, and processing can take longer than if the ultrasonic horn were immersed directly in the solution.

There are two types of Cup Horn, a high intensity unit that will accommodate a single test tube, and a larger unit for multiple test tubes. The high intensity Cup Horn has a concave bottom that focuses the ultrasonic energy on the bottom of the tube. The larger unit, with a diameter of two or three inches, allows the immersion of multiple test tubes. The larger Cup Horns have clear plastic walls, which permit easy viewing of the activity in the tubes during processing. Both types of Cup Horn are designed to allow chilled water to circulate through the cup to prevent heating of the solution as a result of the ultrasonic activity.

CAUTION

j

The bottom of the test tubes should not be in contact with the surface of the ultrasonic horn. Such contact could cause breakage and loss of sample.

Flow-Thru Horn

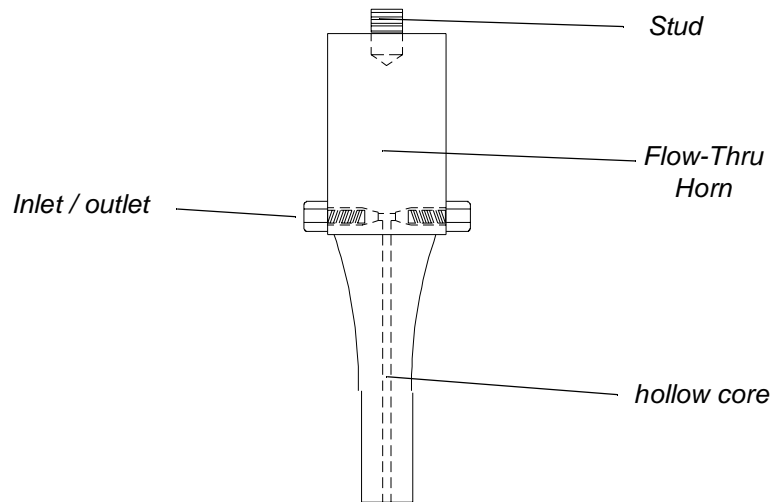

The Flow-Thru Horn has two inputs or orifices at the non-vibrating, nodal point of the horn. A pre-mixed substance is fed through one of the inputs while the horn is ultrasonically activated. Because two inputs are available, two different types of material can be treated simultaneously for mixing or emulsifying. The processed solution exits at the tip of the horn. The horn can be used as a continuous-flow device to collect the solution in one large vessel.

Continuous-Flow Attachment

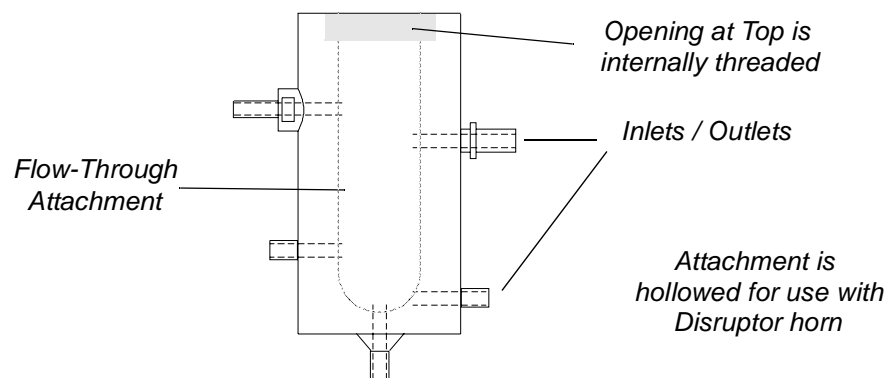

This attachment, which is screwed onto the disruptor horn, permits continuous processing of low-viscosity materials at rates of up to 38 liters per hour. Designed primarily for emulsifying, dispersing, and homogenizing, the attachment will disrupt most cells, with the exception of the more difficult species. The materials being treated can be passed through the attachment more than once to obtain desired results. For cooling, a water jacket with input, output, and overflow connections is provided.

Rosett Cell

The Rosett Cell, made of borosilicate glass, has a conical shape with three side arms, through which the solution is driven by pressure produced from vibrations from the ultrasonic horn, thereby exposing the substance to ultrasonic energy repeatedly during circulation. When the Rosett Cell is immersed in a cooling bath, the enlarged glass surface area and circulation through the side arms provide an efficient means of heat exchange.

The Rosett Cell is available in three sizes: 8-25 ml, 25-180 ml, and 35-300 ml.

Flow-Thru Rosett Cell

The Flow-Thru Rosett Cell is equipped with its own water cooling jacket, with intake and output connections for continuous processing and a double chamber for cooling. Normally, adequate cooling can be achieved by connection to the cold water tap or by using a closed circuit system. An ice/salt water solution will maintain a temperature below 0°C. Since the double chamber is made of glass, the substance can be easily observed during treatment. The Flow-Thru Rosett Cell is not suited for difficult cells.

Soundproof Enclosure

Although ultrasound is above the normal range of human hearing, audible sound sometimes occurs when liquids are treated ultrasonically, especially due to cavitation produced by ultrasonic vibration. The Soundproof Enclosure can be used to reduce this to an acceptable level. It is especially useful when the Sonifier is used for extended periods of time.

The Soundproof Enclosure is also useful at minimizing splashing while the experiment is running. Cooling within the enclosure may be required for certain applications. Detail of the enclosure may vary from those depicted below.

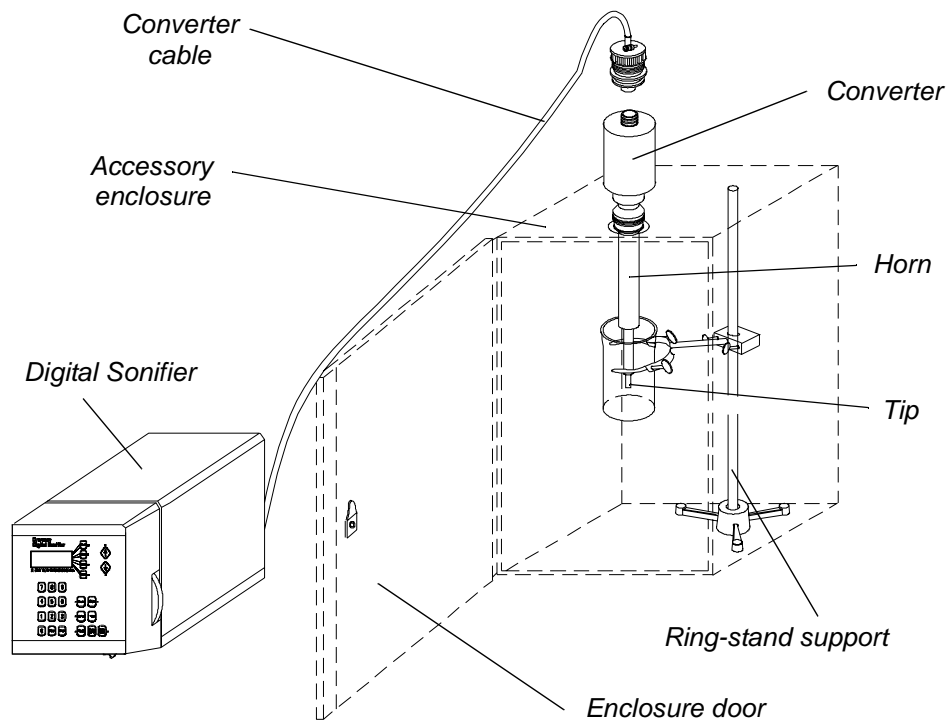

4.4 Assembling the Equipment

The Digital Sonifier unit is pre-assembled and requires no special tools, however other components must be connected to the unit in order for the system to operate. Some assembly of the ultrasonic horn is required, as described in the following sections.

4.4.1 Setup Procedure

To set up your Digital Sonifier for an experiment, take the following steps:

Step	Action
1	Connect the tip, horn, and converter, following the procedure in <i>Section 4.4.2, Connecting Tips, Horns, and Converters</i> , on page 4-10.
2	Mount the converter/horn assembly in a laboratory stand or other suitable support. Secure the clamp on the converter housing.
3	Set the ON/OFF switch on the front of the unit to the O (OFF) position
4	Plug the line cord into the unit, and then into an appropriate electrical power outlet, ensuring that the power supply is grounded to prevent electrical shock.

To remove a horn, use spanner wrenches shipped with the system. Never attempt to remove a horn by holding the converter housing in a vise. If necessary, secure the largest portion of the horn in a soft-jawed vise. See *Section 4.4.2, Connecting Tips, Horns, and Converters*, on page 4-10.

4.4.2 Connecting Tips, Horns, and Converters

Connecting the Horn to the Converter

To connect the horn to the converter, take the following steps:

Step	Action
1	Clean the contacting surfaces of the converter and horn, and remove any foreign matter from the threaded stud and threaded hole.
2	Coat one of the mating surfaces completely with a very thin film of silicone grease (without additives), using an amount about the size of a paper match head. Excessive silicone grease can diminish performance.
3	Thread the horn stud into the converter and tighten, using spanner wrenches. The recommended torque is 220 inch-pounds (24.85 Nm).

A standard flat tip, recommended for processing liquids, is supplied with tapped horns. Other tip configurations are available for experimental work on applications where the ultrasonic vibrations are transmitted directly into the solution. The shape of the horn influences the direction in which the ultrasonic vibrations are delivered from the horn.

Connecting the Tip to the Horn

To attach the tip to the horn, take the following steps:

Step	Action
1	<p>Clean contacting surfaces of the horn and tip, and remove any foreign matter from the threaded stud and threaded hole.</p> <hr/> <p>CAUTION</p> <p>j The tip must be installed clean and dry, or the power supply may not tune and operate correctly.</p> <hr/>
2	Hand-assemble the tip to the horn.
3	<p>Using a spanner wrench on the horn and an open-end wrench on the tip, tighten the tip. See Figure 4.3. Torque specifications for the various threaded tips follow:</p> <p>1/4-20 — tighten at 90 inch-lbs./10.16 Newton-meters</p> <p>3/8-24 — tighten at 180 inch-lbs./20.33 Newton-meters</p>

Tightening a tip on a horn, using spanner wrench and open-end wrench

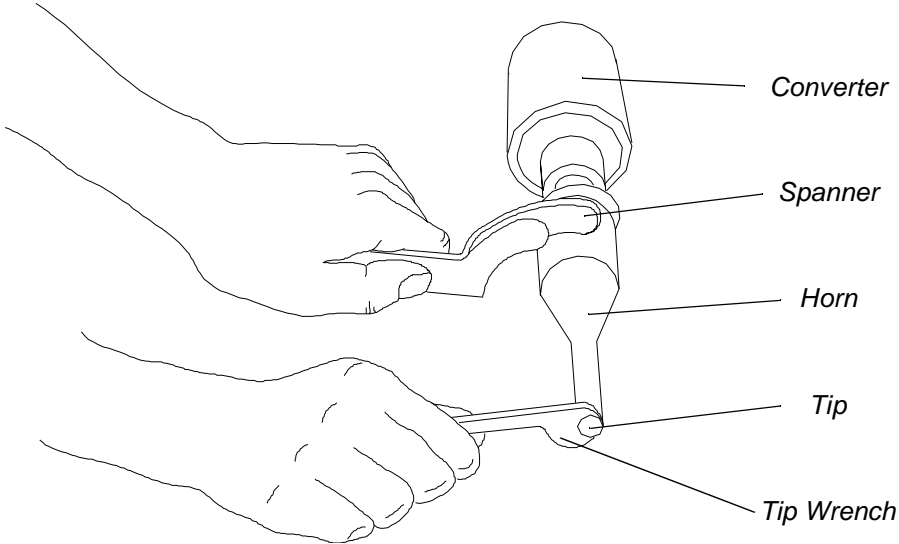

4.4.3 Horn Amplitudes

Use the following charts to determine the correct system settings for the horns you are using.

Suggested Amplitude Values for various Horns

Horn EDP No.	Description	Amplitude Control Settings		
		10%	50%	100%
101-147-037	1/2" Diameter Tapped Stepped Disruptor	21.0* 0.0008"	76.0* 0.0029"	145.0* 0.0057"
101-147-042	1/2" Diameter Solid Catenoidal Disruptor	21.0* 0.0008"	76.0* 0.0029"	145.0* 0.0057"
101-147-041	1/2" Diameter Solid Exponential Disruptor	10.0* 0.0004"	34.0* 0.0013	65.0* 0.0026"
101-147-039	3/8" Diameter Solid Stepped Disruptor	36.0* 0.0014"	125.0* 0.0049"	240.0* 0.0094"
101-147-043	3/4" Diameter Solid Stepped Disruptor	9.5* 0.0004"	33.0* 0.0013"	63.0* 0.0025"
101-147-035	3/4" Diameter Solid High Gain Disruptor	19.0* 0.0007"	68.5* 0.0027"	130.0* 0.0051"
101-147-044	1.0" Diameter Solid Stepped Disruptor	6.3* 0.0002"	21.5* 0.0008"	40.5* 0.0016"

* All measurements in microns unless otherwise specified

Approximate Microtip Amplitudes

Horn EDP No.	Description	Amplitude Control Settings		
		10%	40%	70%
101-148-062	1/8" Diameter Tapered	116.0* 0.0046"	306.0* 0.0122"	494.0* 0.0194"
101-148-069	3/16" Diameter Tapered	59.5* 0.0023	183.0* 0.0072"	302.0* 0.0119"
101-148-070	1/4" Diameter Tapered	59.5* 0.0023"	151.0* 0.0059	247.0* 0.0097"
101-063-212	Double Step	64.0* 0.0025"	173.8* 0.0068"	274.0* 0.0108"

* All measurements in microns unless otherwise specified

4.5 Input Power Requirements

The input power requirements for the Digital Sonifier are:

- 117 VAC, 50/60 Hz (North American model)
- 200-245 VAC, 50/60 Hz (Export models only)

The Digital Sonifier is equipped with an IEC-type power cord connector. The unit requires a single-phase, three-wire, 50/60 Hz power source.

j

WARNING

To prevent the possibility of electrical shock, always plug the Digital Sonifier unit into a grounded power source.

The system is fuse-protected with a replaceable glass fuse, 5x20mm, slow-blow type (refer to the data tag on the system. This fuse should never blow under normal operating conditions. The fuse holder is found on the rear of the unit, as part of the IEC power connector.

4.6 Electrical Connections to Equipment

All of the connections to the Digital Sonifier are made to the rear of the unit using industry-standard connectors. Refer to *Section 2.2.3, Back Panel Connections*, on page 2-8 for connector locations. See Appendix B and C for accessory part numbers.

4.6.1 Power Cord

North American units are shipped with a 3-conductor 117 Volt cordset (NEMA 5-15P to IEC jack). It connects to an IEC-type connector on the rear of the unit. The plug end connects to your main voltage receptacle, which should be properly fused (depending on your site requirements). It requires a conventional NEMA 5-15R receptacle for installation.

Export units are shipped with a standard Harmonized European cordset (having an IEC-type jack).

j

CAUTION

If your cordset does not match your main power receptacle, verify that you have the correct voltage available. Do not connect the system if the voltage rating of the unit is incorrect for your location, as this can damage the unit.

4.6.2 Remote Terminal Connection

The remote terminal is connected to the rear of the Digital Sonifier through an industry-typical RS-232 connection. See *Back Panel of Digital Sonifier* on page 2-8 for the RS-232 connector location. The RS-232 connector pin-out is provided below; the connection only supports three data leads (Ground, RxD and TxD) and does not support handshaking (see *Remote Computer or Terminal* on page 6-34 for other Setup information). The serial connection requires a straight-through cable with a 9-pin DB9 male connector with the following leads supported; the remote end of the cable should match your Remote Terminal device.

RS-232 Connector Pin-out

RS-232 Connector Pin (DB-9F on system)	Pin Designation	Common Signal Name
2	RxD	Received Data (at unit)
3	TxD	Transmitted Data (from unit)
5	Gnd	Signal Ground

The other leads of the RS-232 connector (DB9F) are not supported.

The remote terminal connection should not exceed a 50 foot (15 meters) cable length using conventional data cabling.

4.6.3 Terminal Connection

A Terminal is a display option that is available through Branson. The terminal is used as a remote terminal device and connects to the unit as such. In order for the terminal to operate with the RS-232c serial port of the Digital Sonifier, its configuration options must be set to match those of the Digital Sonifier's output.

4.6.4 Printer Connection

The printer is connected to the back panel of the Digital Sonifier (female DB-25 connector) to a conventional 25-pin parallel printer cable. Your printer cable must have the male DB-25 connector. Plug the printer cable into the connector and turn the printer on. The Printer must be Set Up in order to function (see page 6-18).

4.6.5 Temperature Probe Connection

The temperature probe is connected to the Digital Sonifier using a 1/4 inch RCA-type phone jack connector. The Omega Temperature Probe that is specified matches properly, and is the only temperature device for use with the Digital Sonifier. The Probe temperature is displayed (example on page 6-32), or the display will shown TEMP OFF if no probe is connected.

4.6.6 User I/O Connection

The Digital Sonifier is equipped with a standard external connection to allow you to design and connect your own custom interface for controlling the unit. The User I/O interface can be useful when you need to activate the Sonifier remotely, for example, when the operator must start and stop the unit from another room for safety reasons.

User I/O Pin-Out (DB15F) provided for customer-designed interface

DB15F Pin	Function	Signal or Use
1	+5 VDC Source	+5 VDC source (ref. pin 6) when front-panel Power Switch is On
2	Signal Ground (for Amplitude)	Signal Ground
3	Signal Ground (for Power)	Signal Ground
4	Signal Ground (for Temperature)	Signal Ground
5	Amplitude Signal Output	0-10VDC = 0-100% Amplitude
6	+5 VDC Return	+5 VDC Ground
7	not used	no connection
8	not used	no connection
9	Start/Stop Control	Apply +5VDC (from pin 1) to Start, open circuit to Stop
10	Temperature Limit	+5VDC signal drops to 0VDC when the Temperature Limit is reached
11	Test or Running	+5VDC signal drops to 0VDC when Running
12	Power Signal Output	0-10VDC = 0-100% Power Out
13	Temperature Signal Output	0-10VDC = 0-100 degrees C or 32-212 degrees F
14	Signal Ground Reference	Signal Ground
15	not used	no connection

Each user-control application may be different, it is left to the reader to design and create the customer-end portion of a User I/O interface. Use the signal information provided on the previous page. An example of one possible application is shown in the following diagram.

Example of Customer-Provided Application using the User I/O

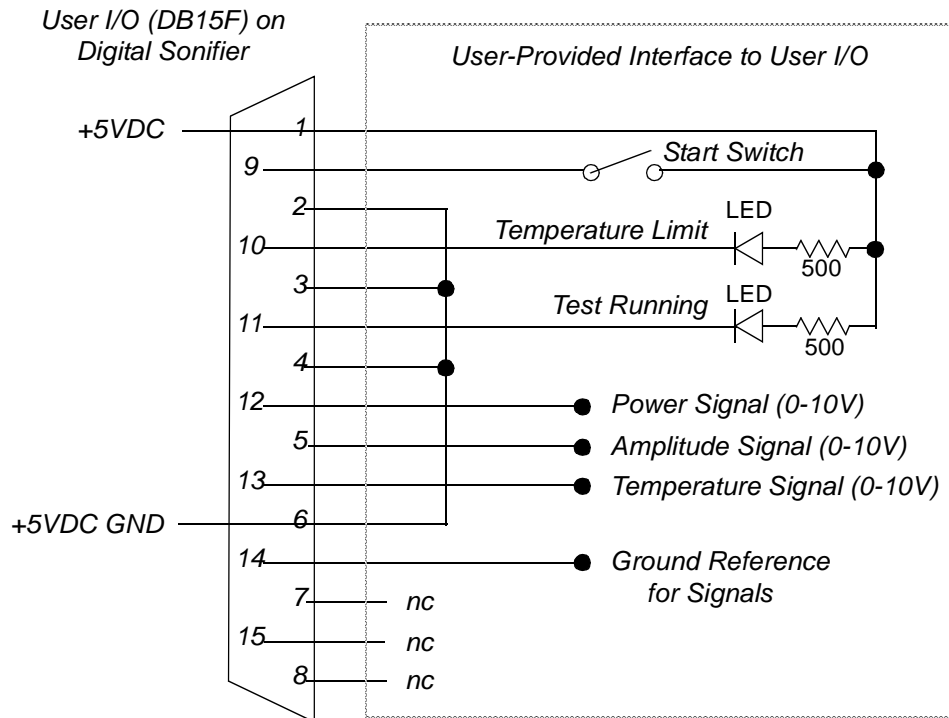

- Start switch can be tied to pins 1 and 9 as shown. this will provide 5 volts in case the customer does not have a supply to operate user I/O signals.
- Pins 2 and 6 must be tied together for proper Start signal operation.
 Note: These must NOT be tied to earth ground. Noise due to ground loops could be injected onto the signals. This will cause improper operation, but will not damage the unit.
- Pins 3 and 4 must be tied to pin 6 for operation of the Temperature Limit and Test Running LED's respectively, as shown.
- Power, Amplitude and Temperature must be referenced to pin 14 for proper signal measurement.

4.7 Guards and Safety Equipment

Although the Digital Sonifier operates outside the normal range of human hearing, some applications can create audible noise above 85dB. If an uncomfortable level of noise is present, the operator should wear ear protection for safe operation.

Appropriate eye protection should be worn when operating the Digital Sonifier, to prevent possible splash injury originating in the solution.

j

WARNING

The Ultrasonic Horn can cause injury and/or equipment damage during operation. To avoid injury or accident, never touch the Ultrasonic Horn while the System is turned on, and do not allow the Horn to come in contact with solid vessels or supports.

The User I/O may be used to remotely control the System. If this is the case, you must design in whatever safety precautions are appropriate to your User I/O circuit design to prevent unexpected start-up, which can cause personal injury and can cause equipment damage.

4.8 Ultrasonic Test

The Test button on the front panel of the Digital Sonifier is used to verify that the unit is functioning (providing ultrasonic energy to the Converter and Horn). Later, you can run another test on the system for your particular experiment (described in *System Performance Benchmark* on page 5-3).

Before testing the Sonifier, always make sure that the horn is not touching anything. The System also performs several self-tests when it is first turned on.

Step	Do this...	To obtain this result
1	Set up the Digital Sonifier following the instructions in this manual. If no horn is currently installed, <ul style="list-style-type: none"> • Mount a 1/2" Disruptor horn (with a flat tip, if tapped) to the Converter. 	Prepare the Sonifier to operate, if it was not previously assembled.
2	After you have connected the Converter/Horn to the Converter Cable, verified all other connections are as desired: <ul style="list-style-type: none"> • Turn the Unit On, and observe the self-test displays. 	Verify that the system passes all its self-tests, observing that there are no error messages on the front panel display. The Digital Sonifier advances to the "Ready" mode and shows the normal Ready display (see page 2-4).
3	Adjust the Amplitude control to approximately 50% (observe the value on the front panel display).	Ensures that ultrasonic energy will be at some mid-range value, and will not cause damage if you were using a microtip (must be less than 70%).
4	Verify that the Horn is not touching anything. <ul style="list-style-type: none"> • Press the Test button on the front panel. Observe the front panel display. 	Verifies the ultrasonic output of the system. You may hear a soft, high-pitched sound. The bargraph display will show some output value. The test will run for 2 seconds, then stop.
5	If the system showed readings on the display during the Test, you may either proceed with your experiments, or <ul style="list-style-type: none"> • Turn the unit off. 	Verification that the Digital Sonifier is operating and is ready to be set up for your experiment.

5 Technical Specifications

5.1 Technical Specifications - - - - - 5-1
 5.2 Physical Description - - - - - 5-2
 5.3 System Performance Benchmark- - - - - 5-3

5.1 Technical Specifications

The following table outlines the technical specifications for the Digital Sonifier:

Controls and Displays	Digital keypad entry for parameters; 4-line x 20 character LCD display; rotary Amplitude output control; remote terminal control; printer output; main power switch, temperature probe input
Amplitude control	Adjusts amplitude of power supply output voltage. Range: 10% – 100% of nominal converter amplitude
Duty Cycle	Intermittent – pulse duration adjustable [0.1 seconds – 59.9 seconds] or continuous processing time
Horn Frequency	19.850 – 20.050 kHz
Line Voltage	115V ± 10% @ 50/60 Hz (North American unit) 200-245 ± 10% @ 50/60 Hz (Export only)
Power	250 – up to 200 watts* 450 – up to 400 watts*
Temperature (ambient)	Operating: 41°F (5°C) to 104°F (40°C). Storage and shipping: -20°F (-29°C) to 158°F (70°C)
Tuning	Factory set, no tuning necessary. No user-accessible adjustments.

* Amplitude control at maximum setting. (System settings are covered in Chapter 6.)

5.2 Physical Description

The following table outlines the physical characteristics of the Digital Sonifier.

Converter Weight	4 lbs. (1.8 kg) with horn
Converter Length	7 inches (180 mm)
Converter Diameter	2-1/2 inches (60 mm)
Horn Tip Diameter	1/8 inch – 1.0 inch (3.2 – 25.4 mm), depending on process needs and Accessory Tip selected
Power Supply Weight	17 lbs. (7.7 kg)
Temperature Probe	Omega Technologies model #OL-703-PP. It is 0.125 inches in diameter and 4.5 inches long

5.3 System Performance Benchmark

Each application and system configuration is slightly different. System performance will vary when you change setup parameters and if your horn or tips change, and can affect the results of your experiments. Creating a benchmark of your initial setup and performance can be useful at a later date in identifying a change in performance, and can also help in recreating your exact initial setup.

The following steps are used only to record system performance, not your experiment results.

i **NOTE**
Make copies of the following page and keep it on file for future reference.

Use the following steps to create and record a benchmark for your exact setup.

Step	Action to Save a Benchmark
1	Make a copy of the Digital Sonifier Setup Form provided on page 5-4.
2	Identify your experiment type on the form, your own reference. Set up the Digital Sonifier (be ready to run), and prepare your experiment. Turn the Digital Sonifier system On.
2	Set your desired Amplitude control setting (the value is displayed on the bottom line of the LCD display) and write the value in the value on the form.
3	With the Horn submersed in your solution, press the Start button (located on the bottom right-hand side of the Sonifier's keypad). Note any special immersion comments (depth, how it is supported, etc.)
4	Note the Bargraph reading (the value is displayed on the bottom line of the LCD display) on the form.
5	Press the Down Arrow key on the keypad and view the POWER reading (the value is displayed on the bottom line of the LCD display). Record the POWER reading on the form.
6	Note any special adjustments, settings, operating modes, or other system variables that will be helpful at a later time in re-creating your setup. If you use a Preset, note the Preset ID.
7	Turn the system off. Record the serial numbers and horn information of the Digital Sonifier unit, Horn, Converter, and any special equipment. Special information about the Horns is etched into the horn.
8	Place the filled-in form in a safe place for future reference.

If you are using the Printer option, you may wish to print a report of the results and keep it on file with the form.

Branson Digital Sonifier Setup Form

Make a copy of this form and use it to record a benchmark for your system's setup.

Date: _____ Operator: _____
Experiment/Solution: _____
Digital Sonifier Model: 250 450 117 Volt 200-245 Volt
Unit Serial Number: _____

Converter Serial Number: _____

Horn Type: _____

Parameters, Mode, Preset: _____

Amplitude setting (LCD read-out): _____

Bargraph reading: _____

Power Reading: _____ watts

Other Setup Notes:

6 Operation

6.1	Setup and Operation	- - - - -	6-2
6.2	Front Panel Controls	- - - - -	6-5
6.3	Entering System Setup Parameters	- - - - -	6-9
	System Setup - Language	- - - - -	-6-10
	System Setup - Date	- - - - -	-6-12
	System Setup - Time of Day	- - - - -	-6-14
	System Setup - Temperature Units	- - - - -	-6-16
	System Setup - Printer	- - - - -	-6-18
	System Setup - Printer Model	- - - - -	-6-20
	System Setup - Reports	- - - - -	-6-22
6.4	Entering Operation Parameters	- - - - -	-6-24
	Parameter Entry - Time	- - - - -	-6-26
	Parameter Entry - Maximum Temperature	- - - - -	-6-28
	Parameter Entry - Pulse On and Pulse Off	- - - - -	-6-30
	Parameter Entry - Pulse Temperature	- - - - -	-6-32
6.5	Remote Computer / Terminal	- - - - -	-6-34
	Enter a parameter using the Remote Terminal	- - - - -	-6-34
	System Setup - Remote Terminal	- - - - -	-6-36
	System Setup - Baud Rate	- - - - -	-6-38
6.6	Save and Recall Presets	- - - - -	-6-40
6.7	Printing/Sending Reports	- - - - -	-6-41
6.8	Displays During the Experiment	- - - - -	-6-42
	Runtime Displays	- - - - -	-6-42
	Remote Terminal Displays	- - - - -	-6-43
6.9	Warning and Error Messages	- - - - -	-6-44

6.1 Setup and Operation

j

WARNING

Do NOT touch the vibrating horn, or place the vibrating horn against solid objects such as beakers and crucibles. Touching or holding the horn can result in burns or injury, and contacting solid materials with the vibrating horn or tip can cause breakage.

j

CAUTION

DO NOT run the microtip above an Amplitude setting of 70%. Doing so can cause damage to the microtip assembly.

System Modes

You can control the way in which ultrasonics are applied to your sample by setting the unit to operate in one of several different modes. You determine the mode in which to operate by specifying parameters for your experiment. There are five system modes, as described below:

- **Continuous Mode:** Ultrasonics are applied to the sample until you Stop or Pause the experiment.
- **Timed Mode:** Ultrasonics are applied to the sample for a period of time that you specify by setting the Time parameter.
- **Pulse Mode:** Ultrasonics are turned on and off repeatedly during the experiment. You specify the length of the intervals in which ultrasonics are on and off. For example, you can specify 0.5 seconds for the Pulse On parameter and 2.1 seconds for the Pulse Off parameter. You can also specify a time limit using the Time parameter, and/or a temperature limit using the Temperature parameter.
- **Temperature Mode:** Ultrasonics are applied until the sample reaches a temperature that you specify by setting the Temperature parameter. The Temperature Mode requires the optional Temperature Probe, and operates as follows:
 - when no TIME or PULSE TEMP parameter is entered, the experiment stops when the MAX TEMP value has been reached.
 - When a TIME and MAX TEMP value have been entered, the experiment runs until the TIME has elapsed. If the MAX TEMP is reached before the TIME parameter has elapsed, ultrasonic vibrations will temporarily stop (and the timer will stop counting) until the Probe Temperature has dropped by 3 degrees below the MAX TEMP setting, at which point the timer and the ultrasonic vibrations resume. The front panel display shows the proper ultrasonics active displays.
- **Pulse/Pause Mode:** Used for holding an experiment within a desired temperature range. Ultrasonics are applied to the sample while keeping the sample's temperature between the Pulse Temperature value and the Maximum Temperature values that you specify. This allows you to limit temperature buildup in the sample while continuing ultrasonic treatment until you obtain the process results that you want.

Pulse/Pause Process Cycle

In Pulse/Pause Mode, the system applies ultrasonics (either Pulsed or not) to the sample until it reaches the Pulse Temperature. The system then adjusts (or sets) the Pulse On/Pulse Off times for this continuing process, in order to slow the heating process of the sample. When the experiment reaches the Maximum Temperature, ultrasonics are turned off temporarily until the sample's temperature drops three degrees (either Celsius or Fahrenheit), at which point ultrasonic treatment resumes, using the Pulse On-time/Pulse Off-time ratio calculated by the system, until the Maximum Temperature is reached and ultrasonics are once again turned off. This process is repeated until you manually stop the experiment or until the Time that you specified as a limit has elapsed. While the experiment is running, the current and Maximum Temperatures are displayed and updated every second.

Limits

You may wish to set a Time or Temperature value as a Limit for some experiments. This will cause the experiment cycle to Stop if either the indicated Time has elapsed or the maximum Temperature was reached. If a Limit is not desired, the parameter should be set to OFF.

The following chart summarizes the System Mode options, including the use of Limits:

	Time setting	Pulse On and Pulse Off settings	Max. Temp setting	Pulse Temp. setting	Cycle Ends upon...
Continuous Mode	OFF	Both OFF	OFF	OFF	Stop button or remote command
Timed Mode	Your Time parameter	Both OFF	OFF or Limit	OFF	Time parameter elapses
Pulse Mode	OFF or Limit	Pulse On and Pulse Off times	OFF or Limit	OFF	Stop button or remote command
Temperature Mode	OFF or Limit	Both OFF	maximum Temperature parameter	OFF	Maximum Temperature reached
Pulse/Pause Mode	OFF or Limit	Optional. The system will recalculate while running the process	Max. Temp set to upper temperature for process	Pulse Temp set to lower temperature for process	Stop button or remote command

i **NOTE**
 You must have a Temperature Probe attached to the unit to use the Temperature Mode, the Pulse/Pause Mode, or to use Temperature as a Limit.

System States

Availability of the Digital Sonifier's functions depends on the system state. The 'normal' state of the system for most users is the Run or Ready mode. Some remote terminal commands are noted where appropriate (commands have the format of an '?' followed by upper-case letter or letters, i.e. !TS for the Test command). These commands are also summarized in the Remote Terminal section found on page 6-35. The possible system states include:

- **Power-Up:** The system enters the Power-Up state when the power switch is turned on. The fan starts to run, and the system then enters the Self-Diagnostics state.
- **Self-Diagnostics:** In this state, the system performs hardware and software checks on itself. The front panel display shows several diagnostic displays (indicating which step in the self-diagnostics it is in) and the front panel LEDs will illuminate as a visible test. After it successfully completes this system check, it enters the Ready state.
- **Ready:** In the Ready state, the system is waiting to begin an experiment, and it can accept parameter settings that you enter through the keypad or the remote computer or terminal. The front panel display

shows the Amplitude setting and some parameters, and the appropriate LEDs are illuminated. The system must be in the Ready state for you to start a new experiment or make changes to any parameters.

- **Run:** After setting parameters for your application, pressing the **Start/Stop** button or sending a !ON command will Start your setup. Ultrasonic power is delivered to the horn (whether continuous or pulsed), and the front panel display will show the runtime information, including the percentage of power used on its bottom line as a bargraph display, and the LED next to the Start/Stop button remains lit while the application is running. If you set Limits, your application will Stop automatically upon reaching those limits.
- **Test:** From the Ready state, the system enters the Test state when you press the Test key or issue a !TS command to enter the Test state, causing ultrasonics to be sent to the horn. After two seconds, the system returns to the Ready state.
- **Print:** If you have a printer connected, and after running a cycle or testing the setup you may print a report of your experiment. Printing is started by pressing the Print/Send key or sending a !P command. After printing, the system returns to the Ready state.
- **Report:** If you are using the Remote Terminal option, and after running a cycle or testing the setup, you may send a report of your experiment from the system to your terminal. After the report is sent, the system returns to the Ready state.
- **Hold/Pause:** When you press the Hold/Pause key or issue an !H command during an experiment or test, the system stops operating, stops all timer functions, and enters the Hold/Pause state. To resume operation, press the Hold/Pause key again, or issue another !H command.
- **Stop/Abort:** When you press the Start/Stop button or issue an !OFF command, the system enters the Stop/Abort state. The experiment or test is stopped.

6.2 Front Panel Controls

The membrane keypad on the front panel of the Digital Sonifier allows you to enter parameters for both *System Setup* and *Operation* of the unit during a test or experiment. You can also use a remote computer or terminal to enter operation parameters. If a remote computer or terminal is enabled, you can lock out the keypad on the front panel of the unit if you want to operate the unit only from the remote computer or terminal. When the keypad is disabled through the remote computer or terminal, all keys except the Start/Stop key and the Pause key are disabled.

There are two additional controls (Amplitude Control and Power Switch) which work with the front panel controls, but are not actually part of the front panel. The remote computer or terminal may be used to control the system as well.

6.2.1 Power Switch

The Power switch for the system is located on the front of the unit, underneath the front panel controls. It is a simple rocker switch, on/off operation. When turned on, the front panel LEDs will light (during the power-up sequence), and the unit's fan will run.

6.2.2 Temperature Probe

The optional Temperature Probe is required for the Temperature Mode, the Pulse/Pause Mode, or to use Temperature as a Limit for your experiment.

6.2.3 Remote Terminal

An optional 'Remote Terminal' device may be used to setup and to run the experiment. The remote device can fully control the Digital Sonifier using the built-in serial interface. Instructions for using the remote computer or terminal and the Remote Terminal commands that you can use to enter parameters from your remote computer or remote terminal are described in *Section 6.5, Remote Computer or Terminal*, beginning on page 6-35.

i**NOTE**

'Remote Terminal' commands apply to a Remote Computer or a Remote Terminal. The Setup commands only indicate 'Remote Terminal' for simplicity.

6.2.4 Amplitude Control

The Amplitude control is found on the right side of the system chassis, it is a large circular control protruding through the side of the Front Panel. It rotates up and down to regulate the Amplitude value from minimum to maximum. The Amplitude value is displayed on the Front Panel display.

The Amplitude is displayed numerically on the bottom line of the Ready display in 1% units (to a system maximum of 100%), and after an experiment has been run. Amplitude may be adjusted while an experiment is running. An example of the Amplitude numerical display is shown in Figure 6.1 on page 6-7.

When the system is running, the Amplitude of the ultrasonic energy is displayed on the bottom line of the first page of the runtime display as a bargraph, in 5% increments. An example of the bargraph display is shown in *Section 6.8, Displays During the Experiment*, on page 6-44.

Figure 6.1 Digital Sonifier front panel, showing a Ready mode display including Amplitude

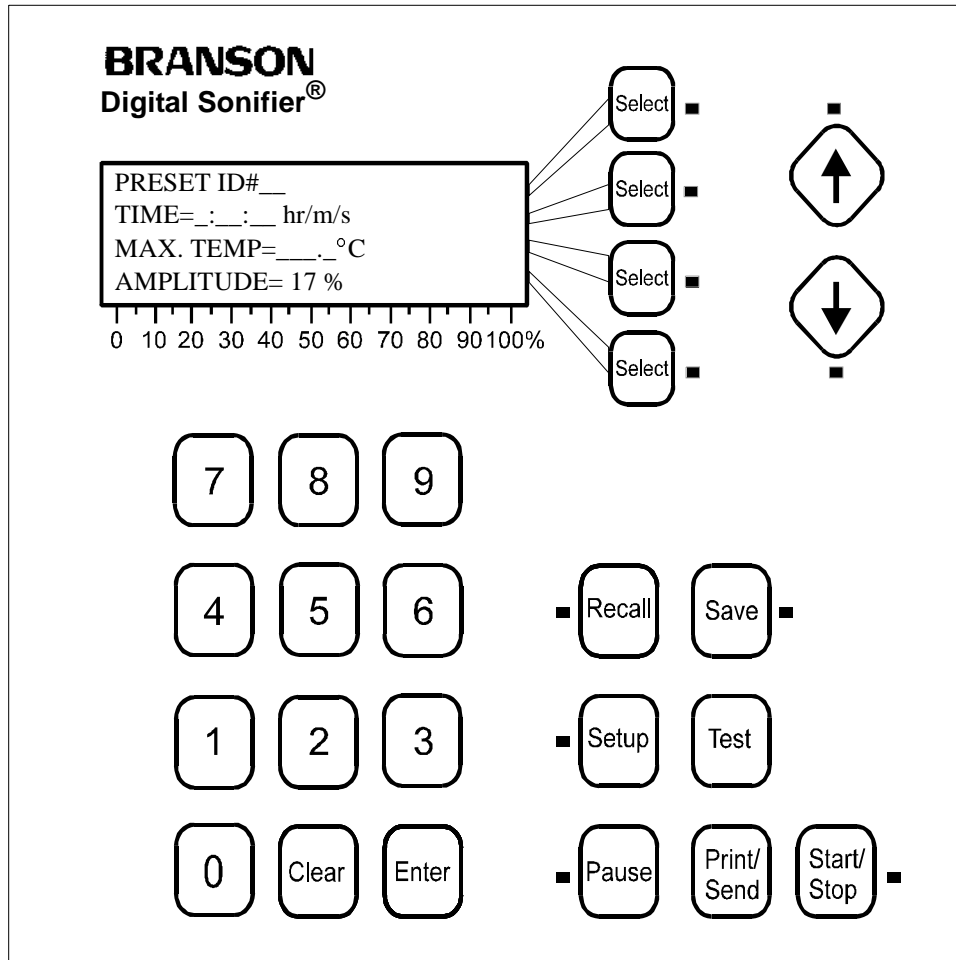

CAUTION

j

Do not use a sharp or pointed object to press the front panel controls. The soft-touch membrane front panel can be permanently damaged.

6.2.5 Menu Navigation

When the parameter selection menu is displayed, you can use the Page Up and Page Down arrows to navigate up and down between the pages of the menu to locate the parameters you want to change. If there are more menu options above the page currently displayed, the Page Up arrow LED is active. If there are menu options below the current page, the Page Down arrow LED is active.

Select buttons, when their parameters are available, will have their LED lit. The Feature buttons and Arrow keys will have their LEDs lit when those Features or options are active.

An error beep or tone will sound if a key that is unavailable is pressed, or if a parameter that is out-of-range has been keyed in. The system will not accept out-of-range parameters.

CAUTION

j

The **Start/Stop** button LED is illuminated while the experiment cycle is active, even if ultrasonics is not currently On (i.e. during an 'OFF' period in a Pulsed mode). Be careful to not touch the Horn when a cycle is active, as it may start without warning, and could cause injury.

Each menu line in the display shows a parameter whose value you can change, if its associated **Select** key LED is lit. The parameter can have either a numeric value that you enter with the numeric keys, or a choice that you select by toggling between a set of possible selections. You select a parameter for entry by pressing the Line Select key next to it. Then you key in the desired numeric value using the numeric keys, or the appropriate choice from a sub-menu using the Line Select keys.

When you press a Line Select key for a numeric parameter, the least significant digit of the parameter value flashes, and the numeric keys become active. You can:

- Key in a new value for the parameter, replacing the old value.
- Correct the value you are entering by pressing the **Clear** key to erase the value. You also use **Clear** to delete a parameter value to turn a parameter **OFF**.
- Press a different **Line Select** key to select a different parameter for entry, cancelling any changes you have made to the first parameter.
- Press an active **Page Up** or **Page Down arrow** key to view a different page of the Parameter Entry menu.
- Press the **Enter** key to store the new value, or to store a blank or an **OFF** value if you pressed **Clear**.

When you begin entering a value, the old value is replaced in the display by the new one. Once you have started entering a value, the other Line Select keys and the Page Up and Page Down keys become inactive. The Enter key must be pressed to leave the selected parameter.

When you press a Line Select key for a parameter that is a choice such as Yes/No or On/Off, the available values will be displayed in the menu. You select the desired value by pressing the Line Select key next to it and then pressing Enter to accept the value. The display then returns to the menu.

6.3 Entering System Setup Parameters

At System Setup, you can select and store system parameters such as time, date, language, remote operating parameters, and printer capabilities. The System Setup parameters can only be accessed from the membrane keypad, not from the remote terminal, and they are not available when a test or experiment is in progress.

To enter System Setup, press the Setup function key on the keypad to display the System Setup menu. On the menu, you will see the default values for each of the System Setup parameters. When you are finished with System Setup, exit the Setup menu by pressing the Setup key again. The Setup key becomes inactive, and the display returns to the Parameter Entry menu. The Enter key must be pressed before leaving the Setup menu to store any new parameter value.

If you change any system parameter, you must run at least a portion of a cycle in order to 'set' the values and enable the Printer and Report modes.

The parameters available at System Setup and their possible values are described in the table below. Detailed steps for each parameter are described in the pages that follow.

Table 6-1: System Setup Parameters

Parameter	Default	User Selectable Options
Printer	Off	Off, On
Remote (Terminal)	Off	Off, On
Language	English	English, Spanish, German, Italian, French
Temperature	°F	°F, °C
Time of Day	12:00	00:00 - 23:59 (24-hour format only)
Date*	01/01/1998	When the Language parameter is set to English, the date format is MM/DD/YYYY. For any other Language parameter, the date format is DD/MM/YYYY.
Reports	Disabled	Disabled, Enabled
Baud Rate (remote terminal)	9600	9600, 1200, 2400, 19200
Data bits (remote terminal)	8	N/A
Parity (remote Terminal)	None	N/A
Model (printer)	Panasonic	Epson

*The system's Date clock is "Year 2000" and Leap Year compatible, and may be set up through the year 2069.

System Setup - Language

The Language parameter affects the displays and the printed reports.

i **NOTE**
 The Language choice also affects the Date format, and the Reports sent to the Printer and/ or the Remote Terminal. See page 6-12 for additional information on Setting the Date.

Take this action...

To get this result...

Press the **Setup** key to display the **System Setup** menu. Its LED lights.

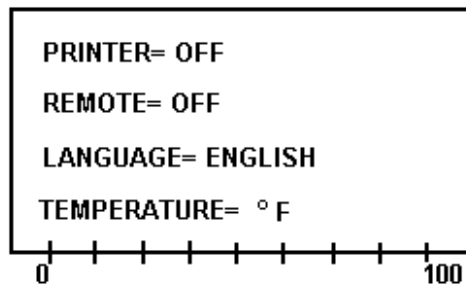

Use the **Up** and **Down** arrow keys, if necessary, to display the line showing the **Language** parameter.

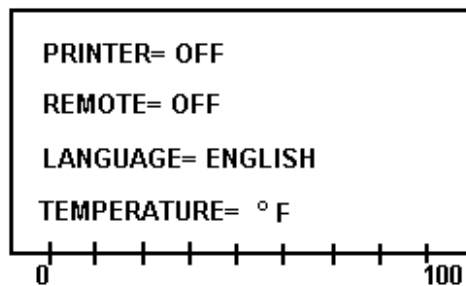

Press the **Line Select** key that corresponds to **Language**.

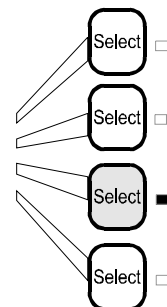
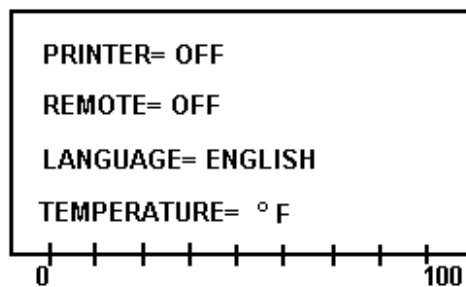

Press the same **Line Select** key again to toggle among the possible values for **Language: English, Spanish, German, Italian, or French.**

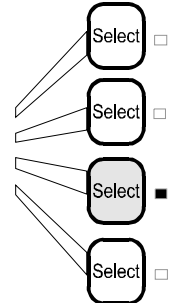
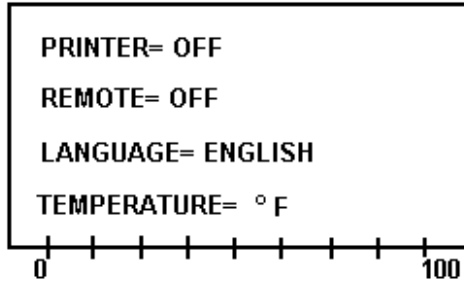

Press the **Enter** key to store the choice for **Language.**

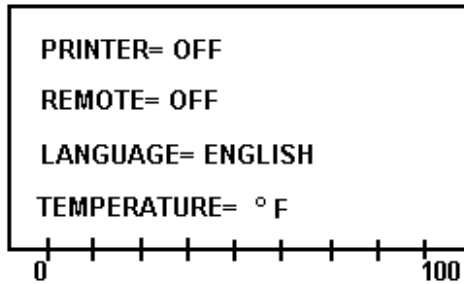

Press the **Setup** key to exit the **System Setup** menu. The **Setup** LED extinguishes.



System Setup - Date

The Date parameter affects the date shown on the display and printed on the Reports.

Take this action...

To get this result...

Press the **Setup** key to display the **System Setup** menu. Its LED lights.

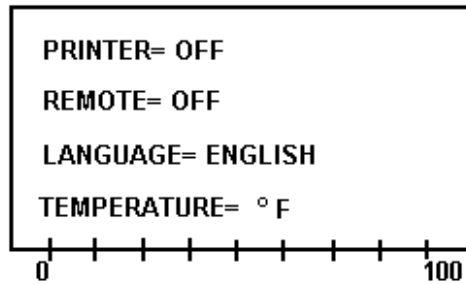

Use the **Up** and **Down** arrow keys, if necessary, to display the line showing the **Date** parameter.

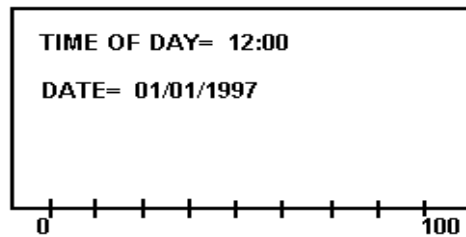

Press the **Line Select** key that corresponds to **Date**.

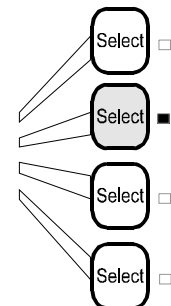
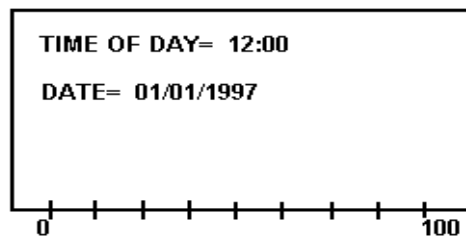

Use the numeric keys to enter the current date, using an American or European date format as appropriate. If you set English as the Language parameter, the system uses the American date format (MM/DD/YYYY). Otherwise, it uses the European format (DD/MM/YYYY).

TIME OF DAY= 12:00
DATE= 01/01/1997

0 100



Press the **Enter** key to store the value for **Date**, or press the **Clear** key to re-enter the date.

TIME OF DAY= 12:00
DATE= 01/01/1997

0 100

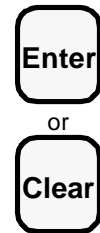

Press the **Setup** key to exit the **System Setup** menu. The **Setup** LED extinguishes.



System Setup - Time of Day

The Time of Day parameter affects the Time shown on the display and printed on the Reports (24-hour format only).

Take this action...

To get this result...

Press the **Setup** key to display the **System Setup** menu. Its LED lights.

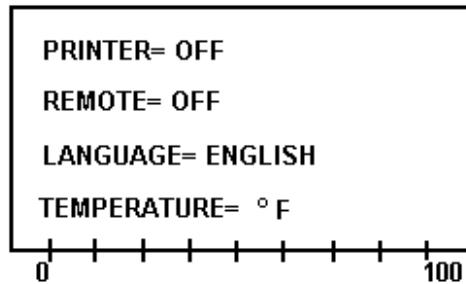

Use the **Up** and **Down** arrow keys, if necessary, to display the line showing the **Time of Day** parameter.

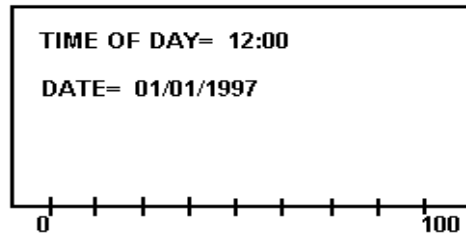

Press the **Line Select** key that corresponds to **Time of Day**.

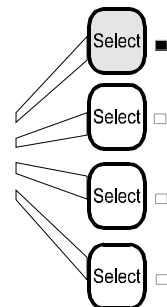
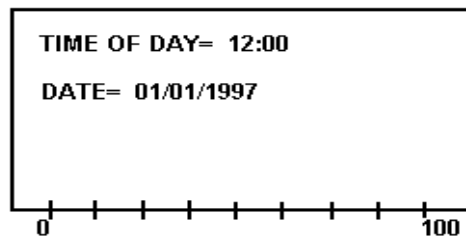

Use the numeric keys to enter the current time, based on a 24-hour clock.

TIME OF DAY= 12:00
DATE= 01/01/1997

0 | | | | | | | | | 100



Press the **Enter** key to store the value for **Time of Day**, or press the **Clear** key to re-enter the time.

TIME OF DAY= 12:00
DATE= 01/01/1997

0 | | | | | | | | | 100

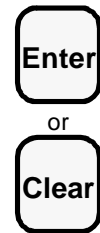

Press the **Setup** key to exit the **System Setup** menu. The **Setup** LED extinguishes.



System Setup - Temperature Units

The Temperature parameter affects whether the system uses Celsius or Fahrenheit units.

Take this action...

To get this result...

Press the **Setup** key to display the **System Setup** menu. Its LED lights.

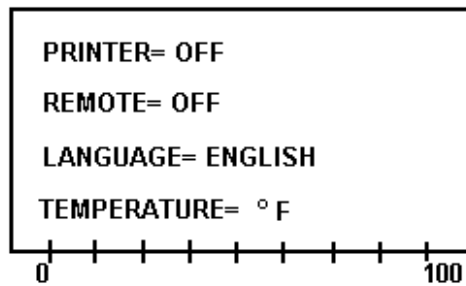

Use the **Up** and **Down** arrow keys, if necessary, to display the line showing the **Temperature** parameter.

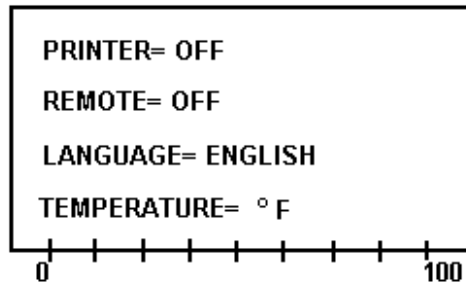

Press the **Line Select** key that corresponds to **Temperature**.

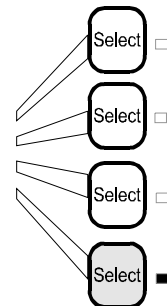
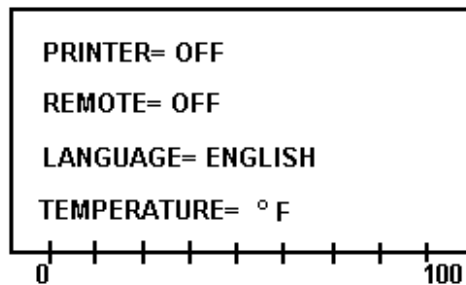

Press the same **Line Select** key again to toggle between the possible values for **Temperature** units: °F or °C.

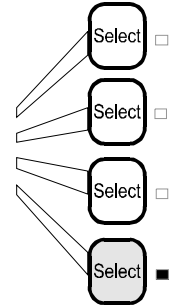
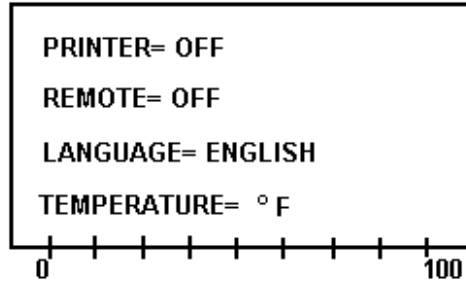

Press the **Enter** key to store the value for **Temperature** units.

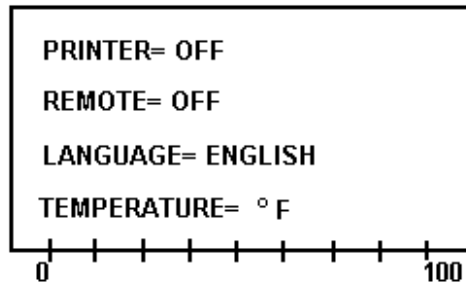

Press the **Setup** key to exit the **System Setup** menu. The **Setup** LED extinguishes.



System Setup - Printer

The Printer parameter enables or disables the ability to support a Printer.

Take this action...

To get this result...

Press the **Setup** key to display the **System Setup** menu. Its LED lights.

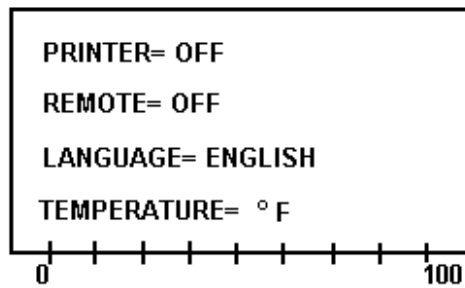

Use the **Up** and **Down** arrow keys, if necessary, to display the line showing the **Printer** parameter.

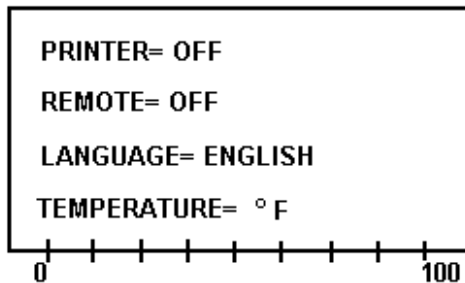

Press the **Line Select** key that corresponds to **Printer**.

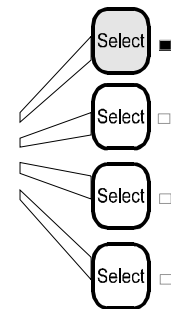
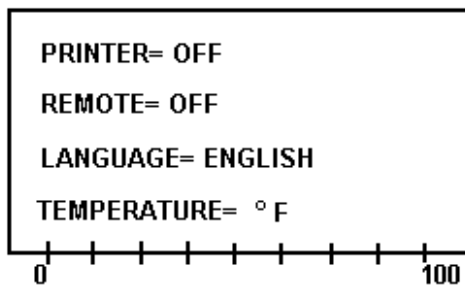

Press the same **Line Select** key to toggle between the two possible values for **Printer**: **On** if a printer will be enabled, or **Off** if it will be disabled.

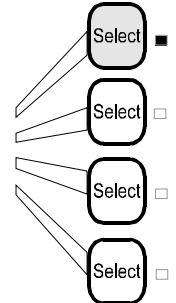
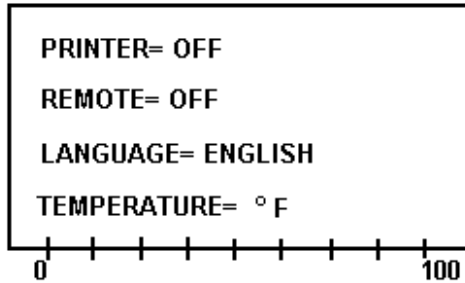

Press the **Enter** key to store the value for **Printer**.

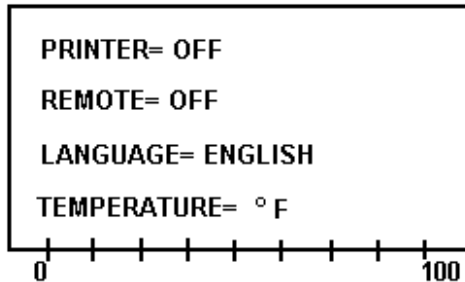

Press the **Setup** key to exit the **System Setup** menu. The **Setup** LED extinguishes.



System Setup - Printer Model

The Model parameter selects the printer model from several choices, when the Printer parameter is enabled.

Take this action...

To get this result...

Press the **Setup** key to display the **System Setup** menu. Its LED lights.

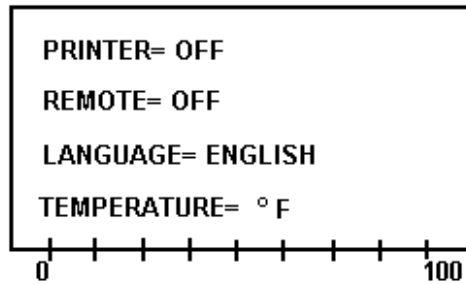

Use the **Up** and **Down** arrow keys, if necessary, to display the line showing the **Model** parameter.

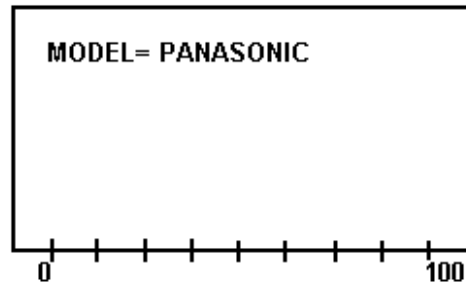

Press the **Line Select** key that corresponds to **Model**.

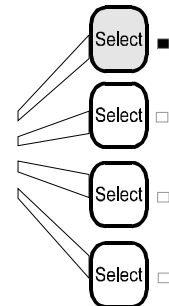
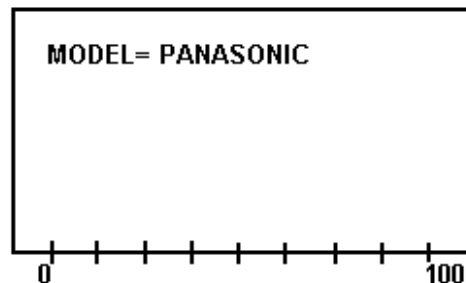

Press the same **Line Select** key again to toggle among the possible values for your printer **Model**: **Panasonic**, **Epson**, or **IBM**.

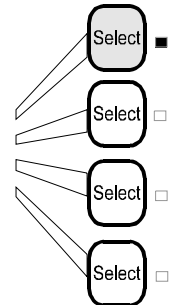
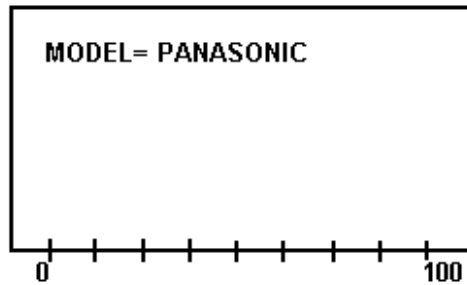

Press the **Enter** key to store the value for **Model**.

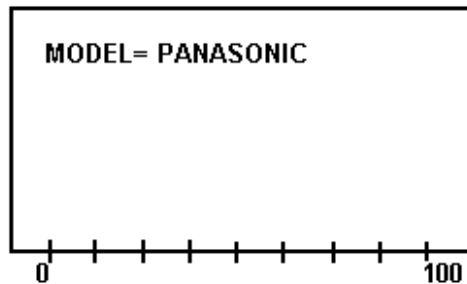

Press the **Setup** key to exit the **System Setup** menu. The **Setup** LED extinguishes.



System Setup - Reports

The Reports parameter enables or disables the Reports option to your Printer and/or your Remote Computer or Terminal.

Take this action...

To get this result...

Press the **Setup** key to display the **System Setup** menu. Its LED lights.

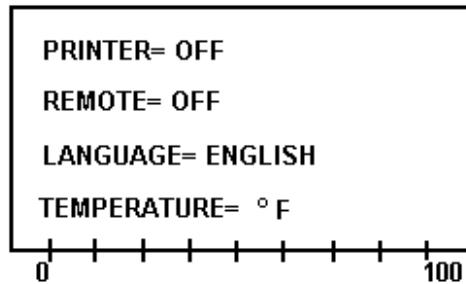

Use the **Up** and **Down** arrow keys, if necessary, to display the line showing the **Reports** parameter.

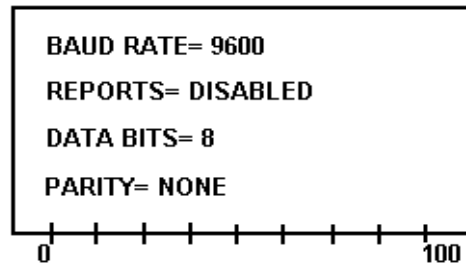

Press the **Line Select** key that corresponds to **Reports**.

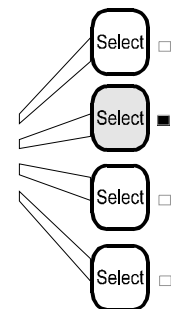
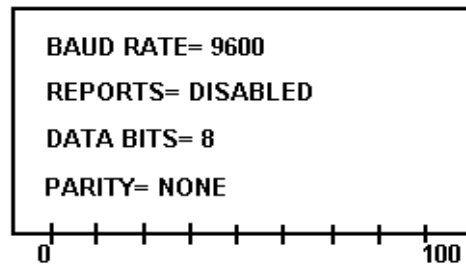

Press the same **Line Select** key again to toggle between the possible values for **Reports: Enabled** or **Disabled**.

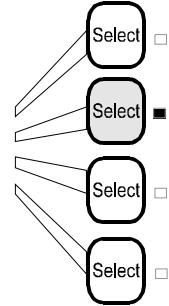
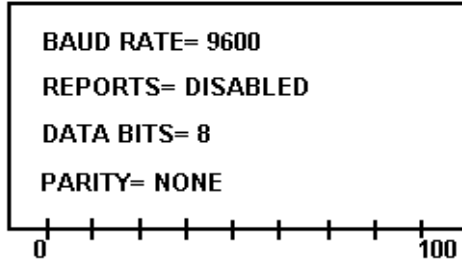

Press the **Enter** key to store the value for **Reports**.

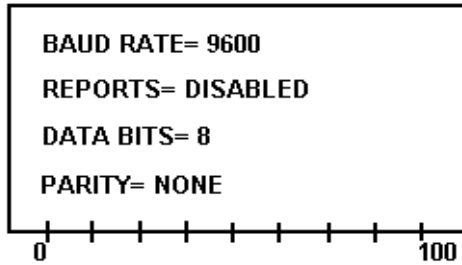

Press the **Setup** key to exit the **System Setup** menu. The **Setup** LED extinguishes.



6.4 Entering Operation Parameters

You can enter Operation parameters through the keypad or through the remote terminal, if the terminal is enabled in the System Setup menu. Only the Amplitude value (using the Amplitude knob on the side of the chassis) may be changed when an experiment is running.

When the System is in the Ready mode (e.g. after power-up or after a test or experiment is performed) it displays the first page of the Parameter Entry menu. In the Parameter Entry menu, you can enter parameters for your test or experiment. When a Line Select key for a parameter is available and may be selected, its LED is lit.

Entering Parameters from the Keypad

When in the Ready mode, you can press any available **Line Select** key on the front panel to select a parameter for modification. There are a total of two (2) pages of parameters; use the Arrow Up or Arrow Down keys to see more parameter choices on the display.

Use the number keys to key in a parameter value, and press **Enter** to store the value or accept the choice, or press **Clear** to clear a stored numeric entry or to disable a choice and then press **Enter** to store the cleared or disabled parameter value. The System will not accept parameter values that are out of the range of the system. Once the parameters have been changed and stored, the experiment is ready to run with the new values.

6.4.1 Presets

Once you have a set of parameters stored for a given experiment, you can save that setup as a Preset. Up to 20 Presets may be saved, using the Save and Recall functions described in the following sections. Presets are saved and recalled using a number, 01 to 20. Presets save all parameters for the setup except for the Amplitude parameter. Presets are saved until they are over-written or cleared, and are maintained in memory even if the system is turned off or unplugged.

6.4.2 Remote Terminal entry

The Remote Terminal may be used to change any of the operation parameters (except for Amplitude). Instructions and commands that you use to enter parameters from the remote terminal are described in *Section 6.5, Remote Computer or Terminal*, beginning on page 6-35.

Reviewing Parameters on the Remote Terminal

If you have disabled the front-panel keypad by sending a !KL from the remote terminal, only the **Start/Stop** and **Pause** keys are active. If both the keypad and the remote computer or terminal are active, the parameters displayed on the front panel will be similar to those described in this section, but any values you enter on the keypad will be updated at the remote computer or terminal only when you request them by issuing the Recall Parameters (!RP) command. See *Section 6.5, Remote Computer or Terminal*, beginning on page 6-35 for more information.

The Operation parameters that you can set from the keypad are described in the following table. Detailed steps for each parameter are described in the pages that follow.

Table 6-2: Operation Parameters

Parameter	Description	Valid Entries
Preset ID#	When you view a set of parameters that was saved using the Save function, Preset ID# contains the preset identification number under which the parameters were saved. The number is not available for entry. The Preset ID will be followed by an asterisk (*) if you change any of the parameters.	01 – 20
Time	The length of time the experiment should run, in hours, minutes and seconds.	0:00:01 – 9:59:59
Max. Temp.	This parameter is available only if a temperature probe is connected to the system. The temperature units (Fahrenheit or Celsius) are determined by the setting of the Temperature parameter, selected during System Setup. If no probe is connected, the value will display as TEMP OFF.	32.0° – 212.0°F or 0.0° – 100.0°C
Amplitude	The current Amplitude setting (manually set using the Amplitude control on the side of the unit). The amplitude affects the amount of power applied during the experiment.	10% minimum to 100% maximum
Pulse Temp	This parameter is available for entering the Pulse Temperature if a temperature probe is connected. Entering a value for this parameter puts the system in the Pulse/Pause mode. The temperature units (Fahrenheit or Celsius) are determined by the setting of the Temperature parameter, selected during System Setup. If a probe is not connected, the Pulse Temp value will be displayed as TEMP OFF.	32.0°F or 0.0°C to 3° below Max. Temp. parameter
Pulse On	In Pulse mode, the length of time in tenths of seconds that ultrasonics will be On	0.1 to 59.9 seconds
Pulse Off	In Pulse mode, the length of time in tenths of seconds that ultrasonics will be Off	0.1 to 59.9 seconds

Parameter Entry - Time

The Time parameter, if used, identifies the time duration of an experiment, in hours, minutes and seconds, during which ultrasonic vibrations are active and are putting energy into your experiment. The experiment will stop when the Time entry has elapsed. Time may also be used as a Limit.

CAUTION

j

Setting the *MAX TEMP* and *TIME* parameters together can cause the system to operate in a temperature-limiting fashion, which can cause ultrasonics to be suspended briefly, and then reactivate to continue a process cycle without warning.

Do not handle the Horn or Converter if using *MAX TEMP* and *TIME* in the Temperature Mode, and ensure the process cycle is Stopped before touching the Horn, or injury could occur.

Take this action...

To get this result...

Use the **Up** and **Down** arrow keys, if necessary, to display the line showing the **Time** parameter.

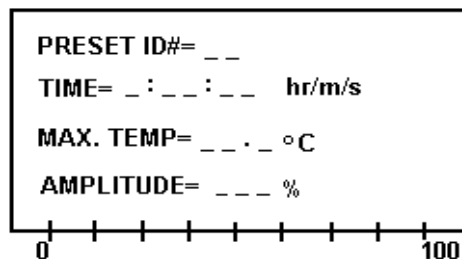

Press the **Line Select** key that corresponds to **Time**.

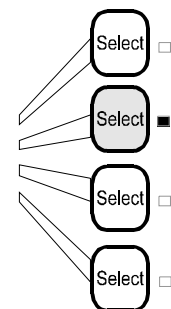
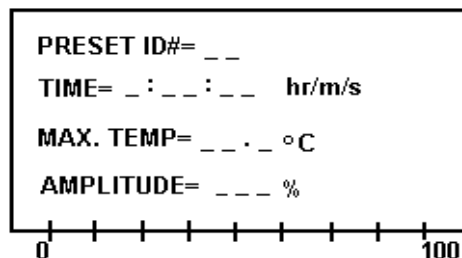



Use the numeric keys to enter a value for **Time**, how long you want the experiment to run.

PRESET ID#= __
TIME= _:__:__ hr/m/s
MAX. TEMP= __. __ °C
AMPLITUDE= ____ %

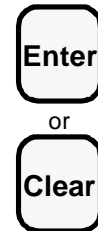

Press the **Enter** key to store the value for **Time**, or press the **Clear** key to re-enter the time.

PRESET ID#= __
TIME= _:__:__ hr/m/s
MAX. TEMP= __. __ °C
AMPLITUDE= ____ %



i

NOTE

If using the Time parameter as a limit in Pulsed Mode, the elapsed time will be greater than the Time parameter value, since the Time value is the duration that ultrasonic vibrations are active (the 'Pulse On' time) and does not include the 'Pulse Off' time.

Parameter Entry - Maximum Temperature

The Maximum Temperature parameter, if used, identifies the maximum temperature allowed in the experiment. Maximum Temperature may be used as a Limit for all modes except Pulse/Pause Mode.

CAUTION

j

Setting the *MAX TEMP* and *TIME* parameters together can cause the system to operate in a temperature-limiting fashion, which can cause ultrasonics to be suspended briefly, and then reactivate to continue a process cycle without warning.

Do not handle the Horn or Converter if using *MAX TEMP* and *TIME* in the Temperature Mode, and ensure the process cycle is Stopped before touching the Horn, or injury could occur.

If used with the Pulse/Pause mode or using Maximum Temperature and Time parameters together, Maximum Temperature sets the upper temperature parameter of these modes, at which point the experiment will pause to allow cooling, but does not cause the experiment to Stop.

Take this action...

To get this result...

Use the **Up** and **Down** arrow keys, if necessary, to display the line showing the **Max. Temp** parameter.

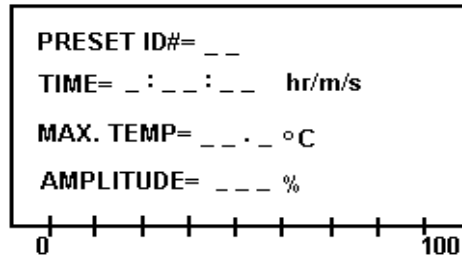

Press the **Line Select** key that corresponds to **Max. Temp**.

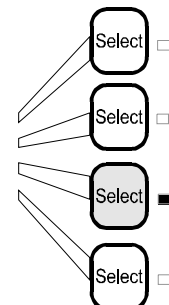
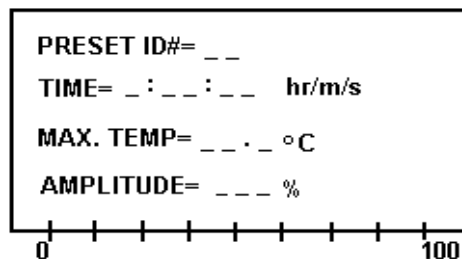

Use the numeric keys to enter the value for **Max. Temp.**

PRESET ID#= __
TIME= _:__:__ hr/m/s
MAX. TEMP= __. __ °C
AMPLITUDE= ____ %

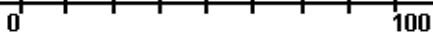

Press the **Enter** key to store the value for **Max Temp**, or press the **Clear** key to correct and re-enter the temperature.

PRESET ID#= __
TIME= _:__:__ hr/m/s
MAX. TEMP= __. __ °C
AMPLITUDE= ____ %

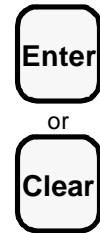
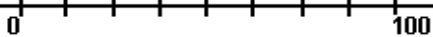

Parameter Entry - Pulse On and Pulse Off

The Pulse On and Pulse Off parameters identify the duration of the repeating Ultrasonics On Pulse and of the period in between On Pulses, respectively, used in the Pulse mode and Pulse/Pause mode.

Take this action...

To get this result...

Use the **Up** and **Down** arrow keys, if necessary, to display the line showing the **Pulse On** parameter.

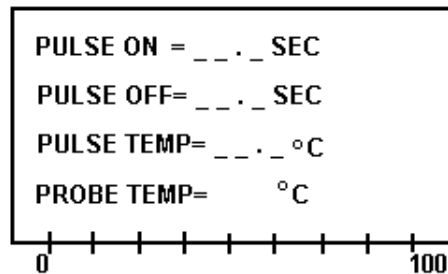

Press the **Line Select** key that corresponds to **Pulse On**.

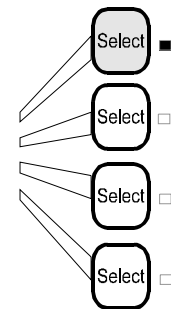
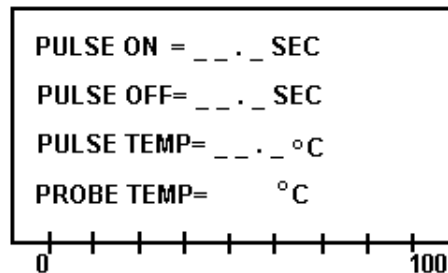

Use the numeric keys to enter the **Pulse On** time, in tenths of seconds, that the ultrasonic pulse will be on.

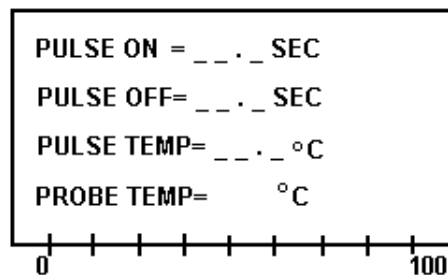

Press the **Enter** key to store the value for **Pulse On**, or press the **Clear** key to re-enter the value.

PULSE ON =	__ . __	SEC
PULSE OFF=	__ . __	SEC
PULSE TEMP=	__ . __	°C
PROBE TEMP=		°C

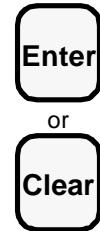

As soon as you have pressed **Enter** to store the **Pulse On** value, the system moves to the **Pulse Off** parameter line.

Use the **numeric keys** to enter the **Pulse Off** time, in tenths of seconds.

PULSE ON =	__ . __	SEC
PULSE OFF=	__ . __	SEC
PULSE TEMP=	__ . __	°C
PROBE TEMP=		°C



Press the **Enter** key to store the value for **Pulse Off**, or press the **Clear** key to re-enter the value.

PULSE ON =	__ . __	SEC
PULSE OFF=	__ . __	SEC
PULSE TEMP=	__ . __	°C
PROBE TEMP=		°C

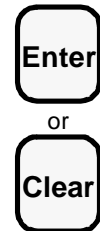

i

NOTE

A shortcut tip: If you **Clear** either Pulse time parameter and press **Enter**, both values will be cleared. You do not need to Clear both parameters.

Parameter Entry - Pulse Temperature

The Pulse Temperature is the lower temperature parameter of the **Pulse/Pause mode** temperature range. Entering a value for the Pulse Temperature enables the Pulse/Pause mode; clearing this value disables this mode.

CAUTION

j

Setting the *PULSE TEMP* parameter to a numeric value will activate the Pulse/Pause Mode process. This can cause the system to operate in an On and Off fashion, which can cause the ultrasonics to be suspended for a period of time, and then reactivate to continue a process cycle without warning.

Do not handle the Horn or Converter if the Pulse/Pause Mode is activated and running, and ensure the process cycle is Stopped before touching the Horn, or injury could occur.

Take this action...

To get this result...

Use the **Up** and **Down** arrow keys, if necessary, to display the line showing the **Pulse Temp** parameter.

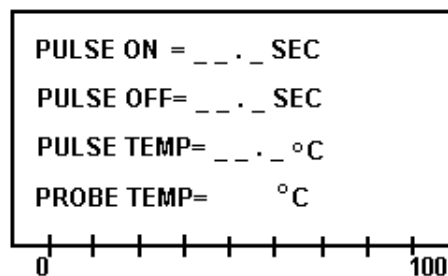

Press the **Line Select** key that corresponds to **Pulse Temp**.

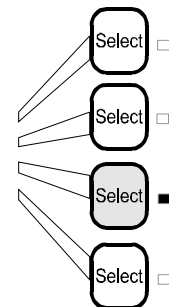
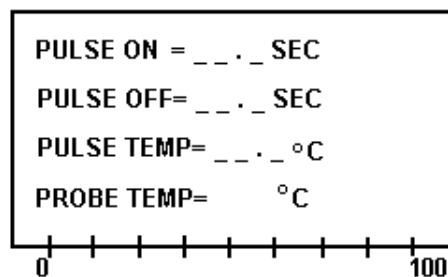

Use the numeric keys to enter the **Pulse Temp.**

PULSE ON = _ . _ SEC

PULSE OFF= _ . _ SEC

PULSE TEMP= _ . _ °C

PROBE TEMP= °C

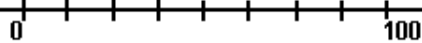



Press the **Enter** key to store the value for **Pulse Temp.**, or press the **Clear** key to correct and re-enter the value.

PULSE ON = _ . _ SEC

PULSE OFF= _ . _ SEC

PULSE TEMP= _ . _ °C

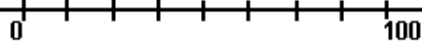
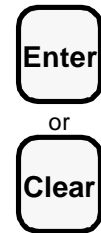
PROBE TEMP= °C

i

NOTE

The PROBE TEMP value is a display of the temperature of the optional Temperature Probe. If the Temperature Probe is not connected, the display will show TEMP OFF instead.

6.5 Remote Computer or Terminal

For your remote computer or terminal to be active, you must enable it in the System Setup menu as described in *System Setup - Remote Computer / Terminal* on page 6-38. If you want to use *only* the remote device to control operation of the Digital Sonifier, you can lock out the Sonifier's keypad by issuing a command from the terminal, as described in Table 6-3: *'Remote Terminal Commands'* on page 6-36.

You can enter Operation parameters through the remote computer or terminal, but you must use the keypad to enter System Setup parameters. You can use your terminal or computer to direct the system to start, stop, or pause the experiment, to send a report to the printer or terminal, or to display the current parameters.

i **NOTE**
To quickly exit from the Remote Terminal Mode, turn the Sonifier's power switch off and then back on. The system defaults to the front-panel control mode when it is first powered up.

The commands that you can issue from the remote computer or terminal are described in Table 6-3: *'Remote Terminal Commands'* on page 6-36. Use your remote computer or terminal's keypad to key in alphanumeric values, and use your remote computer or terminal's **Enter** or **Return** key to store the values. All remote terminal commands begin with an exclamation point. Refer to Table 6-2: *'Operation Parameters'* on page 6-26, for valid formats and limits for the parameters.

To Enter a parameter value using a Remote Computer or Terminal

Step	Action
1	Type the remote terminal command that corresponds to the parameter whose value you want to change. Remote terminal commands are described in Table 6-3: <i>'Remote Terminal Commands'</i> on page 6-36. The remote computer or terminal displays a data entry field for the parameter.
2	Enter the new value on the terminal following the format described on page 6-26.
3	Press Enter on your remote computer or terminal. The system checks the value for the proper format and range for the parameter. If the value you entered is valid, the system accepts it, displays 'OK' on the remote computer or terminal, and updates the LCD display on the unit's control panel if the active page contains that parameter. If the value is invalid, the system displays an error message.
4	To Clear a value using the remote computer or terminal, enter the parameter command as described in Step 3 above, except when prompted to enter a value, do NOT enter any value but instead simply press the Enter or Return key on your terminal; the existing value will then be cleared, the system displays 'OK' on the remote computer or terminal and updates the LCD display to show that parameter as "OFF" or no value.

Table 6-3: Remote Terminal Commands

Command	Terminal Displays	User / System Action
!T	TIME=	Type a value for the time, and press Enter on your remote computer or terminal.
!MT	MAX TEMP=	Type the maximum temperature, and press Enter on your remote computer or terminal.
!PO	PULSE ON=	Type the time period when power will be on, and press Enter on your remote computer or terminal.
!POF	PULSE OFF=	Type the time period when power will be off, and press Enter on your remote computer or terminal.
!PPT	PULSE TEMP=	Type the Pulse Temperature, and press Enter on your remote computer or terminal.
!SV	PRESET ID#	Type the identifying number under which you want to save the preset parameter values, and press Enter on your remote computer or terminal.
!R	PRESET ID#	Type the preset ID number for the saved set of parameters you want to use, and press Enter on your remote computer or terminal.
!RP	List of parameters	The system displays all the current parameters on the remote computer or terminal.
!S	Report	The system sends a report to the remote computer or terminal.
!P	N/A	The system sends a report to the printer.
!H	EXPERIMENT PAUSED	The experiment is currently paused. Issuing another pause command from the remote terminal will cause the experiment to resume, if the experiment is currently paused.
!TS	TUNING TEST PLEASE WAIT 2 SEC.	Ultrasonics are activated for a two-second test.
!KL	* KEYPAD DISABLED *	The keypad is disabled, or enabled if it was already disabled.
!ON	EXPERIMENT RUNNING (displayed every 5 seconds)	The experiment is running from a remote command.
!OFF	EXPERIMENT STOPPED	The experiment has been stopped.

System Setup - Remote Computer / Terminal

The Remote parameter enables or disables support for a customer-provided Remote Computer or Terminal.

Take this action...

To get this result...

Press the **Setup** key to display the **System Setup** menu. Its LED lights.

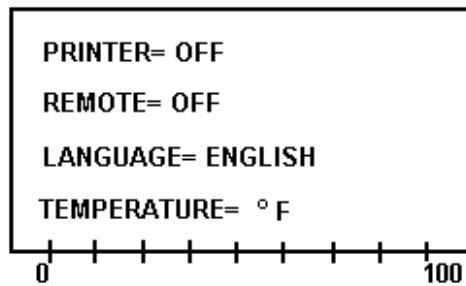

Use the **Up** and **Down** arrow keys, if necessary, to display the line showing the **Remote** parameter.

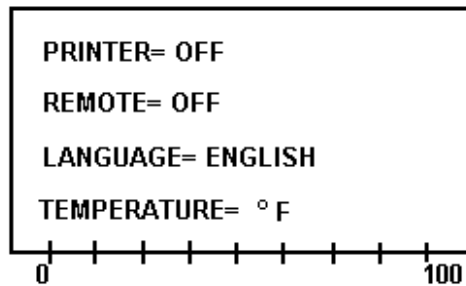

Press the **Line Select** key that corresponds to **Remote**.

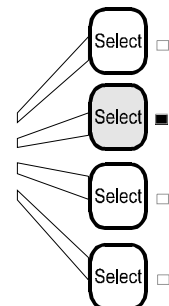
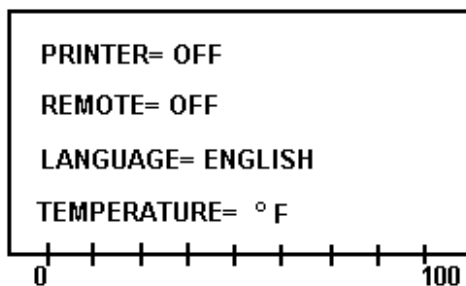

Press the same **Line Select** key to toggle between the two possible values for Remote: **On** if a remote computer or terminal will be enabled, **Off** if it will be disabled.

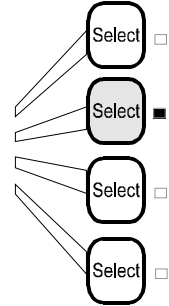
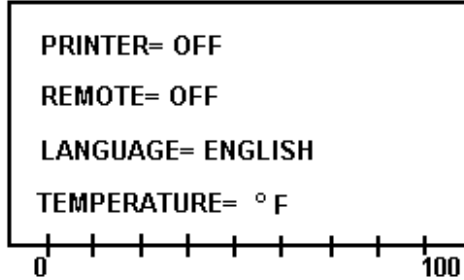

Press the **Enter** key to store the value for **Remote**.

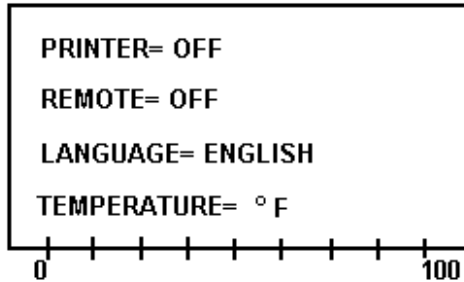

Press the **Setup** key to exit the **System Setup** menu. The **Setup** LED extinguishes.



System Setup - Baud Rate

The Baud Rate parameter identifies the communication rate of the Serial Port used for the remote computer or terminal.

i **NOTE**
 The Baud Rate parameter configures the data communications rate for the optional remote computer or terminal. The Data Bits format and Parity parameters are non-adjustable.

Take this action...

To get this result...

Press the **Setup** key to display the **System Setup** menu. Its LED lights.

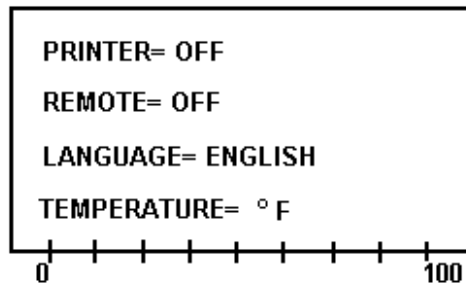

Use the **Up** and **Down** arrow keys, if necessary, to display the line showing the **Baud Rate** parameter.

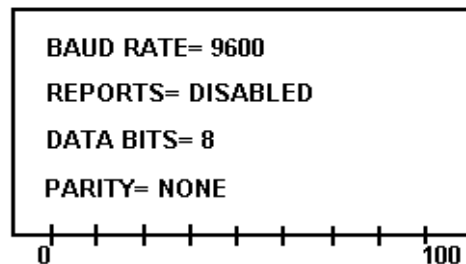

Press the **Line Select** key that corresponds to **Baud Rate**.

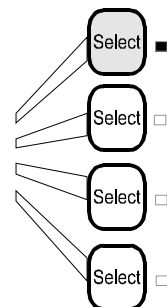
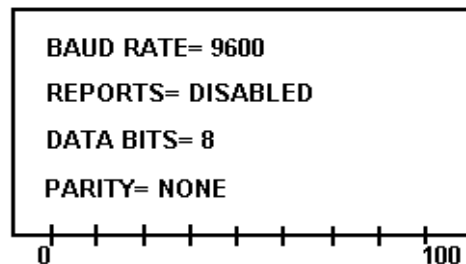

Press the same **Line Select** key again to toggle among the possible values for **Baud Rate**: **1200**, **2400**, **9600**, or **19200**.

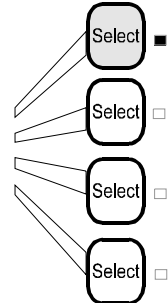
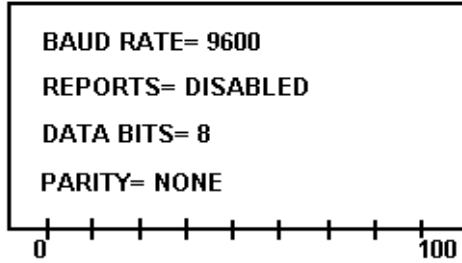

Press the **Enter** key to store the value for **Baud Rate**.

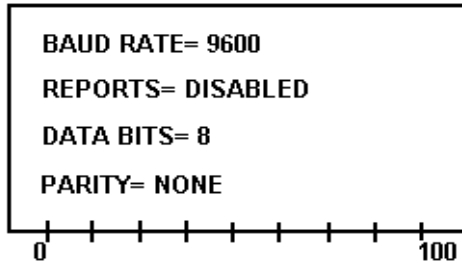

Press the **Setup** key to exit the **System Setup** menu. The **Setup** LED extinguishes.



6.6 Save and Recall Presets

The Save and Recall functions allow you to enter a set of Operation parameters and save them under a unique ID number. To repeat an experiment or test using the same set of parameters without having to re-enter them (with the exception of the Amplitude setting), you can use the ID number to recall the saved parameters.

To Save a set of parameters as a Preset, follow this procedure:

Step	Action to Save Presets
1	Press the Save key on the keypad, or type an !SV command from the remote computer or terminal. The system displays the Save To: entry screen.
2	Using the keypad, enter a value for the preset ID number. You can use values from 01 to 20.
3	Press Enter to save the value. The system displays a message asking you to confirm that you want to overwrite the existing preset (even if you chose an unused Preset ID). Press the appropriate Select key for Yes to replace the previous preset with the one you are setting and Save your Setup, or No to return to the previous screen and give the current preset a different ID number.

i **NOTE**
The system will always confirm the 'overwrite' procedure as a level of security for all presets, even if the user had not previously used that Preset ID.

To Recall a saved Preset, follow this procedure:

Step	Action to Recall a Saved Preset
1	Press the Recall key or type an !R command from the remote computer or terminal. The system displays the Recall entry screen.
2	Using the keypad or the number keys on your Remote Terminal or Computer, enter in the desired preset number.
3	Press Enter . The system reloads the preset information to memory and is ready to run with those parameters. The system returns to the previous page of the screen.

6.7 Printing/Sending Reports

After an experiment, the system can produce a report showing the date and time of the experiment, the parameters in effect, and statistics for energy, power, amplitude, and temperature. The report data remains available until you start a new experiment, or until you change any System Setup parameters. Reports must be turned on in the Setup menu. If you want to run a report, you must do so *before* the next experiment is started and *before* you change any System Setup parameters. You can send the report to a printer or to the remote computer or terminal. The report has the following format:

TIME = XX:XX DATE = XX/XX/XXXX

PRESET ID# = *value*

TIME = *value*

MAX. TEMP = *value*

PULSE ON = *value*

PULSE OFF = *value*

PULSE TEMP = *value*

ENERGY = *energy delivered, in Joules*

PEAK POWER = *power delivered, in watts*

AMPLITUDE = *last amplitude %*

LAST TEMPERATURE READING = *temperature* TIME = *elapsed time*

HIGHEST TEMPERATURE = *temperature* TIME = *elapsed time*

6.8 Displays During the Experiment

Runtime Displays

While the experiment is in progress, the system shows certain runtime data on the LCD display and on the remote computer or terminal if one is enabled. The data is refreshed on the display every second. The Start/Stop LED on the front panel also indicates that an experiment is running.

The following front panel displays will be seen when the system is running an experiment:

The first page of the runtime display. Note the bargraph display on the bottom line.

If you wish you see the second page, press the Down Arrow button.

```

RUN TIME= 0:43:27
PROBE TEMP= 67.6°F
PULSE ON
.....
    
```



The second page of the runtime display.

If you wish to see the first page, press the Up Arrow button.

```

MAX. TEMP= 104.7°F
PULSE TEMP=___°F
TIME=_:_:__ hr/m/s
POWER=146 Watts
    
```



Start/Stop key and LED

The Start/Stop key is used to manually Stop an experiment at any time (even during Remote mode with the keypad locked). While the experiment cycle is running or active, the LED next to the Start/Stop button is lit. Normally, the Start/Stop key is used to Start or Stop an experiment from the front panel, but the front panel controls may be locked if using the Keypad Lock parameter from the remote computer or terminal. Pressing the Start/Stop key or !OFF command while an experiment is paused will end or stop the paused experiment.

Pause key and LED

The Pause key is used to manually Pause an experiment at any time (even during Remote mode with the keypad locked). When you pause operation by pressing the Pause key on the keypad or by typing an !H command through the remote computer or terminal, the display shows a message stating that operation has been paused, and the front panel **Pause** LED will be lit. The **Start/Stop** LED also remains lit while an experiment is paused. To resume operation, press the Pause key again or send another !H command.

Keypad Enabled

If the keypad is enabled, the Up and Down arrows, Start/Stop, and Pause keys are active, and the display shows the information described in the following table:

Table 6-4: Data Displayed During the Experiment when the Keypad is Enabled

Display	Description
RUN TIME	The elapsed time of the experiment, increasing from 0:00:00
PROBE TEMP	The temperature currently being read by the temperature probe, if one is connected
PULSE ON and PULSE OFF	If you entered Pulse On and Pulse Off times, shows PULSE ON when ultrasonics are active and PULSE OFF when ultrasonics are inactive
Power display bar graph	The current percentage of maximum power being used, represented as a bar graph. Displayed values are approximate, using 5% segments
MAX. TEMP	The maximum temperature that will be reached during the experiment, if you specified a Maximum Temperature parameter
PULSE TEMP	In Pulse/Pause mode, the temperature at which the system will begin calculating the Pulse/Pause ratio
TIME	The time limit for the experiment, if one was entered
POWER	The power, in watts, being consumed by the Horn at any moment. During a PULSE OFF period, the power goes to zero

Keypad Disabled

If the keypad is disabled, the LCD display on the front panel shows one of the following items:

- KEYPAD DISABLED message
- EXPERIMENT RUNNING message
- Power display bar graph

During the experiment, only the Start/Stop and Pause keys are active. When the experiment is finished, the EXPERIMENT RUNNING message changes to EXPERIMENT COMPLETED.

Remote Terminal Displays

If a remote computer or terminal is connected and active, the system displays the EXPERIMENT RUNNING message on the screen every five seconds while the experiment is running. See page 6-35 for more information about the Remote Terminal option and its commands.

6.9 Warning and Error Messages

When the system encounters an error condition, a message is displayed on the front panel of the Digital Sonifier unit and on the remote computer or terminal if one is enabled. If the keypad is in lockout mode, messages will appear only on the remote computer or terminal. The following table describes the possible error and warning messages, the conditions that cause them, and the actions you should take when they are displayed.

Table 6-5: Warning and Error Messages

Message	Cause	Take This Action
Value out of range	You entered a parameter value that was outside the parameter's limits.	Press Enter . The parameter becomes available so that you can re-enter a correct value. Refer to Table 6-1: 'System Setup Parameters' on page 6-9, and Table 6-2: 'Operation Parameters' on page 6-26, for the limits for specific parameters.
Are you sure you want to overwrite?	You tried to save a set of parameter values under a preset ID that is already in use.	To overwrite the existing values in the Pre-set ID, press Line Selector key #3. To enter a different preset ID, press Line Selector key #4. The previous screen is displayed for you to enter a different pre-set ID.
Printer error	You issued a print command, but there was no response from the printer.	Check that the printer is correctly connected and turned on. Check the Model parameter to see that the correct printer model has been set. Check that the Printer parameter is set to On.
	The system was turned on with the 'Printer = On' but with no printer connected.	
THE DATA FORMAT ENTERED FOR <i>parameter</i> IS INCORRECT! PLEASE ENTER AGAIN.	The parameter value that you entered was in the wrong format.	Enter the value in the correct format. Refer to Table 6-1: 'System Setup Parameters' on page 6-9, and Table 6-2: 'Operation Parameters' on page 6-26 for valid parameter formats.
INVALID COMMAND RECEIVED, PLEASE ENTER AGAIN.	You entered an invalid command through the remote computer or terminal.	Enter a valid command. Refer to Table 6-2: 'Operation Parameters' on page 6-26 for valid remote terminal commands.
THE SYSTEM COULD NOT INTERPRET THE LAST TRANSMISSION. PLEASE TRY SENDING AGAIN.	The system could not interpret the data that was sent from the remote computer or terminal.	Send the data again.

7 Maintenance

7.1	Maintenance and Troubleshooting	- - - - -	7-1
7.2	Reconditioning the Stack Interface	- - - - -	7-2
7.3	Troubleshooting Charts	- - - - -	7-5
7.4	Interconnect Diagram	- - - - -	7-9

7.1 Maintenance and Troubleshooting

The Digital Sonifier is a self-contained system that requires no internal servicing, except for a protective fuse, and there are no user serviceable parts inside the unit. The ultrasonic tooling (horns and tips) may require periodic inspection and maintenance to ensure optimum performance. The tooling components are subject to wear and may require replacement after a period of time, depending on the applications.

If you have a problem operating your unit, refer to Table 1: '*System Trouble Analysis Chart*' on page 7-7 to locate the symptom that most clearly describes your problem.

Tip Erosion

Horn tips can erode. Tip erosion is a side effect of the cavitation process that occurs when liquids are exposed to ultrasonic energy. The rate of erosion depends on the intensity of power applied, the corrosiveness of the liquid being treated, and the amount of use.

Periodically inspecting the tip will help you recognize erosion early. As erosion progresses, the color of the tip changes from its original polished appearance, first to light grey and then to dark grey. Concentric rings begin to appear, and finally the tip becomes rough and pitted, resulting in loss of power output. As it erodes, the tip can also introduce metal particles into the solution, causing it to darken or discolor.

Eventually, erosion may become significant, at which point the tip will require replacement.

Power Output Loss

There are several conditions that can cause a decrease in or loss of power output, including

- operating with a faulty power supply or poor electrical connection
- operating with a loose horn-converter connection, and
- operating with a cracked or corroded horn/tip assembly.

If your unit indicates a decrease in power output, first check the Converter Cable connections, then take the following steps to ensure that the horn/tip assembly is not loose or cracked or corroded.

Fretting corrosion refers to a black, crusty build-up, resulting from friction between metal parts that appears on the mating metal surfaces. Corrosion can reduce or alter system performance. Examine all mating surfaces (microtip to converter, disruptor to converter, tip to horn) and wipe the surfaces clean with a clean cloth or paper towel.

The 250/450 Sonifier does not require tuning. Tuning is done in the factory and cannot be performed by the operator.

7.2 Reconditioning the Stack Interface

Ultrasonic system components work most efficiently when the mating surfaces of the Converter-and-Horn combination (also called a “Stack”) are flat, in solid contact, and free from fretting corrosion. Fretting corrosion refers to a black, crusty build-up, resulting from friction between metal parts, that appears on the Stack mating surfaces. Poor contact between mating surfaces wastes power output, makes tuning difficult, increases noise and heat, and may cause damage to the converter.

7.2.1 Refacing the Mating Surfaces

NOTE
i Never clean the Converter or Horn mating surfaces with a buffing wheel.

1. Disassemble the Converter / Horn Stack and wipe the mating surfaces with a clean cloth or paper towel.
2. Examine all mating surfaces. If any mating surface shows corrosion or a hard, dark deposit, recondition it.
3. If necessary, remove the threaded stud from the part.
4. Tape a clean sheet of #400 (or finer) grit emery cloth to a clean, smooth, flat surface (such as a sheet of plate glass).

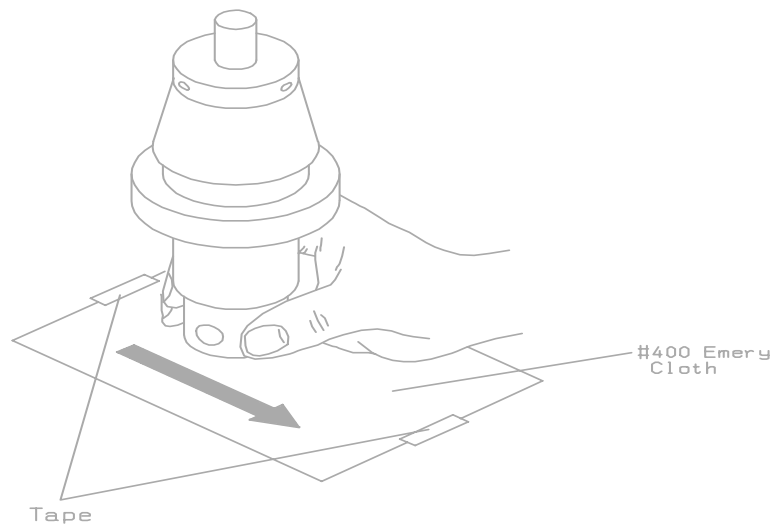

NOTE
i Be careful to avoid tilting the part and losing flatness of the surface. Doing so may make the system inoperative, due to improper mating surfaces.

Lapping Procedure

5. Holding the part to recondition, place the interface surface on the emery cloth. Grasp the part at the lower end, with your thumb over the spanner-wrench hole, and lap the part in a straight line across the emery cloth.

i **NOTE**
Do not apply downward pressure. The weight of the part alone provides sufficient pressure.

6. Rotate the part 120 degrees (1/3) to the next hole.
7. Stroke the part an equal number of times at each rotation (2 or 3).
8. Pick up the part and lap it once or twice in the same direction.
9. Rotate the part 120 degrees, placing your thumb over the spanner-wrench hole, and lap the part the same number of times as described above.
10. Rotate the part another 120 degrees to the next spanner-wrench hole, and repeat the lapping procedure.

Re-examine the mating surface. If necessary, repeat steps 5 through 10 until you remove most of the contaminant. This should not require more than two to three complete rotations for an aluminum horn or booster; a titanium component may require more rotations.

7.2.2 Horn Tip Cleaning

Take the following steps to clean the horn's tip threads:

1. If the horn has a replaceable tip, remove it and clean its threads in alcohol.
2. Swab out the end of the horn threads with a cotton swab and alcohol.
3. Make sure both the horn and the tip are clean and completely dry before you reassemble them.

Refer to the Tip installation procedures for information on tightening the Tips. This is found in *Section 4.4, Assembling the Equipment*, beginning on page 4-9.

4. Use a spanner wrench on the horn and an open-end wrench on the tip to install the tip using the following torque specifications:
 - 1/4-20 — tighten at 90-inch-lbs/10.16 Newton-meters
 - 3/8-24 — tighten at 180 inch-lbs/20.33 Newton-meters

7.2.3 Stud Reinsertion

The Stud is intended to be a use-only-once part, as it has knurls on its end which ‘bite’ into the relatively softer horn material. The studs are also specially designed to withstand ultrasonic stresses. If you must temporarily re-use a used stud, especially with an Aluminum horn, it is very important to clean the threads and the horn of the previous shavings.

1. Using a file card or wire brush, clean any chips from the knurled end of the stud.
2. Using a clean cloth or towel, clean the threaded hole.
3. Examine the knurled end of the stud. If worn, replace the stud. Examine the stud and threaded hole for stripped threads. Do not use a damaged ultrasonic horn or converter.

i **NOTE**
Threaded studs cannot be re-used in titanium horns.

4. Clean the stud and the threaded hole before reinserting it.
5. Apply one drop of Loctite to the stud and insert it into the horn.
6. Retighten the stud. Use the following torque specifications:

Stud Size	Torque Specification	Stud EDP number
3/8-24 x 11/4 in	290 in lbs/33 Nm	100-098-121
3/8-24 x 11/2 in	290 in lbs/33 Nm	100-098-120
1/2-20 x 11/4 in	450 in lbs/51 Nm	100-098-370
1/2-20 x 11/2 in	450 in lbs/51 Nm	100-098-123

After the Stud has been reinserted, you can reassemble the Horn to the Converter. Follow the same procedure as found in the Installation section of this manual. See *Section 4.4, Assembling the Equipment*, beginning on page 4-9.

7.3 Troubleshooting Charts

Use the following troubleshooting charts for possible problem conditions and resolutions. The charts are based on the assumption that the proper setup and operation instructions have been followed and/or the system was working and then developed a problem.

Table 1: System Trouble Analysis Chart

Symptom	Probable Cause	Corrective Action
Main power fuse fails or circuit breaker trips when system is plugged into electrical outlet.	• Cordset has failed	• Replace cordset
	• Power Switch has failed. • Line filter has failed.	• Return for repair
Display screen does not appear when unit is turned on. Fan does not operate.	• System is unplugged or main power is missing	• Correct power problem
	• Unit fuse has blown (it should not under normal conditions)	• Replace fuse
	• Cordset has failed	• Replace cordset
	• Power Switch has failed • Line filter has failed • Unit failed due to connection to incorrect input voltage	• Return for repair
Fan does not operate when system is turned on. Display screen appears.	• Fan motor has failed	• Return for repair
Fuse fails when system is turned on.	• Fuse is under-rated • Mains Voltage is incorrect • Fan motor has failed • Power supply module has failed • Unit failed due to connection to incorrect input voltage	• Verify voltage source is correct. Damage may occur if connected to wrong voltage source • Replace fuse with correct value and retry; or return for repair
Ultrasonic power is not delivered to the horn.	• Ultrasonic power supply module has failed • Digital controls have failed	• Return for repair
Unusual noise from Horn when ultrasonics are on	• Horn or Tip is loose, or it is contacting a solid object	• Reposition horn • Remove, examine, and clean tip; reinstall tip
	• Horn or tip has failed	• Replace horn or tip

Table 1: System Trouble Analysis Chart

Symptom	Probable Cause	Corrective Action
Ultrasonic power is absent or inconsistent	<ul style="list-style-type: none"> Foreign material is between horn surface and replaceable tip. If horn is hot to the touch, problem may exist with corroded tip-to-horn interface 	<ul style="list-style-type: none"> Remove, examine, and clean tip; reinstall tip Replace tip if corrosion is excessive
	<ul style="list-style-type: none"> If used with a Treatment Chamber, horn tip is not immersed adequately 	<ul style="list-style-type: none"> Verify the Treatment Chamber setup, adjust as needed
	<ul style="list-style-type: none"> Tip is loose or worn out Horn is loose or has failed 	<ul style="list-style-type: none"> Tighten or replace defective tip or horn
	<ul style="list-style-type: none"> Horn stud is loose or has failed 	<ul style="list-style-type: none"> Loose or broken studs must be replaced Replace defective horn
	<ul style="list-style-type: none"> Converter cable connection is loose or has failed 	<ul style="list-style-type: none"> Tighten connector to Converter Return unit for repair if cable has failed
	<ul style="list-style-type: none"> Converter has failed 	<ul style="list-style-type: none"> Replace defective Converter, return for repair.
	<ul style="list-style-type: none"> Microtip is loose or missing 	<ul style="list-style-type: none"> Clean horn and install microtip
	<ul style="list-style-type: none"> Power supply or controls have failed 	<ul style="list-style-type: none"> Return for repair
Digital Sonifier operates continuously but does not operate in Pulsed mode	<ul style="list-style-type: none"> Digital controls have failed 	<ul style="list-style-type: none"> Return for repair
No Temperature reading, or inaccurate Temperature value displayed	<ul style="list-style-type: none"> Temperature Probe is not connected 	<ul style="list-style-type: none"> Plug Probe into unit
	<ul style="list-style-type: none"> Temperature Probe has failed 	<ul style="list-style-type: none"> Replace Temperature Probe
	<ul style="list-style-type: none"> Digital Controls have failed 	<ul style="list-style-type: none"> Return unit for repair
Slight electric shock when touching a metal part of the system or lab equipment contacting the system	<ul style="list-style-type: none"> System is not properly grounded 	<ul style="list-style-type: none"> Correct electrical ground to system
	<ul style="list-style-type: none"> Cordset has failed or had Ground lead removed 	<ul style="list-style-type: none"> replace cordset

Table 1: System Trouble Analysis Chart

Symptom	Probable Cause	Corrective Action
Printer does not print a report upon request	<ul style="list-style-type: none"> • A Setup parameter has been changed • No report data stored in buffer since last report 	<ul style="list-style-type: none"> • Run at least one cycle to capture report data
	<ul style="list-style-type: none"> • Reports not enabled in Setup 	<ul style="list-style-type: none"> • enable Reports in Setup; run at least one cycle to capture new report data
	<ul style="list-style-type: none"> • Printer is not set to "On" in Setup Parameters 	<ul style="list-style-type: none"> • enable Printer in Setup; run at least one cycle to capture new report data
	<ul style="list-style-type: none"> • Printer cable is not connected, or printer is 'offline' 	<ul style="list-style-type: none"> • Correct printer connections and ready status
	<ul style="list-style-type: none"> • Printer has failed 	<ul style="list-style-type: none"> • Fix or replace printer
	<ul style="list-style-type: none"> • Digital Controls have failed 	<ul style="list-style-type: none"> • Return unit for repair
	<ul style="list-style-type: none"> • Printer is not compatible 	<ul style="list-style-type: none"> • Use a compatible dot-matrix printer
Remote Terminal is not communicating	<ul style="list-style-type: none"> • Remote Terminal is not set to On in Setup 	<ul style="list-style-type: none"> • enable Remote Terminal in Setup; run at least one cycle to capture new report data
	<ul style="list-style-type: none"> • incorrect or faulty RS-232 cable is used. 	<ul style="list-style-type: none"> • verify, see <i>Section 4.6.2, Remote Terminal Connection</i>, on page 4-14.
	<ul style="list-style-type: none"> • Baud Rates do not match between the system and the Remote Terminal 	<ul style="list-style-type: none"> • set Baud Rate in Setup; run at least one cycle to capture new report data
	<ul style="list-style-type: none"> • Terminal or computer's communication settings are not set up properly 	<ul style="list-style-type: none"> • set up the communication settings to match the Sonifier's parameters
User I/O signals are not working correctly	<ul style="list-style-type: none"> • User I/O is not configured correctly 	<ul style="list-style-type: none"> • Verify and correct connections - See <i>Section 4.6.6, User I/O Connection</i>, beginning on page 4-15
	<ul style="list-style-type: none"> • customer-provided User I/O components have failed or are no longer functioning 	
	<ul style="list-style-type: none"> • Outputs of User I/O failed 	<ul style="list-style-type: none"> • Return unit for repair

7.4 Interconnect Diagram

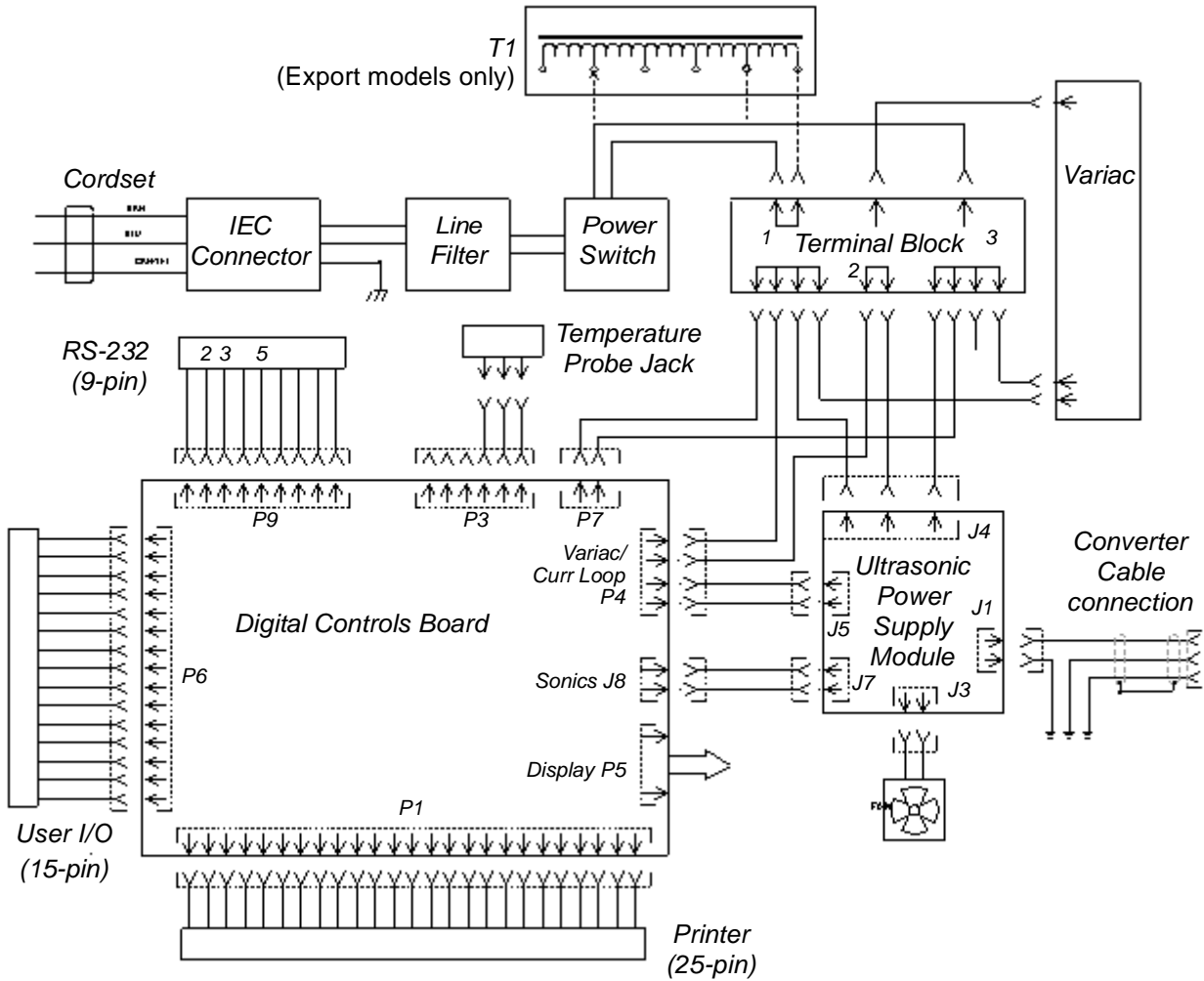

For Your Notes

APPENDIX A: Application Information

Operating Considerations

The following sections discuss operating techniques under varying conditions.

Limiting Temperature Rise

An important objective in ultrasonic emulsification is to keep processed samples cool. Selection of the proper processing vessel and cooling bath resolves most heating problems. While any type of vessel can be used to hold the sample, the shape of the vessel is determined primarily by the volume to be processed. For small volumes, choose the smallest diameter vessel that allows the probe to be inserted without touching the sides of the vessel. This minimized diameter raises the height of the liquid, exposing more surface area to the cooling bath for more effective heat transfer.

Based on heat transfer characteristics, the following vessel materials are recommended, listed in decreasing order of heat conductivity:

1. Aluminum
2. Stainless steel
3. Thin-wall glass
4. Thick-wall glass
5. Plastic

i **NOTE**
Plastic vessels are not recommended unless the sample being processed will be unaffected by heat or unless ultrasonic treatment is pulsed.

Immersing the processing vessel in a simple ice-water bath (0°C) provides sufficient cooling for larger sample volumes, if required treatment times are short. If temperature rise is too great with this method, consider using the following alternative baths:

- Ice-salt (-6°C)
- Ice-alcohol (-14°C)
- Dry ice-alcohol-water (-30° to -40°C)

i **NOTE**
All baths need a magnetic stirrer.

For smaller volumes with less than 30 seconds treatment time, an ice-water bath is sufficient. For longer periods, especially when high power is required, a lower temperature bath is required.

Vessel Capacity and Speed of Temperature Rise

The smaller the volume, the more difficult the cooling procedure becomes. For example, using any given power input, to treat 5 ml for a long period would require a cooling bath of approximately -35°C to maintain the sample at or below 5°C. In comparison, the processing of 200 ml would require a cooling bath of only 0°C to maintain the sample temperature.

Table 2 shows typical temperature rises for sample sizes of 25 ml and 100 ml, using a 250 Digital Sonifier. A polyethylene container was used, with a 1/2 inch (12.7 mm) diameter probe with a probe depth of 1/2 inch (12.7 mm) and a starting temperature of 25°C. "Average Difference" was the average difference among duplicate runs.

Table 1: Temperature Rise Variations

Sample Size	25 ml			100 ml		
	30	70	100	30	70	100
Amplitude Setting (%)						
Seconds						
30	30.0°	35.0°	42.0°	26.5°	27.5°	29.3°
60	34.0°	45.0°	55/6°	27.5°	30.3°	33.5°
120	42.0°	61.0°	78.0°	30.0°	35.0°	41.3°
180	48.5°	74.0°	90.0°	32.0°	39.3°	48.0°
240	54.5°	82.5°	95.0°	34.0°	44.0°	54.5°
300	60.0°	88.0°	95.0°	36.0°	48.0°	60.0°
Average Difference	±0.7°	±0.4°	±0.4°	±0°	±0.2°	±1.6°

Minimizing Undesirable Factors

Some factors may be detrimental to enzyme or biological activity and can reduce the effectiveness of ultrasonic processing. Minimize undesirable factors, as follows:

Foaming or Aerosoling

Always place the horn deep enough below the surface of the liquid to prevent violent motion or agitation on the surface. This problem is more critical when processing small volumes (for example, 0.3 to 5 ml). A conical-shaped tube or vial, such as a cut-down Eppendorf tube, is recommended. The shape of this type of container raises the liquid level without increasing the volume, thereby permitting the horn to be inserted more deeply below the liquid surface level. Foaming can be detected by a change in the sound level and a fluctuating reading on the power bar graph.

When aerosoling occurs, little or no energy couples reliably to the solution, and excessive top-layer heating results. Remedy this problem by placing the probe as deep as possible and setting the Amplitude control to 10% or 20% for a few seconds. Then gradually increase the Amplitude control to the level required.

Discoloration of the Processed Sample

If the tip touches the side of a glass tube or beaker, small glass particles are released, which gradually changes the sample to a greyish color. Excessive tip corrosion can also cause a greying or darkening condition.

Sterilizing and Preventing Cross-Contamination

You can sterilize horns and tips by removing them from the converter and autoclaving them. It is faster, easier, and equally effective, however, to sterilize horns by immersing them in a beaker of alcohol or other disinfectant and then turning the power on for a few seconds. This technique also removes unwanted residue from the horn and tip.

Disrupting Tissues and Solids

You can effectively homogenize or disrupt many kinds of tissue and other solids. Energy radiates only from the horn's tip. The energy is most concentrated within 1/2 inch (12.7 mm) of the face of the tip. When you treat tissue or solids in solution, the freely moving cells or particles pass the face of the tip many times during the process. When you treat a solid piece, however, the energy pattern from the tip of the horn has a tendency to repel the solid away from the tip. The solid does not receive treatment, but simply spins or circulates around the container.

You can effectively treat all but the most difficult materials by following these two steps:

1. Homogenize the tissues or solids by placing them in a high-speed blender with the solution.
2. Insert the horn in the liquid sample for complete disruption.

If you must disrupt solid pieces, especially those that are extremely resistant to breakage, without homogenizing them, place the horn directly over the tissue or right against it.

Using Glass Powders with Solution

To disrupt difficult cells and tissues, adding glass powders (5 microns to 0.5 mm) will materially decrease treatment times, especially when used in conjunction with the standard, high-intensity microtip. A ratio of 1 part glass powder to 2 parts liquid is recommended.

The Effects of Ultrasonic Irradiation on Various Biological Materials

Actinomyces: 3 minutes of sonifying produces excellent disruption with 50% protein release and excellent enzyme activity.

Actinomycin D: suspended in 3 minutes.

Aerobacter aerogenes: excellent breakage with better enzyme release than any other method. A low power setting can release sulfatase activity into the supernate with no obvious disruption of the majority of cells.

Aerobacter suboxydans: excellent breakage but requires higher power than *A. aerogenes*.

Algae secendesmus: 10 ml concentrated solution completely disrupts in 1 minute.

Alkaloids: total amount and speed of extraction are greater than with standard methods. Extraction from ipecac root in 30 seconds yielded more alkaloid than Soxhlet extraction in 5 hours.

Antibioticus: monocellular elements from surface-grown colonies obtained in 1 minute. Complete disruption in 5 minutes, 50% disruption in 2 minutes.

Antigen: the Sonifer Cell Disruptor is used extensively to produce antigens and vaccines. It can increase yield or expose otherwise unobtainable sites.

Aorta: 1 gram disintegrates in 2 minutes.

Aphanomyces: after blending, complete disruption in 3 minutes.

Arthobacter tumescens: 10 gm in 40 ml in 5 minutes for α coumaric reductase.

Ascaris eggs: 8 ml concentrated solution completely disrupts in 4 minutes.

Aspergillus: complete disruption in 4 minutes.

Aurefaciens: monocellular elements from surface-grown colonies obtained in 1 minute. Complete disruption in 5 minutes, 50% disruption in 2 minutes.

Azotobacter vinelandii: 15 ml buffered solution, 200 mg wet wt/ml completely disintegrates in 2 minutes.

B. anthracis: 80% disruption of anthracis in 4 minutes. Complete disruption of 10 ml of *erysipelothrix rhusipathiae* in 10 minutes.

B. cereus veg cells: disruption in a few seconds.

B. cereus spores: disruption of 10 mg/6 ml in 13 minutes.

B. megaterium spores: complete breakage of a concentrated 6 ml solution in 15 minutes.

B. sphaericus: major disruption in 1-3 minutes.

B. stereothermophilis spores: complete disruption in 2 minutes.

B. subtilis: disruption of 5 gm wet wt, 15 ml buffer, in 5 minutes.

B. subtilis veg cells: heavy suspension clears in 1 minute.

Bacillus stereothermophilus (thermophilic spore form): 98% disruption of 70 ml of 40% suspension in 15 minutes.

Bacillus brevis: 1:15 W/V in 3 minutes.

Bacteroides Symbiosis: 1-phosphorfructokinase (a soluble enzyme) has been isolated from this anaerobe by ultrasonic treatment. A 25 ml suspension was sonified for 10 minutes and centrifuged at 36,000 xg for 10 minutes.

Baker's yeast (saccharomyces cerevisiae): see Yeast.

Blastomyces dermatitidis: 95% disruption in 3 minutes.

Blood cells: red and white cells can be disrupted in a few seconds.

Boll weevil tissue: complete homogenization in a few seconds.

Bone: compact bone can be sonified and processed for microscopic sections in minutes. Other methods can require up to a week. Bone specimens treated in this way yielded large numbers of intact cells with little distortion. Malignant criteria are easily recognized. Tumor types studied were: osteosarcoma, chondrosarcoma, liposarcoma, chordoma, metastatic bronchogenic squamous and benign giant. Bone can be decalcified without injury to the cells, processed for microscopic sections, and diagnosed in a short time. Other methods require extensive treatment time.

Brain stem and adrenal gland: ultrasonic treatment dispersed 10 mg samples in 10 ml fluid, which is usually difficult without substantial loss of material. The suspension was analyzed for nucleotides.

Brain tissue: disintegrates instantly.

Brevi bacterium: 25 ml disrupts in 20 seconds.

Brevi bacterium acetylicum: approximately 3 minutes to disrupt large samples and measure TCA enzyme activity.

Brine shrimp: complete disintegration in 1 minute.

Brucella abortus: separates easily from leucocytes. At least 9 antigens extracted.

Bull sperm: contractile protein is easier to extract from tails after sonifying.

C. butyricum, C. cylindrosporum, C. kluyveri: vegetative cells easily disrupted.

C. pasteurianum: 3 minutes disruption for hydrogens reducing Ferredoxin with H₂.

Calcium: mouse Ehrlich ascites tumor cells were sonified for 1 minute to determine the amount of bound calcium present. Cells were labeled with calcium 45.

Candida albicans spores: 95% disruption of 1/2 gram dry wt. in a 15 ml solution in 35 minutes.

Carbon black: excellent small particle suspension.

Caryophanon latum: glucosamine, muramic acid, alanine, glutamic acid and lysine were obtained.

Catecholamine: can be extracted from heart muscle.

Cellomonas biazotea: disruption obtained with retention of malate dehydrogenase activity. Chicken spermatozoa: completely disrupts in 2 minutes.

Chlorella: completely disrupts in 3 minutes.

Chloroplasts: disrupt in a few seconds.

Cholesterol: apparent permanent suspension in 1 minute in water.

Desulfovibrio vulgaris: less than 30 seconds of ultrasonic treatment resulted in release of TCA enzymes.

Diplococcus: completely disrupts in 5 minutes.

DNA: breaks chains on low power instantly. Controlled degradation may be obtained.

Dyes: excellent rapid dispersion and homogenization.

E. coli.: 2 gm wet weight in 10 ml solution completely disrupts in 40 seconds. The Sonifer Cell Disruptor has been used extensively in research on this organism.

Egg whites: can be reduced to a homogeneous pipettable solution in 15 seconds on low power.

Ehrlich ascites: disrupts in a few seconds.

Electron microscopy: apertures are quickly cleaned.

Emulsions: 10 ml of most light mixtures become semi-permanent emulsions in about 1 minute without emulsifiers. Average particle size is usually well under 1 micron. Sterile emulsions can be prepared by ultrasonic treatment for feeding to germ-free animals.

Enterococcus: excellent disruption.

Erwina cartovara: complete disruption in 1-2 minutes depending on cell concentration.

Erythrocytes: disrupts in a few seconds.

Euglena gracilis: completely disrupts in a few seconds to isolate chloroplasts.

Eugoena: complete disruption in 12 minutes, 90% disruption in 8 minutes with pigment released.

Fat extraction: fat can be emulsified without injuring tissue with proper power selection. Lipid layer can be stripped from spores and mycobacteria.

Fibrin: complete suspension of 0.125 gm in 30 minutes.

Fish gill: complete disruption of 20 mg in 30 seconds.

Fish tissue: tissue homogenization for extractions and excellent particle size reduction in 8 minutes per 10 gm.

Fluorocarbons: extended treatment time will break down particle size to well under 1 micron and gives a fine homogenate.

Fossils: low power will clean debris from delicate fossils without injury. Micro fossils such as pollen can be separated from rocks to help identify the geological age of the strata. Removal of rock matrix.

Gamma globulin: the Sonifer Cell Disruptor was used to solubilize protein as one of the steps in the biosynthesis of gamma globulin from rabbit spleen.

Gangliosides: immunochemical and structure studies used ultrasonic treatment as one step.

Gastric mucosa: placing scrapings into a test tube and test tube into new water-filled cup horn caps permits these cells to be separated without breakage.

Graphite molybdenum disulfide: an excellent dispersion of this lubricant was made in a silicate binder.

Guanine: produces colloidal suspension in 1 minute.

Gymnodinium: solution completely disrupts in 6 minutes.

Haemophilus pertussis: preparation of successful immunological complexes.

Heart muscle: 1 gm disintegrates in 6 minutes.

HeLa cells: disruption to free virus in a few seconds without injury.

Hemophilus pertussis: an immunological compound prepared.

Herpes virus: may be quickly released without injury.

Histoplasma capsulatum: ultrasonic treatment for 7 minutes completely ruptures cells prepared by formalin fixation. Good enzyme activity is obtained.

Human serum proteins: ultrasonic treatment causes a reproducible change in the electrophoretic behavior of normal human serum consisting of an increase in material migrating in the x and b globulin zones with a reduction in the albumin and y globulin fractions.

Hydrocortisone: smaller crystals were produced by ultrasonic treatment.

Hydrophilic vegetable gums: disperses and solubilizes hydrophilic vegetable gums in water; makes dispersions of added particulate matter.

Intracellular membrane: disruption and particle size reduction obtained in 30-60 seconds.

Isoenzymes: selectively activated with respect to time and intensity of treatment.

Kidney: 1 gm disintegrates in 3 minutes.

Kidney stones: easily broken in seconds in vitro.

Klebsiella: excellent disruption.

L. arabinosis: complete disruption to free virus in 2 minutes without injury.

Lactobacillus: 0.5 gm in 15 ml completely disrupts in 11 minutes. Excellent release of acetokinase.

Lenconostoc mesenteroides: ultrasonic treatment for 15 minutes using high power for disruption.

Leukocyte lysozyme activity in myelocytic leukemia: the cell suspension was ultrasonically treated and samples assayed for lysozyme activity. The lysozyme concentration of the leukocytes $\mu\text{g}/10^6$ cells was determined.

Linoleic acid: made suspension in water in 30 seconds.

Liver tissue: 1 gm homogenizes in less than 1 minute.

Lung tissue: 1 gm homogenizes in 2 minutes.

Lymphacytis: complete disruption in 15 seconds.

Lymphocyte nuclei: complete disruption in 6 minutes.

Lymph gland: direct injection lymphography with a modified radiopaque emulsion was obtained by ultrasonic treatment in a functional procedure producing lymphatic structure detail.

Lysosomes: released enzymes quickly.

Malaria prolozoa: fast, excellent disruption.

Maple bark spores: complete disruption in 14 minutes.

Measles: disruption of virus antigen clumps present in infected cells on low power. Ultrasonic treatment increased antigen titer 4-8 fold.

Methanobacillus omelianskii: 1 gm cells wet wt/ml completely disintegrates in 2 minutes for assaying methane.

Microbacterium lacticum: ultrasonic treatment used for malate dehydrogenase extraction.

Micrococci: a 13 ml solution completely disrupts in 15 minutes.

Micrococcus lactiliticus: 75 ml of a 20% suspension was disintegrated in 15 minutes and a good yield of the enzyme Xanthine dehydrogenase extracted.

Mineral rock: excellent for cleaning surfaces between polishing stages.

Mitochondria: separate from cells without injury. Mitochondria themselves can be broken with longer ultrasonic treatment. Inner membrane subunits also isolated.

Muscle tissue: 1 gm homogenized in 4 minutes; heart muscle in 6 minutes.

Mycobacteria: a 20 ml growing media completely disrupts in 14 minutes. Clumps break quickly. An immunological compound prepared.

Mycoplasma antibody: a suspension of Campo-W cells treated for 5 minutes gave 12 lines with the sera in a gel diffusion test. The extract was estimated to contain 12.75 mg protein per ml by Blaret reaction.

Myeloma tumor cells: complete disruption in 10 minutes, 30% disruption in 2 minutes.

Myleran: made colloidal suspension and dissolved in approximately 1 minute.

N. crassa: nuclease was isolated and purified from conidial extracts after 5 minutes treatment.

Naegleri gruberi: this free-living soil amoeba was treated ultrasonically to release subcellular infectious material.

Neurospora: 40 ml, 4 minutes, produced more protein than freeze thawing for study of enzymatic synthesis of cystathionine.

Nocardia ostenodes: breaks clumps and disintegrates in less than 10 minutes.

Nucleoprotein: extracted from tissue. May be degraded selectively.

Oil and water emulsions: permanent, stable emulsions in a few seconds. Particle size reduced to less than micron (each case slightly different). Oil in water/water in oil phases can be obtained in same vessel.

Oyster shell: small, clean hole can be drilled with micro tip in 3 minutes. No cracking is produced.

Paracolon: excellent disruption.

Parasites: separated from red blood cells in a few seconds.

Pasteurella pestis: complete disruption in 30 minutes using high power.

Penicillium: complete disruption in 3 minutes.

Pesticides: ultrasonic treatment resulted in a 16-fold improvement in the potency of the antigen used with Microcrystalline Cellulose as a thin-layer absorbent for chromatographic separation.

Phosphatidate phosphohydrolase: the most potent inhibitors for this enzyme were obtained by making five dispersions with the Sonifier Cell Disruptor.

Phospholipid micelles: produced stable preparations for an indefinite period.

Plant cells: 30% packed plant cells (W/V) and distilled water (depending on type) can be completely disrupted in 1-15 minutes.

Plant tissue: 1 gm dried tissue suspended in alcohol disintegrates in about 5 minutes.

Platelets: complete disruption according to size from 20 seconds to 4 minutes.

Pneumococci: preserved in formalin for several years; completely disrupts in 6 minutes.

Polio virus: excellent disruption of this most difficult virus.

Powders: broken down to a small, relatively uniform particle size.

PPLO: complete disruption in 2 minutes.

Propionobacteria: releases sulphhydro groups intact; 70 ml of 20% suspension processed for 10 minutes.

Propionibacterium shermanii: 2 minutes for extraction of citrate synthase.

Proteus: excellent disruption.

Pseudomonas aeruginosa: rapid, complete disintegration.

Pseudomonas fluorescens: 2 gm wet wt in 10 ml completely disrupts in 1 minute.

Pulmonary cytodagnosis: the mucous in sputum can be evenly dispersed, giving a quick representative sample of cells for cytologic examination. Cells are liberated from the mucous of sputum that had been immersed in 50% alcohol or a fixative.

Ragweed pollen: 15 ml dispersion completely disintegrates in 11 minutes.

Rat bone: 1/2 gm disintegrates in 4 minutes.

Rat liver: complete disruption in 3 minutes.

Rat liver mitochondria: ultrasonic treatment has been used extensively for the varied research performed on this material. Disruption occurs in seconds.

Rat skin: 1 gm completely disintegrates in 4 minutes.

Red and white blood cells: ultrasonic treatment breaks particle size to 100 Angstroms. Complete disruption in 1 minute. 25 gms/100 ml, saline or plasma, sample treated 15 seconds, 35% disruption. Adenosine triphosphate was shown to be membrane-bound by this method.

Reovirus: dissociates cell-bound and aggregated virus. Maximum titer with 4 ml of virus was achieved in 2 minutes.

Retinal outer segments: ultrasonic treatment breaks particles down to almost molecular size.

Rhodopseudomonis palustris: complete disruption in 4 minutes.

Rhodospirillum rubrum: excellent disruption in a few seconds.

Rimosus: monocellular elements from surface-grown colonies obtained in 1 minute. Complete disruption in 5 minutes, 50% disruption in 2 minutes.

RNA: rapid and thorough re-suspension of 9 TCA pellets during extractions.

Rocks: excellent for disaggregation of sedimentary rock and for cleaning material rock surfaces between polishing stages.

S. faecalis: excellent disruption in 1 minute.

S. fragilis: 5 minutes yielded excellent release of galactokinase, more than any other method. Subcellular particles may be extracted or disrupted.

Saliva glands: complete disruption.

Salmonella: various culture media or phosphate buffered saline disintegrated between 40 and 50% in 10-20 minutes. Sonifying was one step in an improved assay for enzyme thiogalactoside transacetylase.

Salmonella typhimurium and enteritidis: bacteria were suspended in 1/300 volume of original culture, sonified for 4 minutes and centrifuged for 20 minutes at 20,000 g. Extracts were found to catalyze the synthesis of cytidine diphosphate 3, 6-dideoxyhexoses.

Scholasticism mansion: complete disruption.

Sedimentary rock: completely disperses flocs with the release of all bound silt and clay particles.

Sediments: ultrasonic treatment disperses fine material permitting quick, neat separation of sand from silt and clay fractions.

Serial number restoration: used in crime laboratories to restore obliterated serial numbers.

Serratia marcescens: complete breakdown of a concentrated solution in 1 minute.

Serum: quickly homogenized.

Serum cholinesterase: activated by ultrasonic treatment. Different cholinesterase isoenzymes may be activated and inactivated selectively.

Shale: excellent disaggregation of all fine-grained sedimentary rocks.

Shellfish: by drilling a clean hole with the micro tip, various fluids or samples may be withdrawn or injected from living shellfish without destroying the animals.

Shigella: quick disruption.

Skin: 1 gm disintegrates in about 4 minutes. Epidermal homogenates that respire and utilize substrate can be extracted.

Soil: separates solid particles without use of oxidants, acids or peptizing agents and yields stable suspensions.

Sperm (human): tails are broken instantly. Heads are broken in 20 minutes.

Sputum: cancer cells are more easily detected after ultrasonic treatment due to even dispersion of cells and sputum, and complete liberation of the cells from sputum.

Staphylococcus: a concentrated solution disrupts 98% in 10 minutes. With 1 gm cells wet wt, to 2 gm water, 54.5 mg/ml of protein was released.

Starch: obtained by extracting from green plant leaf homogenate.

Streptococcus, Group A: a 20% suspension in a 15 ml solution completely disrupts in 15 minutes.

Streptomyces: monocellular elements from surface-grown colonies obtained in 1 minute. Complete disruption in 5 minutes, 50% disruption in 2 minutes.

Subcellular particles: may be separated or broken depending on power selection and length of time.

Sulfanilamide: excellent dispersion in less than 1 minute. Continued ultrasonic treatment will produce complete disruption.

Sulfapyridine: excellent dispersion in less than 1 minute. Continued ultrasonic treatment will produce complete disruption.

Synovial fluid: ultrasonic treatment is an excellent means of reducing fluid viscosity. It is simpler and faster than using hyaluronidase.

T. pyriformis: excellent disruption, 8 enzymes released.

Tablets: complete disruption in 2-40 seconds, depending on type.

Tea: excellent extraction.

Tetrahymena: disrupts in a few seconds. Enzymes which have been monitored include: succinate, lactate, B-hydroxy butyrate, glutamate and DPNH oxidases, DPNH-cytochromeC, reductase and ribonuclease. Activity of DPNH oxidase was twice that of the best previous experiments.

Thermoactinomyces: disruption of hyphae. Homogenization of protein complex without denaturation.

Thermophile negative: good disruption within 2 minutes.

Thermophilic bacillus: isocitrate lyase was extracted from a spore-forming bacillus similar to *Stearothermophilus*. A washed cell paste suspended in a phosphate buffer was sonified 1-2 minutes and the supernatant was used for enzyme experiments without further treatment. Extracts could be frozen and stored without loss of activity.

Thiouric acid: dissolved in a few seconds.

Thymus cells: complete disruption in 15 seconds.

Tissue culture cells: complete disruption in a few seconds. To avoid damage to free organelles and to obtain intact lysosomes, use low power at short exposure.

Toxin and antitoxin: one example of many: Toxin preparations of whole cell lysate (WCL) of the Inaba serotype strain 569E of the classic biotype of cholera vibrio were grown on 3% Bacto peptane agar and harvested in distilled water at 18 hours. The unwashed suspensions were solubilized ultrasonically, clarified by centrifugation and the supernate freeze-dried for the titration of cholera toxin in the rabbit ileal loop.

Toxoplasma gondii: can be separated from white blood cells without injury.

Transplantation antigens: were extracted from spleen, thymus and lymph nodes.

Trichomonas foetus: complete disruption in a few seconds.

Triolein: complete stable emulsion in 2 minutes.

Trypanosomes: concentrated 10 ml solution completely disrupts in 4 minutes.

Uterus muscle: a 1/5 gm, 3 cc solution completely disrupts in 3 minutes for coenzyme Q determination.

Vaccines: numerous advantages, such as more antigenic material released than usual, and the production of vaccines not obtainable by classified methods.

Various bacilli: complete disruption in 3 minutes.

Vibrio comma: excellent disruption.

Vibrio extraction: excellent for experimental vaccines. Evidence of breakage of virus/antibody bonds. Virus can be extracted without damage at low power, or broken at high power.

Vitamin E: 30 seconds of ultrasonic treatment put material in solution with a resultant permanent suspension.

W138 virus: cell-free V-2 virus obtained in 30 seconds using 6 ml of Veronal buffer with W138 cells containing V-2 virus.

Yeast: complete disruption in 3-10 minutes. Complete disruption of 9 grams pressed yeast in 18 ml buffer in 8 minutes. Protein release, 52 mg/ml from an aged sample.

APPENDIX B: Parts Lists

Replacement Parts

Item	Description	EDP Number
Replacement Fuses	3.15 Amp (for Model 250, 117V or 200-245V)	200-049-128
	5.00 Amp (for Model 450, 117V)	200-049-121
	2.00 Amp (for Model 450, 200-245V)	200-049-120
Cordsets	North American (117VAC, 5-15R)	200-030-012
	Harmonized European (200-245)	000-087-062
Silicon Grease	Stopcock Grease (silicone)	101-053-002
Stud	Replacement adaptor Stud (horn to converter)	100-098-249
Converter	102C Converter (CE compliant)	101-135-022
Wrenches	For use with Branson Sonifier Cell Disruptors. • Spanner	201-118-019
	• Open-end, for 1/2" disruptor tip	201-118-010
1/2 Wave Horn Extension	Extends 1/2" diameter disruptor horn an additional 1/2 wavelength (approx. 5") at a 1/2" diameter.	101-147-049

Optional Items

Item	Description	EDP Number
15-pin User I/O cable	15-conductor cable, 15 ft., DB15M to DB15M, for User I/O port	101-240-014
RS-232 cable	Serial cable, 25 ft., DB9M to DB25F, for remote terminal or computer use	101-241-249
Temperature Probe	Omega Technologies Model #OL-703-PP, 1/4" plug connector	200-060-022
WYSE Terminal (requires RS-232 cable)	Wyse WY-55 Terminal with enhanced PC-style keyboard, 120-230V 50/60 Hz	200-103-228
Okidata 520 printer	Okidata Microline 520 printer, dot matrix, 9-pin, parallel interface, 120V 50/60 Hz (North America)	200-143-125
Printer cable	Parallel printer cable, 15 ft., DB25M to Centronics-type	100-143-043

Digital Sonifier System Kits

The following system Kits may be ordered. Each Kit contains the Digital Sonifier system for the voltage indicated, 102C converter, cordset, and horn as noted.

Item	Kit Description	EDP Number
Kit, Digital Sonifier Model 250, 117V 1/2" Horn	Digital Sonifier 250 system kit, 117 volt, including 1/2" horn	101-063-588
Kit, Digital Sonifier Model 250, 200-245V 1/2" Horn	Digital Sonifier 250 system kit, 200-245 volt, including 1/2" horn	101-063-589
Kit, Digital Sonifier Model 450, 117V 1/2" Horn	Digital Sonifier 450 system kit, 117 volt, including 1/2" horn	101-063-592
Kit, Digital Sonifier Model 450, 200-245V 1/2" Horn	Digital Sonifier 450 system kit, 200-245 volt, including 1/2" horn	101-063-591
Kit, Digital Sonifier Model 450, 117V 3/4" Horn	Digital Sonifier 450 system kit, 117 volt, including 3/4" horn	101-063-590
Kit, Digital Sonifier Model 450, 200-245V 3/4" Horn	Digital Sonifier 450 system kit, 200-245 volt, including 3/4" horn	101-063-593

APPENDIX C: Accessories Parts List

Item	Description	Branson EDP Number
Disruptor Horns	• 1/2" diameter stepped, w/grad. scale	101-147-036
	• 1/2" diameter stepped, tapped	101-147-037
	• 1/2" diameter stepped, solid	101-147-038
	• 3/8" diameter stepped, solid	101-147-039
	• 1/2" diameter exponential, tapped	101-147-040
	• 1/2" diameter exponential, solid	101-147-041
	• 1/2" diameter catenoidal, solid	101-147-042
	• 3/4" diameter stepped, solid	101-147-043
	• 1" diameter stepped, solid	101-147-044
	• 3/4" diameter solid, high gain	101-147-035
Cup Horns	Permits material to be treated while isolated in small test tubes. Cups have transparent plastic bodies. Horn is attached to converter and mounted upside down. • 2" diameter	101-147-047
	• 3" diameter	101-147-048
Continuous Flow Attachment	Permits continuous processing of low-viscosity materials with rates up to 38 liters/hour. Designed primarily for emulsifying, dispersing, and homogenizing, this attachment will disrupt most cells, with the exception of the more difficult types. Materials being treated may be passed through the attachment more than once to obtain the desired results. A water jacket and input, output, and overflow connections are provided. For use with horns having outside threads.	100-146-171

Item	Description	Branson EDP Number
Continuous Flow, Glass Rosett Cooling Cell	Cooling cell for continuous circulation of the substance being processed. The cell is equipped with intake and output connections for continuous processing and a double chamber for cooling. Normally, adequate cooling is achieved by connection to the cold water tap, or by using a closed-circuit system. An ice/salt water solution will maintain a temperature below 0°C. Borosilicate glass construction allows observation during treatment. Not suited for difficult cells.	201-123-004
Sealed Atmosphere Treatment Chambers	Used for batch treatment of infectious materials. Input and output connections allow filling and emptying without breaking the air-tight seal and permit processing with an inert gas. Stainless steel. • 3-10 ml	101-021-001
	• 6-15 ml	101-021-002
	• 25-50 ml	101-021-003
	Same as above 101-021-001 series, but with cooling water jacket. • 3-10 ml	101-021-004
	• 6-15 ml	101-021-005
	• 25-50 ml	101-021-006
Flat Tip	Replacement for 1/2" horn, 1/4"-20 thread	101-148-013
Tapered Microtips	For processing small volumes. Attaches to standard tapped disruptor horn. Tip amplitude is 3-1/2 times greater than that of standard horn. Recommended for difficult applications, such as spores, fungi, yeast, muscle and connective tissue. Excellent results on volumes ranging from 3 to 20ml in a comparatively short time. • 1/8" diameter	101-148-062
	• 3/16" diameter	101-148-069
	• 1/4" diameter	101-148-070

Item	Description	Branson EDP Number
Double-step Micro Tip Assembly	A two-piece horn consisting of a coupling section and a lower tip. The standard disruptor horn must be removed prior to using this tip. Recommended for use on extremely small volumes (0.5-20 ml). Applications include red and white blood cells, tissue culture cells, Hela cells. Overall length is 9-1/8" with 1/8" diameter in the lower 2-1/8". NOTE: The double-step microtip is to be used only with coupler.	109-067-683
Double-step Micro Tips	• Coupler section only	101-147-050
	• Micro Tip section only	101-148-063
Rosett Cooling Cells	Borosilicate glass cell has conical shape with three arms to allow circulation of substance being processed. When the cell is immersed in a cooling bath, the enlarged glass surface areas, plus circulation through the arms, provide an effective means of heat exchange. • Model 25, 8-25 ml	201-123-001
	• Model 50, 25-180 ml	201-123-002
	• Model 250, 35-300 ml	201-123-003
Tissue Disruptor	Designed for disintegration of difficult tissues. Stainless steel construction. Cell bottom holds 6g of tissue. A water jacket is provided for cooling.	101-021-007
Soundproof Enclosure	Reduces mechanical noise generated during liquid processing to a normal level. Especially useful when using a cell disruptor for extended periods.	101-063-275
Glass Beads	For cell homogenization. Waterproof, 1 pound packages • 1/2 mm diameter	201-002-004
	• 25 micron diameter	201-002-003
	• 35 micron diameter	201-002-005

For Your Notes

APPENDIX D: Wyse-55 Settings

Wyse-55 Terminal Setup Parameters

The following setup is for the Wyse model WY -55 Terminal with the extended PC-style keyboard, available as a kit from Branson using EDP# 200-103-228.

All Wyse terminal Set-Up is done directly from the Wyse terminal's PC-style keyboard, once it is set up and plugged in. Refer to the Wyse terminal box for manufacturer's instructions.

Programming the Wyse-55 Terminal

Before the Wyse-55 can be used with the Digital Sonifier, the communications protocol information of the Wyse-55 terminal must be set to match it. Information on how to program the Wyse terminal is included in the instruction sheet packed with each terminal.

The following parameters are displayed on the Wyse terminal during its setup. The options listed in the following tables are important for correct operation. A very few are critical, and they are highlighted below. Other parameters within the Wyse terminal should not be changed from the values listed.

The printing capability of the Wyse terminal is not supported at this time.

Wyse-55 Terminal Parameters

Set the function-key parameters on the Wyse-55 terminal for correct operation with the Digital Sonifier. Parameters that are highlighted in the following lists are important to its functioning with the Digital Sonifier.

Step	Operation
1	Connect the Wyse-55 terminal and turn it on.
2	Press the SHIFT and SELECT keys together. The terminal is placed in its Setup mode.
3	Press a function key (F1 thru F8) to change the Wyse set-up.
4	When done, press the F12 key to access the Save screen. Press the Spacebar to toggle the Save options (All, Yes, No) until you have 'Yes' showing (if you wish to save your changes), or 'No' if you wish to ignore your recent changes.
5	Press F12 again to exit the Wyse Setup mode.

Wyse-55 Function Key Setup Parameters

F1: F1 Key Setup, DISP

Columns	80	Cursor	Blink Blk	Scrn Saver	Off
Lines	25	Display	Reverse	Char Cell	10x15
Page	1 x Lines	Autopage	Off	80/132 Clr	Off

F2: F2 Key Setup, GENRL

Personality	220-8	Enhance	On	Status Line	Off
Scrl	Jump	Autoscrl	On	Wrap EOL	Off
Rcv CR	CR	Monitor	Off	Recognize DEL	Off

F3: F4 Key Setup, KEYBD

Keyclick	On	Repeat	On	Keycode	ASCII
Keylock	Caps	Language	US	Corner Key	Funct

F4: F4 Key Setup, COMM

Comm	FDX	Xmt Lim	None	Answerback Mode	Off
Mdm Rc Hsk	None	Mdm Rc Hsk Level	192	Mdm Xmt Hsk	None
Aux Rc Hsk	None	Send ACK	On	Aux Xmt Hsk	None

F5: F5 Key Setup, PORTS

Mdm Baud Rate	9600	Mdm Data/Parity	8/None	Mdm Stop Bits	1
Aux Baud Rate	9600	Aux Data/Parity	8/None	Aux Stop Bits	1
Host Port	Modem Port	Printer Attached	On	Nulls Suppress	On

F6: F6 Key Setup, MISC

WPRT Intensity	Normal	WPRT Rev	Off	WPRT UndrIn	Off
Blk End	CRLF/ETX	Attribute	Char	Multiple Page	Off
Margin Bell	Off	Bell Volume	1	Rest/Act. Times	None

F7: F7 Key Setup, ANSI1

Char Set	Multinational	Char Mode	Multinational	ANSI ID	VT100
Cursor Keys	Normal	Keypad	Numeric	DEL	DEL/CAN
Feature Lock	Off	Fkey Lock	Off	Newline	Off

F8: F8 Key Setup, ANSI2

Print	ASCII	Print Area	Page	Print Term	None
Send	All	Send Area	Page	Send Term	None
Xfer Term	EOS	Auto Answerback	Off	Keys	Typewriter

Do not make changes to the F9, F10, or F11 keys. Doing so can affect the operation of the Wyse terminal with the Digital Sonifier. Use the default settings.

For Your Notes

Index

A

accessories	4-3
accessories parts list	C-1
aerosoling	A-3
amplitude	
parameter entry	6-29
assembling the equipment	4-6

B

back panel connections	2-6
baud rate	
setup.....	6-17
biological materials	
effects of ultrasonic irradiation on.....	A-4
block diagram	4-2
Branson	
how to contact	1-6

C

- caution, warning, and error messages 6-41
- compliance with RFI guidelines 1-3
- component description 4-2
- components
 - standard 4-2
- connecting the tip to the horn 4-8
- connecting tips, horns, and converters 4-7
- connection
 - printer 4-11
 - remote terminal 4-10
- connections
 - back panel 2-6
- continuous-flow attachment 4-5
- controls 2-2
 - front panel 6-3
- converters
 - connecting 4-7
- cross-contamination
 - preventing A-3
- cup horn 4-4

D

- date
 - setup 6-15
- description
 - physical 5-3
- Digital Sonifier
 - introduction 2-1
 - keypad description 2-3
 - overview 2-1
 - technical specifications 5-1
- discoloration
 - of sample A-3
- displays during the experiment 6-40
- disrupting tissues and solids A-3

E

effects of ultrasonic irradiation on biological materials ..	A-4
electrical connections to equipment	4-10
entering operation parameters	6-23
entering parameters from the keypad	6-23
entering system setup parameters	6-3
equipment	
assembling	4-6
error	6-41
experiment	
displays during	6-40

F

features	2-7
flow-thru horn	4-4
flow-thru Rosett cell	4-5
foaming	A-3
front panel controls	6-3

G

glass powder	A-4
glossary	2-7
guards and safety equipment	4-11

H

horn	
connecting tip to	4-8
horns	
connecting	4-7
how to contact Branson	1-6

I

input power requirements	4-10
installation and setup	4-1
installation checklist	4-1
intended use	1-1
introduction	2-1

K

- keypad
 - entering parameters from 6-23
 - keypad description 2-3

L

- language
 - setup 6-9
- limitation of remedy and liability 1-6
- limited warranty 1-4
- limiting temperature rise A-1

M

- maintenance 7-1
- maximum temperature
 - parameter entry 6-27
- messages 6-41
- micro tip 4-3
- minimizing undesirable factors A-2
- model
 - setup 6-21
- modes 6-1

O

- operating considerations A-1
- operation 6-1
- operation parameters
 - entering 6-23
- optional items 4-3
- optional items parts list B-1
- overview 2-1

P

parameter entry	
amplitude	6-29
maximum temperature	6-27
pulse off	6-33
pulse on	6-31
pulse temperature	6-35
time	6-25
parameters	
entering from keypad	6-23
pause	6-37
performance specifications	5-2
physical description	5-3
power output loss	7-2
power requirements	
input	4-10
precautions	1-1
presets	
save and recall	6-36
preventing cross-contamination	A-3
printer	
setup	6-5
printer connection	4-11
printing and sending reports	6-39
pulse off	
parameter entry	6-33
pulse on	
parameter entry	6-31
pulse temperature	
parameter entry	6-35

R

- recall preset..... 6-36
- remedy and liability
 - limitation of 1-6
- remote
 - setup..... 6-7
- remote terminal 6-37
- remote terminal commands 2-6
- remote terminal connection 4-10
- reports
 - printing and sending 6-39
 - setup..... 6-19
- requirement specifications..... 5-1
- returns 1-3
- RFI guidelines
 - compliance with 1-3
- risk of loss 1-3
- Rosett cell..... 4-5

S

safety	1-1
safety considerations.....	1-1
safety equipment	4-11
safety measures	1-2
sample	
discoloration	A-3
save and recall presets	6-36
save preset.....	6-36
sending reports.....	6-39
setting up the workplace.....	1-2
setup.....	4-1
setup procedure	4-6
shipment.....	1-3
solids	
disrupting.....	A-3
solution	
using glass powders with	A-4
soundproof box.....	4-5
specifications	
performance	5-2
requirement	5-1
standard components.....	4-2
start and stop control.....	4-10
states	6-2
sterilizing	A-3
support	1-1
system	
intended use of.....	1-1
system block diagram.....	4-2
system component description	4-2
system modes	6-1
system setup	
baud rate	6-17
date	6-15
language.....	6-9
model.....	6-21
printer	6-5
remote	6-7
reports	6-19
temperature	6-11
time of day.....	6-13
system setup parameters	6-3
system states	6-2

T

technical specifications for the Digital Sonifier 5-1

temperature

 setup..... 6-11

temperature probe..... 4-11

temperature rise

 and vessel capacity A-2

 limiting A-1

terminal..... 6-37

terms and conditions of sale..... 1-3

test..... 4-11

time

 parameter entry 6-25

time of day

 setup..... 6-13

tip erosion 7-1

tips

 connecting 4-7

tissue disruptor 4-5

tissues

 disrupting A-3

troubleshooting 7-1

U

ultrasonic irradiation

 effects on biological materials A-4

ultrasonic test 4-11

undesirable factors

 minimizing A-2

user I/O..... 4-10

using glass powders with solution A-4

V

vessel capacity

 and speed of temperature rise A-2

W

warning..... 6-41
warranty..... 1-4
warranty statement..... 1-3
workplace
 setting up..... 1-2

