



REACH-IN DRY CO₂ INCUBATOR

MODEL: 1917 & 1927

INSTALLATION AND OPERATION MANUAL

Sheldon Manufacturing Inc. P.O. Box 627 Cornelius, Oregon 97113
EMAIL: tech@Shellab.com INTERNET: <http://www.Shellab.com/~Shellab>
1-800-322-4897 (503) 640-3000 FAX (503) 640-1366

TABLE OF CONTENTS

SECTION 1.0	RECEIVING AND INSPECTION
SECTION 2.0	GRAPHIC SYMBOLS
SECTION 3.0	INSTALLATION
SECTION 4.0	CONTROL PANEL OVERVIEW
SECTION 5.0	OPERATION
SECTION 6.0	FYRITE READING
SECTION 7.0	MAINTENANCE
SECTION 8.0	TROUBLESHOOTING
SECTION 9.0	PARTS LIST
	UNIT SPECIFICATION
	SCHEMATICS

REV 6/04
4861495

This unit is a CO₂ incubator for professional, industrial or educational use where the preparation or testing of materials is done at approximately atmospheric pressure and no flammable, volatile or combustible materials are being heated. These units are not intended for hazardous or household locations or use.

RECEIVING AND INSPECTION





IMPORTANT: READ THIS INSTRUCTION MANUAL IMMEDIATELY.

Your satisfaction and safety require a complete understanding of this unit, including its proper function and operational characteristics. Be sure operators are given adequate training before attempting to put the unit in service. NOTE: This equipment must be used for its intended application; any alterations or modifications will void your warranty.

- 1.1 Inspection:** The carrier, when accepting shipment, also accepts responsibility for safe delivery and is liable for loss or damage claims. On delivery, inspect for visible exterior damage, note and describe on the freight bill any damage found and enter your claim on the form supplied by the carrier.
- 1.2** Inspect for concealed loss or damage on the unit itself, both interior and exterior. If any the carrier will arrange for official inspection to substantiate your claim. Save the shipping crate until you are sure the unit has been delivered in good condition.
- 1.3 Return Shipment:** If for any reason you must return the unit, contact your customer service representative for return authorization and supply data plate information. Please see the manual cover for information on where to reach customer service.
- 1.4** Make sure that all of the equipment indicated on the packing slip is included with the unit. Carefully check all packaging before discarding. This unit is equipped with 6 shelves, 24 shelf clips, CO₂ tubing kit and 4 adjustable feet.

GRAPHIC SYMBOLS

Your incubator has been provided with a display of graphic symbols on the control panel which is designed to help in identifying the use and function of the available user adjustable components.

- 2.1  Indicates that you should consult your manual for further description or discussion of a control or user item.
- 2.2  Indicates "Temperature"
- 2.3  Indicates "Over-Temperature Safety".
- 2.4 **C°** Indicates "Degrees Centigrade".
- 2.5 **CO₂** Indicates "Carbon Dioxide".
- 2.6  Indicates "Gas" (CO₂ for this unit.)
- 2.7  Indicates "AC Power On".

INSTALLATION

Local city, county or other ordinances may govern the use of this equipment. If you have any questions about local requirements, please contact the appropriate local agency. Installation may be performed by the end user. It is unnecessary for this unit to be installed by a technician.

Under normal circumstances this unit is intended for use indoors, at room temperatures between 5° and 40°C, at no greater than 80% Relative Humidity (at 25°C) and with a supply voltage that does not vary by more than 10%. Customer service should be contacted for operating conditions outside of these limits.

- 3.1 Power Source:** The power supply must be properly grounded (earthed) and correctly sized to match the unit data plate rating. **VOLTAGE SHOULD NOT VARY MORE THAN 10% FROM THE DATA PLATE RATING.** These units are intended for a 50/60 Hz application. If supplied with a detachable cord set, plug the female end into the inlet on the unit and the male plug into the supply. Assure that units requiring a fuse have a fuse installed. This fuse may be at the inlet or part of the cord set male plug. Note that electrical supply to the unit must conform to all national and local electrical codes.
- 3.2 Location:** When selecting a site for the unit, consider conditions which may affect performance, such as heat from steam radiators, ovens, autoclaves, etc. Avoid direct sun, fast-moving air currents, heating/cooling ducts, and high-traffic areas. To ensure air circulation around the unit, allow a minimum of 5cm of clearance between the incubator and surrounding walls, or partitions which might obstruct free air flow.
- 3.3 Lifting/Handling:** These units are heavy and care should be taken to use appropriate lifting devices that are sufficiently rated for these loads. Units should only be lifted from their bottom surfaces. Doors, handles and knobs are not adequate for lifting or stabilization. The unit should be completely restrained from tipping during lifting or transport. All moving parts, such as shelves and trays should be removed and doors need to be positively locked in the closed position during transfer to prevent shifting and damage.
- 3.4 Leveling:** The unit must sit level and solidly. Leveling feet are supplied and should be installed in the four holes in the bottom corners of the unit. With the feet installed and the unit standing upright, each foot can be raised by turning it in a counterclockwise direction. An opposite clockwise rotation will lower that foot. Adjust the foot at each corner until the unit stands level and solid without rocking.

3.5 Cleaning: The unit chamber should be cleaned and sterilized prior to operating. Use a suitable disinfectant that is appropriate to your application. **DO NOT USE** chlorine-based bleaches or abrasives as this will damage the interior chamber. **DO NOT USE** spray cleaners that might leak through openings and cracks and get on electrical parts or that may contain solvents that will harm the coatings. Special care should be taken when cleaning around sensors to prevent damage.

Warning: Never clean the unit with alcohol or flammable cleaners with the unit connected to the electrical supply. Always disconnect the unit from the electrical service when cleaning and assure all volatile or flammable cleaners are evaporated and dry before reattaching the unit to the power supply.

3.6 Shelves and Interior Parts: Shelving and clips are supplied with the unit. **See Figure 1.**

Figure 1

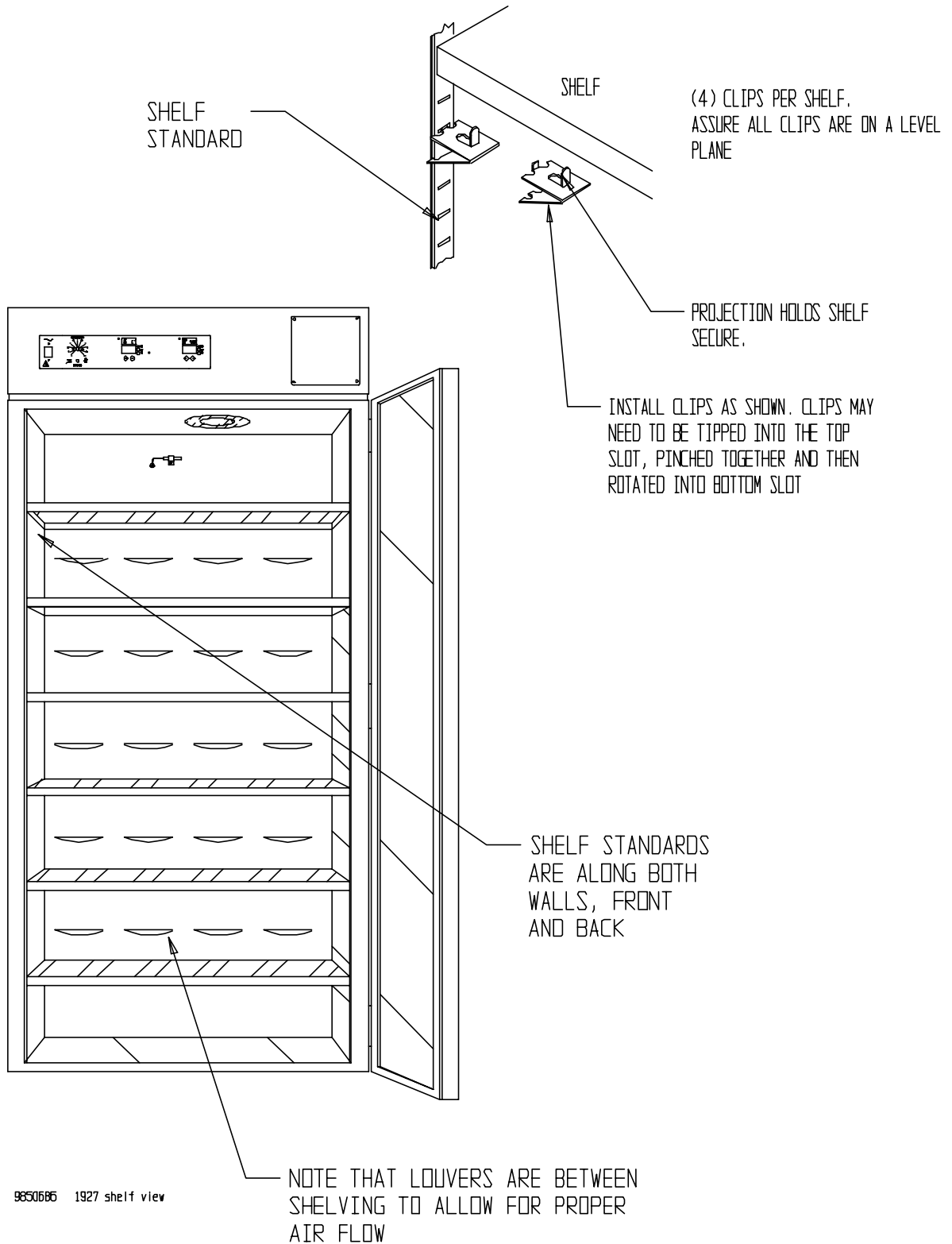

CONTROL PANEL OVERVIEW (See Figure 2)

- 4.1 Power Switch:** The main power I/O (On/Off) switch on the panel controls all the power to the incubator. It must be in the I/On position before any systems are operational.
- 4.2 Main Temperature Controller:** Marked C°, this controller contains the digital temperature display, UP and DOWN arrow pads, HIGH and LOW alarm indicators and an alarm MUTE indicator.
- A. Digital Temperature Display** indicates the actual temperature within the chamber to .1°C.
 - B. UP and DOWN Arrow Pads** are used for inputting the set point, calibrating the display and muting or unmuting the audible alarm.
 - C. HIGH and LOW Alarm Indicators** will light whenever there is an alarm condition associated with the temperature within the incubator.
 - D. Alarm MUTE Indicator** will light whenever the audible alarm has been muted.
- 4.3 Heating:** This pilot lamp is on whenever the temperature controller is energizing the heating element. The element will go on and off as heat is needed to maintain the set point temperature.
- 4.4 High Limit Thermostat:** Marked SET HIGH LIMIT, the High Limit Thermostat is completely independent of the Main Temperature Controller and functions as an override control. If at any time the Main Temperature Control fails in the ON position, the chamber temperature is then limited to the High Limit Thermostat set point which is manually set approximately 1°C above the Main Controllers set point. Note that the HEATING indicator will continue to function under the control of the High Limit Thermostat. It is not recommended that the unit be allowed to operate for an extended period of time using the High Limit to control temperature as temperature uniformity will suffer.
- 4.5 Safety Activated:** This pilot lamp is on whenever the High Limit Thermostat has taken control of the incubator and shut down the elements. Under normal operating conditions this pilot lamp should never be on.

- 4.6 CO₂ Sample Port:** Chamber atmosphere can be taken from the Sample Port at the upper front corner on the left side of the chamber. CO₂ concentration can then be checked using a FYRITE gas analyzer or other instrument such as a gas chromatograph.
- 4.7 CO₂ Controller:** Marked % CO₂, this controller contains the digital CO₂ display, UP and DOWN arrow pads, HIGH and LOW alarm indicators, and alarm MUTE indicator.
- Digital CO₂ Display** indicates the % CO₂ content within the incubator chamber to .1%.
 - UP and DOWN Arrow Pads** are used for inputting the set point, calibrating the display and muting or unmuting the audible alarm.
 - HIGH and LOW Alarm Indicators** will light whenever there is an alarm condition associated with the CO₂% within the incubator chamber.
 - Alarm Mute Indicator** will light whenever the audible alarm has been muted.
- 4.8 Injection:** This pilot lamp is on whenever the CO₂ controller is injecting CO₂ into the incubator chamber. Note that there is a rocker switch located at the base of the control panel and just above the door. The door, when opened, trips the switch and disengages injection of CO₂. This is an added feature that saves consumption of gas while loading/unloading the chamber.

Figure 2

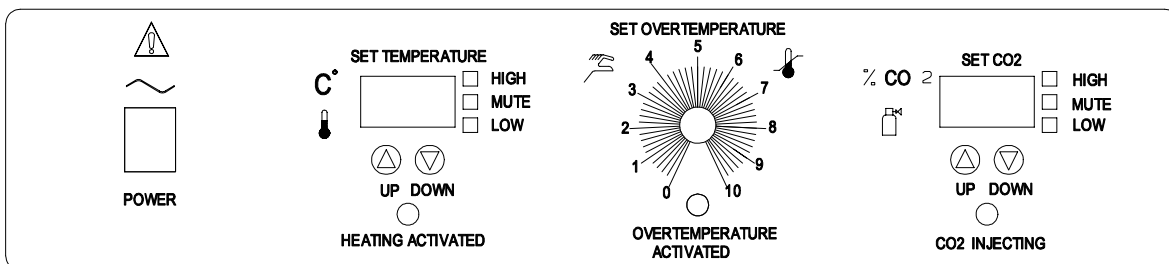

OPERATION

Read this section in its entirety before attempting operation.

Connect service cord to grounded outlet. Set temperatures before connecting CO₂ supply to the incubator.

CAUTION: HUMIDIFICATION OF THIS UNIT POSES A SHOCK HAZARD DUE TO NON VAPOR PROOF EXTERIOR OUTLETS. USE OUTLETS WITH CAUTION.

- 5.1 Getting Started:** Turn the High Limit Thermostat to its maximum position, clockwise. An accurate reference thermometer should be used inside the chamber when setting and calibrating the incubator temperature. Be certain that the thermometer can be easily viewed through the glass door and is not touching any shelves or chamber walls as this will give an inaccurate reading. Taping the thermometer to a petri dish is a method that works well for this.
- 5.2 Setting Main Temperature Controller:** Enter desired set point. To set temperature on the control press either the UP or DOWN arrow pad until the digital display begins to blink from bright to dim. While blinking the display is showing the current set point which can be changed by pushing the UP and DOWN arrow pads until the desired value is reached. If no adjustments are made within five (5) seconds, the controller will default back to displaying the temperature within the chamber. Once set point is established allow 24 hours for the temperature to stabilize.
- 5.3 Calibrating Main Temperature Controller:** During Main Temperature Calibration it is important that the door not be opened for any reason, and the temperature has been stable at set point for several hours. Compare the reference thermometer with the digital display. If there is an unacceptable difference put the display into calibrate mode by pressing both the UP and DOWN arrow pads at the same time until the two outside decimal points begin to flash. While the decimal points are flashing the display can be changed to match the reference thermometer by pushing the UP or DOWN arrow pads. If no adjustments are made within five (5) seconds the display will default back to displaying the temperature in the chamber. After the display has restabilized and maintained set point for several hours, check the actual temperature again. If the reference thermometer does not match the display, repeat the calibration.
- 5.4 Setting High Limit Thermostat:** With the Main control calibrated and stable at

set point, the High Limit needs to be adjusted. Previously turned to its maximum position as stated in section 5.1, now turn the control knob counterclockwise just until the SAFETY ACTIVATED indicator light comes on. Next, turn the control knob clockwise just until the indicator light goes off. Then turn the control knob clockwise two (2) of the smallest divisions on its scale past the point where the indicator light went off. This should adjust the High Limit set point to approximately 1°C above the Main Temperature Control set point. It is recommended that the High Limit set point be checked periodically to assure no changes have occurred. A mark on the dial will aid for future reference if changes to this set point occur.

5.5 Temperature Alarms: The Main Temperature Control has visual/audible alarm indicators for HIGH and LOW conditions that are activated whenever the actual temperature is 1°C above or below the set point. There is a built in delay of fifteen (15) minutes on the occurrence of the audible LOW alarm. This prevents the alarm from activating every time the door is opened and the temperature drops.

5.6 Muting Audible Alarm: The audible alarm can be muted for a single alarm occurrence by pressing and holding down either the UP or DOWN arrow pad for several seconds until the alarm is muted and the MUTE indicator comes on. This means the alarm is muted for that particular condition while it exists, but is not muted indefinitely or for a separate condition that may occur.

5.7 CO₂ Supply: As stated at the beginning of this section, do not connect the CO₂ supply to the incubator until the temperatures have been set. Use only MEDICAL GRADE CO₂ with an in-line filter (provided with your tubing kit) from the tank to the incubator. These incubators use CO₂ in small quantities. Precise metering of input is vital for maximum performance and only a two-stage CO₂ pressure regulator is recommended. Note that some single-stage CO₂ pressure regulators have two (2) gauges, be certain you are using only a two-stage regulator.

5.8 CO₂ Regulator: The high-pressure stage of the regulator coming direct from the supply tank must have a range from 0 to at least 2000 PSI (actual tank pressure as read on the gauge). The low-pressure stage should have a range from 0 to at least 40 PSI. The low-pressure gauge indicates actual CO₂ pressure into the incubator. Connect the CO₂ supply from the low-pressure stage of the regulator to the 3/8" inlet fitting on the left side of the unit marked CO₂ TO CHAMBER.

CAUTION: CO₂ pressure to the incubator inlet is rated from 5 to 40 PSI. DO NOT exceed 40 PSI.

5.9 CO₂ Principle of Operation: The microprocessor CO₂ control system interprets the information from the CO₂ sensor, displays the CO₂ concentration directly on the digital display, reads the set point and controls the percentage of CO₂ in the incubator chamber. The infrared (IR) sensor operates under the principle that a certain frequency of infrared light is absorbed by CO₂. The more CO₂ present in the chamber the more light is absorbed. The IR sensor is only sensitive to CO₂, so its accuracy is consistent no matter what the conditions are in the incubator.

5.10 Setting CO₂ Controller: To set the CO₂ percent you desire press either the UP or DOWN arrow pad until the digital display begins to blink from bright to dim. While blinking, the display is showing the current set point which can be changed by pushing the UP and DOWN arrow pads until the desired value is reached. If no adjustments are made within five (5) seconds, the controller will default back to displaying the parameter within the chamber. Once set point is established allow several hours for CO₂ to stabilize.

5.11 Calibrating CO₂ Controller: During CO₂ calibration it is important that the door not be opened for any reason and the CO₂ has been stable for several hours. Using a Fyrite gas analyzer, measure the actual CO₂% within the chamber via the sample port on the left side of the unit. (For Fyrite reading instructions see section 6.0.) If there is an unacceptable difference between the display and the Fyrite put the display into calibration mode by pressing both the UP and DOWN arrow pads at the same time until the decimal points begin to flash. While the decimal points are flashing the display can be changed to match the Fyrite by pushing the UP or DOWN arrow pads. If no adjustments are made within five (5) seconds the display will default back to displaying the CO₂% in the chamber. After the display has restabilized and maintained set point for several hours, check the actual CO₂% again. If the Fyrite does not match the display, repeat the calibration.

NOTE: When using the Fyrite, insure that gas is not being injected while the reading is being taken. Change the CO₂ set point to 0.0 prior to taking the sample and change the set point back to the desired value after the use of the Fyrite is finished.

5.12 It is recommended that the accuracy of your CO₂ control system be monitored by measuring the actual CO₂ concentration on a weekly basis with a Fyrite or other measuring device. This should be done when the chamber has not been disturbed for an extended period of time i.e. after the weekend, or first thing on Monday morning.

5.13 CO₂ Alarms: The CO₂ controller has visual/audible alarm indicators for HIGH and LOW conditions that are activated whenever the actual CO₂ content is 1% above or below the set point. There is a built in delay of fifteen (15) minutes on the occurrence of the LOW audible alarm. This prevents the alarm from activating every time the door is opened and the CO₂ content drops. See Section 5.6 for MUTING the audible alarm.

5.14 Accessory Outlets: There are four (4) outlets inside the chamber for use with equipment not exceeding 1 amp. Note that equipment in the chamber may provide additional heat that could affect the temperature range of the incubator. It is recommended that testing be done with the incubator and any additional equipment to insure that the desired operating conditions can be met.

CAUTION: this incubator is capable of safely operating at conditions that might otherwise damage certain accessory equipment. Make absolutely certain your accessory equipment is capable of operating under the conditions you intend to run your incubator.

FYRITE READING

NOTE: Be sure to hold canister away from face. Do not press button with canister inverted. To ensure accuracy, it is important to always follow the same procedure when taking a Fyrite reading.

1. Press button on top of Fyrite canister to release CO₂ concentration. Tip canister to the side to ensure all fluid is released from top of canister.
2. Loosen screw on slide scale and align top of fluid with zero on the scale. Tighten screw.
3. Connect hose and bulb to unit being tested.
4. Place hose directly over button on top of canister and press firmly.
5. With button depressed, squeeze bulb 27 times. On the last squeeze and with bulb still deflated, release hose from button.
6. Turn Fyrite canister upside down 3 times, each time allowing all fluid to flow to the opposite end of the canister.
7. Tip canister slightly to ensure all fluid has been released from top of canister.
8. Read CO₂ concentration in %.

NOTE: Your Fyrite indicator will come with a complete set of detailed instructions which should be followed carefully. The fluid used inside this Fyrite instrument is poisonous and corrosive and must not be taken internally. In event of a spill or accidental body contact with the Fyrite fluid, follow instructions on the refill bottle carefully.

MAINTENANCE

NOTE: Prior to any maintenance or service on this unit, disconnect the service cord from the power supply.

- 7.1 Cleaning:** Cleaning and decontamination are recommended on a regular basis. To prepare the incubator for cleaning remove all interior parts such as shelves and shelf clips.

First clean the chamber with soap and water, rinse and let dry. To decontaminate use a solution that is appropriate to your application. DO NOT USE chlorine-based-bleaches or abrasives as this can damage the interior chamber. DO NOT USE spray cleaners that might leak through openings and cracks and get on electrical parts or that may contain solvents that will harm coatings.

WARNING: Never clean the unit with alcohol or flammable cleaners with the unit connected to the electrical supply. Always disconnect the unit from the electrical service when cleaning and assure all volatile or flammable cleaners are evaporated and dry before reattaching the unit to the power supply.

- 7.2** Check CO₂ supply periodically; do not let it run out. (Automatic tank switches are available from your dealer.)
- 7.3** Periodically check CO₂ supply lines and connections for leaks. Use a liquid soap solution to detect leaks. Wet supply line and connections and look for bubbles.
- 7.4** Keep the CO₂ flow system free of impurities. Erratic CO₂ control is usually traceable to the CO₂ pressure regulator on the tank, impurities in the tank, or impurities in the solenoid valve. Replace the CO₂ in-line filter annually or when the filter has become noticeably dirty on the upstream side.
- 7.5** There is no maintenance required on electrical components. If the unit fails to operate as specified, see Section 8.0 Troubleshooting before calling for service. If technical assistance is required, see the manual cover for information on where to reach customer service.

TROUBLESHOOTING

The incubator is designed so that no internal electrical servicing should be required under normal conditions. If electrical servicing is necessary, it should be performed by qualified service personnel. FOR PERSONAL SAFETY, ALWAYS DISCONNECT THE POWER BEFORE SERVICING.

Always make a visual inspection of the incubator and control console when troubleshooting. Look for loose or disconnected wires or tubing, which may be the source of the trouble.

TEMPERATURE

Temperature too high

- 1/ controller set too high-see section 5.2
- 2/ controller failed on – call Customer Service
- 3/ wiring error – call Customer Service

Display reads "HI" or "400"+

- probe is unplugged, is broken or wire to sensor is broken – trace wire from display to probe; move wire and watch display to see intermittent problems

Chamber temp spikes over set point and then settles to set point

- recalibrate – see section 5.3

Temperature too low

- 1/ high limit set too low – see section 5.4
- 2/ controller set too low – see section 5.2
- 3/ unit not recovered from door opening – wait for display to stop changing
- 4/ unit not recovered from power failure or being turned off – incubators will need 24 hours to warm up and stabilize
- 5/ element failure – see if heating light is on; compare current draw to data plate
- 6/ controller failure – confirm with front panel lights that controller is calling for heat
- 7/ high limit failure – confirm with front panel lights that it is operating correctly
- 8/ wiring problem – check all functions and compare wiring to diagram in section 9.0, especially around any areas recently worked on
- 9/ loose connection – check shadow box for loose connections

Display reads "LO"

- 1/ sensor is plugged in backwards – reverse sensor wires to controller
- 2/ if ambient room temperature is lower than range of unit – compare set points and ambient temperature to rated

specifications in section 9.0

Unit will not heat over a temperature that is below set point

- 1/ confirm that fan is moving and that amperage and voltage match data plate – check fan motor motion in shadow box and feel for air movement in chamber
- 2/ confirm that set point is set high enough –turn High Limit counter clockwise and see if heating light or safety light comes on.
- 3/ check connections to sensors
- 4/ check calibration – using independent certified reference thermometer, follow instructions in sections 5.1 and 5.3

Unit will not heat up at all

- 1/ verify that controller is asking for heat by looking for controller light – if pilot light is not on continuously, there is a problem with the controller
- 2/check amperage – amperage should be virtually at maximum rated (data plate) amperage
- 3/ do all controller functions work?
- 4/ is the High Limit set high enough? – for diagnostics, should be fully clockwise with the pilot light never on
- 5/ has the fuse/circuit breaker blown?

Indicated chamber temperature unstable

- 1/ ± 0.1 may be normal
- 2/ is fan working? – remove top panel and verify movement of cooling fan in center of shadow box
- 3/ is ambient room temperature radically changing – either door opening or room airflow from heaters or air conditioning ? – stabilize ambient conditions
- 4/ sensor miss-located, damaged or wires may be damaged - check mounts for control and High Limit sensors, then trace wires between sensors and controls
- 5/ calibration sensitivity – call Customer Service
- 6/ high limit set too low – be sure that High Limit set point is more than 5 degrees over desired Main set point; check if High Limit pilot is on continuously; turn controller knob completely clockwise to see if problem solved then follow instructions in section 5.4 for correct setting.
- 7/ electrical noise – remove nearby sources of RFI including motors, arcing relays or radio transmitters
- 8/ bad connection on temperature sensor or faulty sensor – check connectors for continuity and mechanical soundness while watching display for erratic behavior; check sensor and wiring for mechanical damage
- 9/ bad connections or faulty solid state relay – check connectors for mechanical soundness and look for corrosion around terminals or signs of arcing or other visible deterioration

Will not maintain set point

- 1/ assure that set point is at least 5 degrees over ambient room temperature
- 2/ see if ambient is fluctuating

Display and reference thermometer don't match

- 1/ calibration error – see section 5.3
- 2/ temperature sensor failure – evaluate if pilot light is operating correctly

- 3/ controller failure – evaluate if pilot light is operating correctly
- 4/ allow at least two hours to stabilize
- 5/ verify that reference thermometer is certified

Can't adjust set points or calibration

- 1/ turn entire unit off and on to reset
- 2/ if repeatedly happens, call Customer Service

Calibrated at one temperature, but not at another

This can be a normal condition when operating temperature varies widely. For maximum accuracy, calibration should be done at or as close to the set point temperature.

CO2 LEVEL

Overshoots set point but stabilizes - display and Fyrite match

- 1/ turn set point up and down to see if solenoid valve works by feeling and listening to valve
- 2/ recalibrate with Fyrite, see section 5.11 and section 6.0
- 3/ fan not operating correctly
 - a- fan motor stopped
 - b- fan blade fell off
 - c- wrong fan blade installed or mounted backwards
- 4/ wrong restrictor installed or missing altogether
- 5/ tank pressure too high, see section 5.8
- 6/ CO2 sensor partially plugged with dirt or condensation
- 7/ regulator set wrong, see section 5.8
- 8/ incubator too heavily loaded
- 9/ incubator being operated without shelving
- 10/ CO2 attached to sample port instead of "CO2 IN" fitting
- 11/ If display and Fyrite does not match, see below

Overshoots set point and continues to rise - display and Fyrite match

- 1/ debris in solenoid causing it to leak continuously
- 2/ solenoid failed while open
- 3/ unit miss-wired
- 4/ controller output failed or shorted
- 5/ CO2 sensor or interface failure
- 6/ CO2 sensor plugged by debris or condensation

Rises very slowly

- 1/ restrictor partially plugged
- 2/ filter overly dirty or partially plugged
- 3/ CO2 tank regulator set too low, see section 5.8
- 4/ hose kinked or leaking
- 5/ poor door seal
- 6/ CO2 tank contains mixed gas, not 100% medical grade CO2

Never rises

- 1/ CO2 tank empty
- 2/ solenoid failed while closed
- 3/ CO2 controller output failed while open
- 4/ restrictor plugged
- 5/ CO2 hose blockage
- 6/ CO2 filter plugged
- 7/ set point is at 0.0 and has not been reset, see section 5.10 and 5.11

Display and Fyrite reading do not match

- 1/ calibration error - clear chamber for 12 hrs and confirm at "0"
- 2/ turn set point up and down to see if solenoid valve works by feeling and listening to valve
- 3/ assure that IR tube block is completely tight
- 4/ if display is varying when doing Fyrite test, have a leak on IR base or mounting plate, or CO2 is injecting at time of test.
- 5/ take voltage reading across sensor leads 0=0V and 20=1V
- 6/ assure that sensor is properly mounted
- 7/ disp lower than fyrite: air leak around the CO2 sensor or fan motor shaft
- 8/ display higher than fyrite: leak in tube from sample port to chamber
- 9/ display higher than fyrite: Fyrite fluid worn out, replace fluid with Fyrite refill.
- 10/ display higher than fyrite: poor Fyrite sampling technique, see section 6.0
- 11/ display higher than fyrite: defective Fyrite pump or tubing
- 12/ CO2 sensor, interface or controller failure

Is unstable – display or actual reading varies around set point

- 1/ confirm that fan is working
- 2/ check for air leak around CO2 sensor or fan motor shaft
- 3/ magnetic field interference
- 4/ poor door seal
- 5/ atmospheric pressure fluctuations
- 6/ defective Fyrite pump or tubing
- 7/ CO2 entering chamber too quickly
 - a- tank pressure too high
 - b- regulator set wrong
 - c- restrictor incorrect or missing
- 8/ electronic problem with CO2 sensor, interface or controller
- 9/ top of unit exposed to cold air drafts
- 10/ unit being operated without shadow box cover
- 11/ electrical interference – atmospheric or conducted
- 12/ incubator too heavily loaded

Can't adjust set points or calibration - "locked up"

- 1/ turn unit off, then on to reset processor in controller
- 2/ if repeatedly happens, call Customer Service

Feeding continuously or abnormally high CO2 usage

- 1/ do decay test: if more than 1% decay in an hour, check for leak : door gasket tightness, motor inlet to chamber, sensor and probe inlet to chamber
- 2/ check output signal from controller
- 3/ check solenoid valve for correct operation
- 4/ leak in plumbing including between regulator and CO2 tank
- 5/ door being opened too often

Won't hold calibration – Fyrite reading varies but display stable

- 1/ atmospheric pressure fluctuations
- 2/ top of unit exposed to cold air drafts
- 3/ unit being operated without shadow box cover in place

- 4/ condensation collecting on CO2 sensor
- 5/ CO2 sensor or interface failure
- 6/ unit incorrectly calibrated, see section 5.11
- 8/ taking Fyrite reading too soon after the door has been opened
- 9/ air leak around CO2 sensor mounting plate

MECHANICAL

Door not sealing

- 1/ check physical condition of gasket
- 2/ confirm that door latch pulls door in tightly
- 3/ assure that gasket is in original location

Motor doesn't move

- 1/ if shaft spins freely: check connections to motor and check voltage to motor;
- 2/ if shaft rubs or is frozen, relieve binding and retest

Motor makes noise

- 1/ If noise is from the motor, tap the top of motor shaft with ball peen hammer.
- 2/ If the sound gets worse, tap the other end of the shaft - avoiding touching the fan blade.
- 3/ If there is no change, call Customer Service.
- 4/ If noise is from shaft or fan blade, realign shaft.

Solenoid valve buzzing

After removing solenoid clean with alcohol for carbon build-up then blow out. Check valve seat or channels for contamination. Check CO2 filter and/or grade of CO2 used. If seat is worn, replace.

OTHER

Controller on at all times - "locked-up"

- 1/ Adjust set point to room temperature. If the light goes out but is still heating, replace the solid state relay.
- 2/ turn unit off and on to reset
- 3/ if cannot change any condition on the front panel, call Customer Service

Front panel displays are all off

- 1/ Check for wire damage.

unit or wall fuse/circuit breaker is blown

- 1/ check wall power source
- 2/ compare current draw and compare to specs on data plate
- 3/ see what other loads are on the wall circuit

unit will not turn on

- 1/ check wall power source
- 2/ check fuse/circuit breaker on unit or in wall
- 3/ see if unit is on, e.g., fan or heater, and just controller is off
- 4/ check all wiring connections, esp. around the on/off switch

Unit is smoking – Out of box

Put unit under vent and run at full power for one hour.

Contamination in chamber

- 1/ see cleaning procedure in operator's manual
- 2/ develop and follow Standard operating procedure for specific application; include definition of cleaning technique and maintenance schedule.

Contamination in sample

1/ see "Contamination in chamber"

2/ reduce air flow in chamber by dampening down inlet restrictor; be sure to verify adequate temperature uniformity at the reduced air flow

3/ protect open samples from areas of maximum air current, e.g., inlet air ducts

PARTS LIST

Description	115V	220V
Blower Motor	4880504	4880504
CO ₂ Control	1750559	1750560
CO ₂ Sensor	8320501	8320501
CO ₂ Solenoid	8600528	8600529
Convenience Outlet - Chamber	100020	101483
Door Switch	X1000022	X1000022
Heating Element-1917	9570713	9570845
Heating Element-1927	9570715	9570716
High Limit Thermostat	10000J	10000J
I/O Switch	103351	103351
Pilot Light, Green	200021	200021
Pilot Light, Red	200020	200020
Power Cord	1800516	101990
Temperature Control	1750557	1750558
Transformer 120VAC/12VDC	6750507	6750507
Transformer, Stepdown 220-115V	NA	103107

UNIT SPECIFICATION

Weight	Shipping	Net
1917	660 lbs	610 lbs.
1927	850 lbs.	710 lbs.

Dimensions	Exterior WxDxH (in.)	Interior WxDxH (in.)
1917	36 x34 x 74	31 x 25 x 62
1927	41 x 34 x 87	35 x 26 x 76.5

Capacity	Cubic Feet
1917	28
1927	40

Temperature	Range	Uniformity	Sensitivity
1917	Amb. +.5 to 70°C	$\pm .5^{\circ}\text{C} @ 37^{\circ}$	$\pm .05^{\circ}\text{C}$
1927	Amb. +.5 to 70°C	$\pm .5^{\circ}\text{C} @ 37^{\circ}$	$\pm .05^{\circ}\text{C}$

PLUMBING DIAGRAM

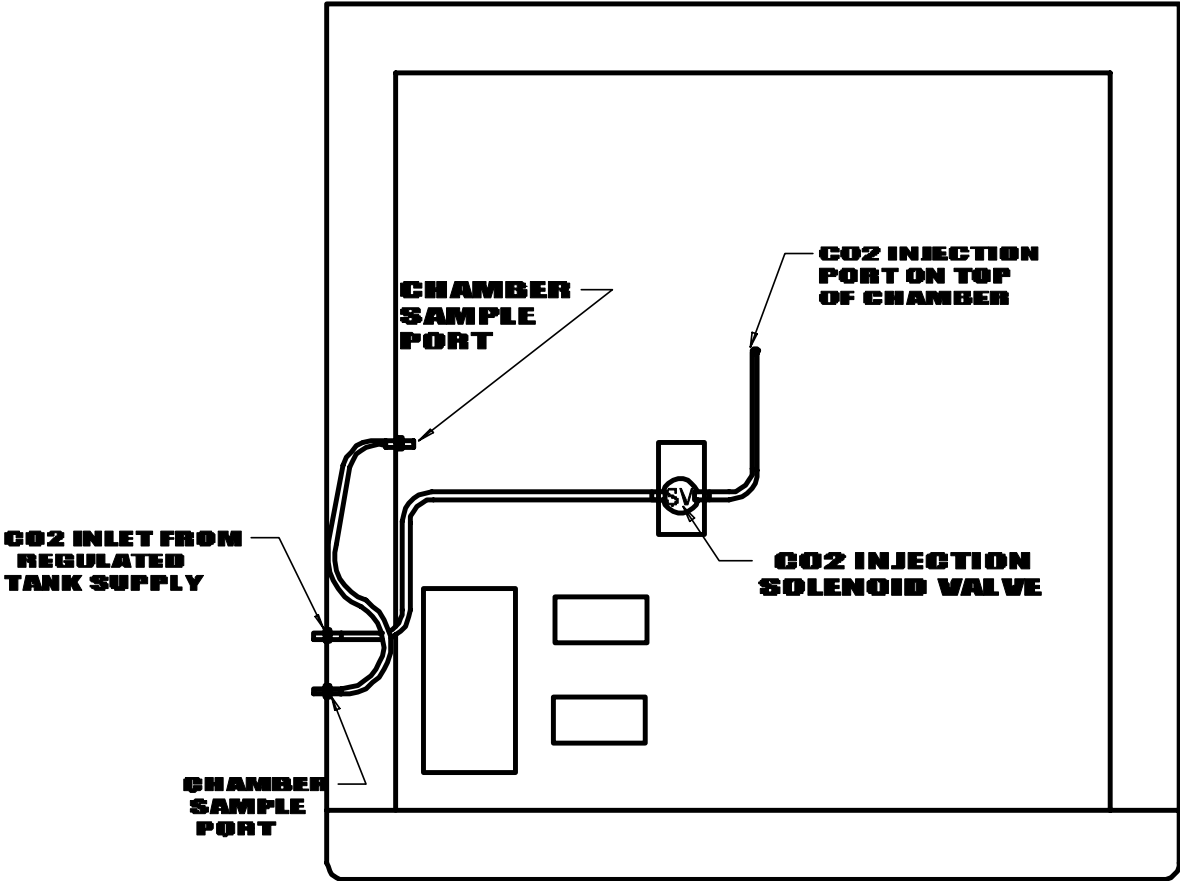

9850863

WIRE DIAGRAM

DOMESTIC MODELS

"CE" MODELS

